

| CIRCUIT SIZE | DIM. "A" | DIM. "B" | DIM. "C" | DIM. "D" | DIM. "E" |
|--------------|------------------|----------------|------------------|------------------|----------------|
| 2 | .520 (13.20) | — | .425 (10.80) | .370 (9.40) | .21 (5.4) |
| 4 | .685 (17.40) | .17 (4.2) | .590 (15.00) | .535 (13.60) | .38 (9.6) |
| 6 | .850 (21.60) | .33 (8.4) | .756 (19.20) | .701 (17.80) | .54 (13.8) |
| 8 | 1.016 (25.80) | .50 (12.6) | .921 (23.40) | .866 (22.00) | .71 (18.0) |
| 10 | 1.181 (30.00) | .66 (16.8) | 1.087 (27.60) | 1.031 (26.20) | .87 (22.2) |
| 12 | 1.346 (34.20) | .83 (21.0) | 1.252 (31.80) | 1.197 (30.40) | 1.04 (26.4) |
| 14 | 1.512 (38.40) | .99 (25.2) | 1.417 (36.00) | 1.362 (34.60) | 1.20 (30.6) |
| 16 | 1.677 (42.60) | 1.16 (29.4) | 1.583 (40.20) | 1.528 (38.80) | 1.37 (34.8) |
| 18 | 1.843 (46.80) | 1.32 (33.6) | 1.748 (44.40) | 1.693 (43.00) | 1.54 (39.0) |
| 20 | 2.008 (51.00) | 1.49 (37.8) | 1.913 (48.60) | 1.858 (47.20) | 1.70 (43.2) |
| 22 | 2.173 (55.20) | 1.65 (42.0) | 2.079 (52.80) | 2.024 (51.40) | 1.87 (47.4) |
| 24 | 2.339 (59.40) | 1.82 (46.2) | 2.244 (57.00) | 2.189 (55.60) | 2.03 (51.6) |

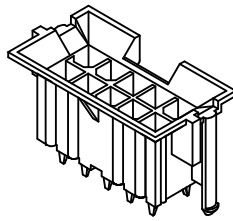

- NOTES:
- MATERIAL:
HOUSING MATERIAL:
A=NYLON 6/6, UNFILLED UL94 V-2, COLOR: NATURAL
B=NYLON 6/6, UNFILLED UL94 V-0, COLOR: NATURAL
TERMINALS: BRASS
 - TERMINAL PLATING:
A=.000100/(0.00254) MIN. MATTE TIN OVER .000050/(0.00127) MIN. NICKEL
D=.000100/(0.00254) MIN. BRIGHT TIN OVER .000050/(0.00127) MIN. NICKEL
E=.000030/(0.00076) MIN. SELECT GOLD AND .000100/(0.00254) MIN. SELECT MATTE TIN OVER .000050/(0.00127) MIN. NICKEL OVERALL
 - PRODUCT SPECIFICATION: PS-5556-002
 - PACKAGING: TRAY PACK PER PK-42440-001
 - PART MATES WITH MINI-FIT RECEPTACLES 5557, 42474,44516 AND BMI HEADER 42385.
 - PART ALLOWS FOR UP TO .100/(2.54) MISALIGNMENT WITH MATING RECEPTACLE IN ANY DIRECTION. SEE MATING CONNECTOR DRAWINGS FOR SPECIFIC ALLOWANCES.
 - THIS PART IS NOT DESIGNED FOR CURRENT SHARING.
 - CONNECTOR ASSEMBLIES ARE NOT TO BE MATED OR UNMATED WHILE CIRCUITS ARE LIVE.
 - RIB LOCATION IS DETERMINED BY MOLD DESIGN FOR MANUFACTURING EASE AND THE LOCATION DOES NOT AFFECT PART FUNCTION OR PERFORMANCE. LOCATION OF RIBS MAY VARY ON PARTS WITHIN MANUFACTURING LOT OR SHIPMENT. THIS DRAWING SHOWS TYPICAL RIB LOCATIONS.
 - PART CONFORMS TO CLASS "B" REQUIREMENTS OF COSMETIC SPECIFICATION PS-45499-002.

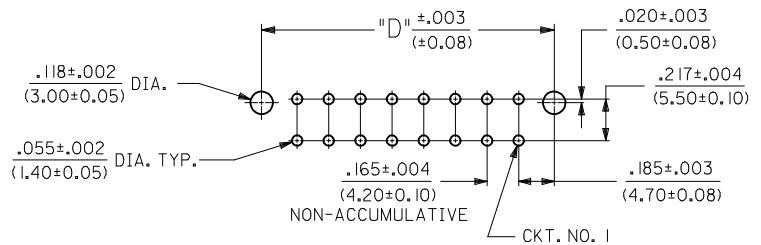
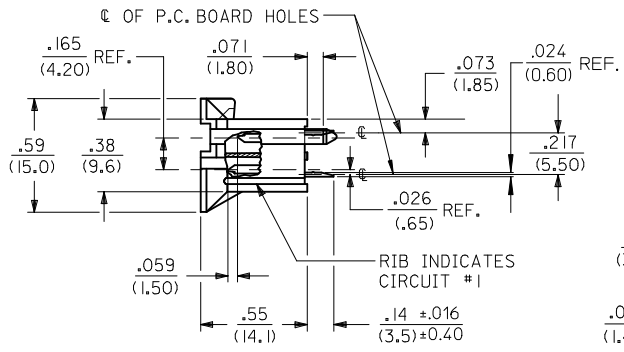
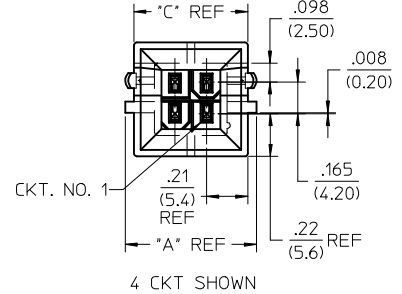

RECOMMENDED HOLE LAYOUT FOR .070/(1.78) MAX. THICK P.C. BOARD

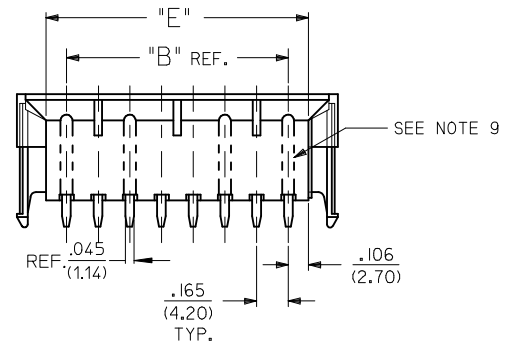
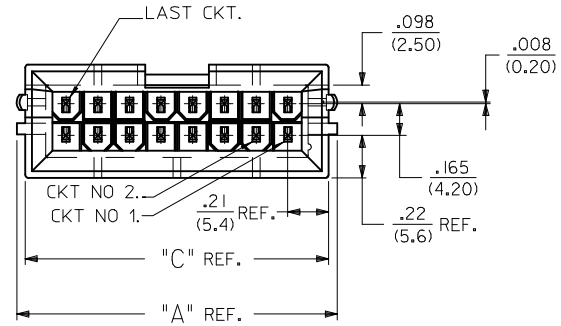

| | | | | | | | | | | |
|---|--|--------------------|--------------------------------------|---------------------------------------|------|--------------------------|--------------------|---|--------------------------------|------------------------|
| ADD 43459-0055 EC NO: UCP2015-1722 DRWN: DFOX CHKD: JBEL APPR: FSMITH | 2014/10/23 2014/10/23 2014/10/27 | DESCRIPTION REV | QUALITY SYMBOLS ▽=0 ▽=0 ▽=0 | GENERAL TOLERANCES (UNLESS SPECIFIED) | | DIMENSION STYLE IN/MM | | SCALE 2:1 | DESIGN UNITS METRIC | THIRD ANGLE PROJECTION |
| | | | | mm | INCH | DRAWN BY AFG | DATE 1994/12/07 | TITLE 2-24 CKT. VERT. HEADER MINI-FIT B.M.I. MAKE FIRST/BREAK LAST | DOCUMENT NO. SDA-43459-**** | SHEET NO. 1 OF 3 |
| DRAFT WHERE APPLICABLE MUST REMAIN WITHIN DIMENSIONS | | | | ANGULAR ±1/2° | | SEE CHART | | THIS DRAWING CONTAINS INFORMATION THAT IS PROPRIETARY TO MOLEX INCORPORATED AND SHOULD NOT BE USED WITHOUT WRITTEN PERMISSION | | |

| | | 13 | | 12 | | 11 | | 10 | | 9 | | 8 | | 7 | | 6 | | 5 | | 4 | | 3 | | 2 | | 1 | | | | |
|----------|----------------------------|--|----|----|----|----|----|----|----|----|----|----|----|----|----|----|----|----|----|----|----|----|----|----|----|-------------------------------|-----------|--------------|-----|-------|
| ITEM NO. | CHARACTERISTIC DESCRIPTION | TERMINAL VERSION REQUIRED AT EACH CIRCUIT LOCATION: (SEE CODES AT RIGHT) | | | | | | | | | | | | | | | | | | | | | | | | TERM. CODES FOR CHART AT LEFT | | | | |
| | | 1 | 2 | 3 | 4 | 5 | 6 | 7 | 8 | 9 | 10 | 11 | 12 | 13 | 14 | 15 | 16 | 17 | 18 | 19 | 20 | 21 | 22 | 23 | 24 | TERMINAL NO. | PLATING / | MATERIAL | | |
| J | 43459-0001 | 04AAA | 1 | 1 | 8 | 8 | - | - | - | - | - | - | - | - | - | - | - | - | - | - | - | - | - | - | - | - | - | I=MAKE-FIRST | A | BRASS |
| | 43459-0002 | 04BAA | 1 | 1 | 8 | 8 | - | - | - | - | - | - | - | - | - | - | - | - | - | - | - | - | - | - | - | - | - | ---- | --- | ---- |
| | 43459-0003 | 04AAA | 1 | 1 | 8 | 8 | - | - | - | - | - | - | - | - | - | - | - | - | - | - | - | - | - | - | - | - | - | 3=MAKE-FIRST | E | BRASS |
| | 43459-0004 | 04BAA | 1 | 1 | 8 | 8 | - | - | - | - | - | - | - | - | - | - | - | - | - | - | - | - | - | - | - | - | - | ---- | --- | ---- |
| I | 43459-0005 | 10AAD | 5 | 5 | 5 | 5 | 5 | 5 | 5 | 5 | 5 | 5 | - | - | - | - | - | - | - | - | - | - | - | - | - | - | - | 5=MAKE-FIRST | D | BRASS |
| | 43459-0006 | 10BAD | 5 | 5 | 5 | 5 | 5 | 5 | 5 | 5 | 5 | 5 | - | - | - | - | - | - | - | - | - | - | - | - | - | - | - | ---- | --- | ---- |
| | 43459-0007 | 10AAE | 3 | 3 | 3 | 3 | 3 | 3 | 3 | 3 | 3 | 3 | 3 | - | - | - | - | - | - | - | - | - | - | - | - | - | - | ---- | --- | ---- |
| | 43459-0008 | 10BAE | 3 | 3 | 3 | 3 | 3 | 3 | 3 | 3 | 3 | 3 | 3 | - | - | - | - | - | - | - | - | - | - | - | - | - | - | 8=STANDARD | A | BRASS |
| H | 43459-0009 | 18AAD | 9 | 9 | 9 | 9 | 5 | 5 | 9 | 9 | 9 | 9 | 9 | 9 | 9 | 9 | 9 | 9 | 9 | 9 | - | - | - | - | - | - | - | 9=STANDARD | D | BRASS |
| | 43459-0011 | 24AAD | 5 | 5 | 5 | 5 | 5 | 5 | 5 | 5 | 5 | 5 | 5 | 5 | 5 | 5 | 5 | 5 | 5 | 5 | 5 | 5 | 5 | 5 | 5 | 5 | 5 | 10=STANDARD | E | BRASS |
| | 43459-0012 | 24BAD | 5 | 5 | 5 | 5 | 5 | 5 | 5 | 5 | 5 | 5 | 5 | 5 | 5 | 5 | 5 | 5 | 5 | 5 | 5 | 5 | 5 | 5 | 5 | 5 | 5 | | | |
| | 43459-0013 | 24BAD | 9 | 9 | 9 | 9 | 9 | 9 | 9 | 9 | 9 | 9 | 9 | 9 | 9 | 9 | 9 | 9 | 9 | 9 | 9 | 9 | 9 | 9 | 9 | 9 | 9 | | | |
| G | 43459-0014 | 18BAD | 5 | 5 | 5 | 5 | 5 | 5 | 5 | 5 | 5 | 5 | 5 | 5 | 5 | 5 | 5 | 5 | 5 | 5 | - | - | - | - | - | - | - | | | |
| | 43459-0015 | 18BAE | 3 | 3 | 3 | 3 | 3 | 3 | 3 | 3 | 3 | 3 | 3 | 3 | 3 | 3 | 3 | 3 | 3 | 3 | - | - | - | - | - | - | - | | | |
| | 43459-0016 | 14BAD | 5 | 5 | 5 | 5 | 5 | 5 | 5 | 5 | 5 | 5 | 5 | 5 | 5 | 5 | 5 | 5 | 5 | 5 | - | - | - | - | - | - | - | | | |
| | 43459-0017 | 18BAD | 9 | 9 | 9 | 9 | 5 | 5 | 9 | 9 | 9 | 9 | 9 | 9 | 9 | 9 | 9 | 9 | 9 | 9 | 9 | 9 | 9 | 9 | 9 | 9 | 9 | | | |
| | 43459-0018 | 10AAA | 8 | 8 | 8 | 8 | 8 | 8 | 8 | 8 | 1 | 1 | 1 | - | - | - | - | - | - | - | - | - | - | - | - | - | - | | | |
| F | 43459-0019 | 10BAE | 3 | 3 | 3 | 10 | 10 | 3 | 3 | 3 | 3 | 3 | 3 | - | - | - | - | - | - | - | - | - | - | - | - | - | - | | | |
| | 43459-0020 | 18AAE | 10 | - | 10 | 10 | 10 | 10 | 10 | 10 | 10 | 3 | 3 | 10 | 10 | 10 | 10 | 10 | 10 | 10 | - | - | - | - | - | - | - | | | |
| | 43459-0021 | 10AAD | 5 | 9 | 9 | 9 | 9 | 9 | 9 | 9 | 9 | 9 | - | - | - | - | - | - | - | - | - | - | - | - | - | - | - | | | |
| | 43459-0022 | 10AAD | 5 | 9 | 9 | 9 | 9 | 5 | 9 | 9 | 9 | 9 | - | - | - | - | - | - | - | - | - | - | - | - | - | - | - | | | |
| E | 43459-0023 | 14AAD | 5 | 9 | 9 | 9 | 9 | 9 | 9 | 9 | 9 | 9 | 9 | 9 | 9 | 9 | 9 | 9 | 9 | 9 | - | - | - | - | - | - | - | | | |
| | 43459-0024 | 14AAD | 5 | 9 | 9 | 9 | 9 | 9 | 9 | 9 | 5 | 9 | 9 | 9 | 9 | 9 | 9 | 9 | 9 | 9 | - | - | - | - | - | - | - | | | |
| | 43459-0025 | 18BAE | 10 | 10 | 10 | 10 | 10 | 10 | 10 | 10 | - | 10 | 10 | 10 | 10 | 10 | 10 | 10 | 10 | 10 | 10 | 10 | 10 | 10 | 10 | 10 | 10 | | | |
| | 43459-0026 | 10BAE | 10 | - | 10 | - | 10 | 10 | - | 10 | - | 10 | - | - | - | - | - | - | - | - | - | - | - | - | - | - | - | | | |
| D | 43459-0027 | 24BAE | 10 | 10 | 10 | 10 | 10 | 10 | 10 | 10 | 10 | 10 | 10 | 10 | 10 | 10 | 10 | 10 | 10 | 10 | 10 | 10 | 10 | 10 | 10 | 10 | 10 | | | |
| | 43459-0028 | 24AAE | 3 | 10 | 10 | 10 | 10 | 10 | 10 | 10 | 10 | 10 | 10 | 10 | 3 | 3 | 10 | 10 | 10 | 10 | 10 | 10 | 10 | 10 | 10 | 10 | 3 | | | |
| | 43459-0029 | 14BAE | 10 | 10 | 10 | 10 | 10 | 10 | 10 | 10 | 10 | 10 | 3 | 10 | 10 | 10 | 10 | 10 | 10 | 10 | 10 | 10 | 10 | 10 | 10 | 10 | 10 | | | |
| | 43459-0030 | 04BAE | 3 | 3 | 3 | 3 | - | - | - | - | - | - | - | - | - | - | - | - | - | - | - | - | - | - | - | - | - | | | |
| C | 43459-0031 | 18BAE | 3 | 3 | 3 | 3 | 3 | 3 | 3 | 3 | 3 | 3 | 3 | 3 | 3 | 3 | 3 | 3 | 3 | 3 | 3 | 3 | 3 | 3 | 3 | 3 | 3 | | | |
| | 43459-0032 | 10BAE | 3 | 10 | 10 | 10 | 10 | 3 | 10 | 10 | 10 | 10 | - | - | - | - | - | - | - | - | - | - | - | - | - | - | - | | | |
| | 43459-0033 | 14BAE | 3 | 10 | 10 | 10 | 10 | 10 | 3 | 10 | 10 | 10 | 10 | 10 | 10 | 10 | 10 | 10 | 10 | 10 | 10 | 10 | 10 | 10 | 10 | 10 | 10 | | | |
| | 43459-0034 | 14BAE | 10 | 10 | 10 | 10 | 10 | 10 | 10 | 10 | 10 | 10 | 3 | 10 | 10 | 10 | 10 | 10 | 10 | 10 | 10 | 10 | 10 | 10 | 10 | 10 | 10 | | | |

| TERM. CODES FOR CHART AT LEFT | | |
|-------------------------------|-----------|----------|
| TERMINAL NO. | PLATING / | MATERIAL |
| I=MAKE-FIRST | A | BRASS |
| ---- | --- | ---- |
| 3=MAKE-FIRST | E | BRASS |
| ---- | --- | ---- |
| 5=MAKE-FIRST | D | BRASS |
| ---- | --- | ---- |
| ---- | --- | ---- |
| 8=STANDARD | A | BRASS |
| 9=STANDARD | D | BRASS |
| 10=STANDARD | E | BRASS |

CHARACTERISTICS LEGEND:

CIRCUIT SIZE: _____ ** * *
(02-24)

HOUSING MATERIAL AND OPTIONS: _____

"A"=NYLON 6/6, U.L. 94V-2, COLOR: NATURAL.
"B"=NYLON 6/6, U.L. 94V-0, COLOR: NATURAL.

TERMINAL MATERIAL: _____

"A"=BRASS

TERMINAL PLATING (SEE NOTE 2): _____

"A"=.000100/(0.00254) MIN. MATTE TIN OVER .000050/(0.00127) MIN. NICKEL'
"D"=.000100/(0.00254) MIN. BRIGHT TIN OVER .000050/(0.00127) MIN. NICKEL
"E"=.000030/(0.00076) MIN. SELECT GOLD AND .000100/(0.00254) MIN. SELECT MATTE TIN OVER .000050/(0.00127) MIN. NICKEL OVERALL

| | | | | | | | | | | |
|---|------------|---|--------------------------------------|--|------|---------------------------|--------------------|---|------------------------|------------------------|
| SEE SHEET 1 EC NO: UCP2015-1722 DRWN:JDFX CHKD:JBELL APPR:FSMTH | REV T13 | DESCRIPTION 2014/10/23 2014/10/23 2014/10/27 | QUALITY SYMBOLS ▽=0 ▽=0 ▽=0 | GENERAL TOLERANCES (UNLESS SPECIFIED) | | DIMENSION STYLE IN/MM | | SCALE 1:1 | DESIGN UNITS METRIC | THIRD ANGLE PROJECTION |
| | | | | mm | INCH | DRAWN BY AFG | DATE 1994/12/07 | TITLE 2-24 CKT. VERT. HEADER MINI-FIT B.M.I. MAKE FIRST/BREAK LAST | | |
| | | | | ANGULAR ±1/2° | | MATERIAL NO. SEE CHART | | DOCUMENT NO. SDA-43459-**** | SHEET NO. 2 OF 3 | |
| | | | | DRAFT WHERE APPLICABLE MUST REMAIN WITHIN DIMENSIONS | | SIZE C | | THIS DRAWING CONTAINS INFORMATION THAT IS PROPRIETARY TO MOLEX INCORPORATED AND SHOULD NOT BE USED WITHOUT WRITTEN PERMISSION | | |

| ITEM NO. | CHARACTERISTIC DESCRIPTION | TERMINAL VERSION REQUIRED AT EACH CIRCUIT LOCATION: (SEE CODES AT RIGHT) | | | | | | | | | | | | | | | | | | | | | | | |
|------------|----------------------------|--|----|----|----|----|----|----|----|----|----|----|----|----|----|----|----|----|----|----|----|----|----|----|----|
| | | 1 | 2 | 3 | 4 | 5 | 6 | 7 | 8 | 9 | 10 | 11 | 12 | 13 | 14 | 15 | 16 | 17 | 18 | 19 | 20 | 21 | 22 | 23 | 24 |
| 43459-0035 | 10BAD | 5 | 9 | 9 | 9 | 9 | 5 | 9 | 9 | 9 | 9 | - | - | - | - | - | - | - | - | - | - | - | - | - | - |
| 43459-0036 | 10BAE | 10 | 3 | 10 | 10 | 10 | 10 | 3 | 10 | 10 | 10 | - | - | - | - | - | - | - | - | - | - | - | - | - | - |
| 43459-0037 | 10BAE | 3 | 10 | 10 | 10 | 10 | 10 | 10 | 10 | 10 | 10 | - | - | - | - | - | - | - | - | - | - | - | - | - | - |
| 43459-0038 | 24AAD | 9 | 9 | 9 | 9 | 9 | 9 | 9 | 9 | 9 | 9 | 9 | 5 | 9 | 9 | 9 | 9 | 9 | 9 | 9 | 9 | 9 | 9 | 9 | 9 |
| 43459-0039 | 14BAE | 3 | 10 | 10 | 10 | 10 | 10 | 10 | 3 | 10 | 10 | 10 | 10 | 10 | 10 | - | - | - | - | - | - | - | - | - | - |
| 43459-0040 | 10AAD | 9 | 9 | 9 | 9 | 9 | 5 | 5 | 5 | 5 | 5 | - | - | - | - | - | - | - | - | - | - | - | - | - | - |
| 43459-0041 | 6AAA | 0 | - | - | - | - | - | - | - | - | - | - | - | - | - | - | - | - | - | - | - | - | - | - | - |
| 43459-0042 | 18BAE | 3 | 3 | 3 | 3 | 3 | 3 | 3 | 3 | 3 | 3 | 3 | 3 | 3 | 3 | 3 | 3 | 10 | 10 | - | - | - | - | - | - |
| 43459-0043 | 24AAA | 8 | 8 | 8 | 8 | 8 | 8 | 8 | - | 1 | 1 | - | 8 | 8 | 8 | 8 | 8 | 8 | 8 | 8 | - | 1 | 1 | - | 8 |
| 43459-0044 | 10BAE | 10 | 10 | 10 | 3 | 10 | 10 | 10 | 10 | 10 | 10 | - | - | - | - | - | - | - | - | - | - | - | - | - | - |
| 43459-0045 | 10BAE | 10 | 3 | 3 | 10 | 10 | 3 | 10 | 10 | 10 | 10 | - | - | - | - | - | - | - | - | - | - | - | - | - | - |
| 43459-0046 | 10BAE | 10 | 10 | 10 | 10 | 10 | 10 | 3 | 3 | 3 | 3 | - | - | - | - | - | - | - | - | - | - | - | - | - | - |
| 43459-0047 | 24BAE | 3 | 3 | 3 | 3 | 3 | 3 | 3 | 3 | 3 | 3 | 3 | 3 | 3 | 3 | 3 | 3 | 3 | 3 | 3 | 3 | 3 | 3 | 3 | 3 |
| 43459-0048 | 04BAD | 9 | 5 | 5 | 9 | - | - | - | - | - | - | - | - | - | - | - | - | - | - | - | - | - | - | - | - |
| 43459-0049 | 04BAE | 10 | 3 | 3 | 10 | - | - | - | - | - | - | - | - | - | - | - | - | - | - | - | - | - | - | - | - |
| 43459-0050 | 18BAE | 3 | 3 | 3 | 3 | 3 | 3 | 3 | 3 | 3 | 3 | 10 | 3 | 3 | 3 | 3 | 3 | 3 | 3 | - | - | - | - | - | - |
| 43459-0052 | 24BAD | 9 | - | 9 | - | 9 | - | 9 | - | 9 | - | 9 | - | 9 | - | 9 | - | 9 | - | 9 | - | 9 | - | 9 | - |
| 43459-0053 | 24BAE | 10 | 10 | 10 | 10 | 3 | 3 | 3 | 10 | 10 | 10 | 10 | 10 | 10 | 10 | 10 | 3 | 3 | 3 | 10 | 10 | 10 | 10 | 10 | 10 |
| 43459-0054 | 24BAA | 1 | 1 | 1 | 1 | 1 | 1 | 1 | 1 | 1 | 1 | 1 | 1 | 1 | 1 | 1 | 1 | 1 | 1 | 1 | 1 | 1 | 1 | 1 | 1 |
| 43459-0055 | 14BAA | 8 | 8 | 8 | 1 | 1 | 8 | 8 | 8 | 8 | 8 | 1 | 8 | 8 | 8 | - | - | - | - | - | - | - | - | - | - |

| TERM. CODES FOR CHART AT LEFT | | |
|-------------------------------|-----------|----------|
| TERMINAL NO. | PLATING / | MATERIAL |
| 1=MAKE-FIRST | A | BRASS |
| ---- | --- | ---- |
| 3=MAKE-FIRST | E | BRASS |
| ---- | --- | ---- |
| 5=MAKE-FIRST | D | BRASS |
| ---- | --- | ---- |
| ---- | --- | ---- |
| 8=STANDARD | A | BRASS |
| 9=STANDARD | D | BRASS |
| 10=STANDARD | E | BRASS |

CHARACTERISTICS LEGEND:

CIRCUIT SIZE: _____ ** ** *

(02-24)

HOUSING MATERIAL AND OPTIONS: _____

A=NYLON 6/6, U.L. 94V-2, COLOR: NATURAL.
 B=NYLON 6/6, U.L. 94V-0, COLOR: NATURAL.

TERMINAL MATERIAL: _____

A=BRASS

TERMINAL PLATING (SEE NOTE 2): _____

A=.000100/(0.00254) MIN. MATTE TIN OVER .000050/(0.00127) MIN. NICKEL
 D=.000100/(0.00254) MIN. BRIGHT TIN OVER .000050/(0.00127) MIN. NICKEL
 E=.000030/(0.00076) MIN. SELECT GOLD AND .000100/(0.00254) MIN. SELECT
 MATTE TIN OVER .000050/(0.00127) MIN. NICKEL OVERALL

"0" = OBSOLETE

| | | | | | | | | | | | |
|---|---------------------|---|--------|-----------------|------------|----------------|--------------|--|--|--|--|
| SEE SHEET 1 EC NO: UCP2015-1722 DRWN: JDFX CHKD: JELL APPR: FSMITH 2014/10/23 2014/10/23 2014/10/27 | QUALITY SYMBOLS | GENERAL TOLERANCES (UNLESS SPECIFIED) | | DIMENSION STYLE | | SCALE | DESIGN UNITS | THIRD ANGLE PROJECTION | | | |
| | | | | IN/MM | | 1:1 | METRIC | | | | |
| | | | | mm | INCH | DRAWN BY | DATE | TITLE | | | |
| | | | | 4 PLACES ± .010 | ± .010 | AFG | 1994/12/07 | 2-24 CKT. VERT. HEADER MINI-FIT B.M.I. MAKE FIRST/BREAK LAST | | | |
| | | 3 PLACES ± .010 | ± .010 | CHECKED BY | DATE | | | | | | |
| | | 2 PLACES ± 0.25 | ± .014 | RJF | 1994/12/07 | | | | | | |
| | | 1 PLACE ± 0.36 | ± .014 | APPROVED BY | DATE | DOCUMENT NO. | | | | | |
| | | 0 PLACE ± .010 | ± .010 | FSMITH | 2012/05/22 | SDA-43459-**** | | | | | |
| | | ANGULAR ±1/2° | | MATERIAL NO. | | SHEET NO. | | | | | |
| | | DRAFT WHERE APPLICABLE MUST REMAIN WITHIN DIMENSIONS | | SEE CHART | | 3 OF 3 | | | | | |
| | | THIS DRAWING CONTAINS INFORMATION THAT IS PROPRIETARY TO MOLEX INCORPORATED AND SHOULD NOT BE USED WITHOUT WRITTEN PERMISSION | | | | | | | | | |