



**RO3144E
RO3144E-1
RO3144E-2**

- Ideal for 916.5 MHz FCC Part 15 Transmitters
- Very Low Series Resistance
- Quartz Stability
- Complies with Directive 2002/95/EC (RoHS)



The RO3144E is a true one-port, surface-acoustic-wave (SAW) resonator in a surface-mount ceramic case. It provides reliable, fundamental-mode stabilization of fixed-frequency transmitters operating at 916.5 MHz. This SAW is designed specifically for remote-control and data-link transmitters operating in the USA under FCC Part 15 regulations.

**916.5 MHz
SAW
Resonator**

Absolute Maximum Ratings

Rating	Value	Units
Input Power Level	0	dBm
DC Voltage	12	VDC
Storage Temperature	-40 to +125	°C
Operating Temperature Range	-40 to +125	°C
Soldering Temperature	260	°C

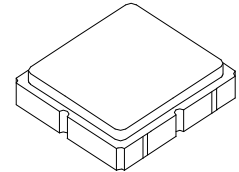

**SM3030-6 Case
3.0 X 3.0**

Electrical Characteristics

Characteristic	Sym	Notes	Minimum	Typical	Maximum	Units
Frequency (+25 °C) Nominal Frequency	RO3144E RO3144E-1 RO3144E-2	f_C	916.300		916.700	MHz
			916.350		916.650	
			916.400		916.600	
Tolerance from 916.5 MHz	RO3144E RO3144E-1 RO3144E-2	Δf_C			±200	kHz
					±150	
					±100	
Insertion Loss	IL	2, 5, 6		1.2	1.6	dB
Quality Factor	Unloaded Q 50 Ω Loaded Q	Q_U		6400		
		Q_L	5, 6, 7		780	
Temperature Stability	Turnover Temperature Turnover Frequency Frequency Temperature Coefficient	T_O	15	25	40	°C
		f_O	6, 7, 8		f_C	MHz
		FTC			0.032	
Frequency Aging	Absolute Value during the First Year	fA	1		10	ppm
DC Insulation Resistance between Any Two Terminals		5	1.0			MΩ
RF Equivalent RLC Model	Motional Resistance Motional Inductance Motional Capacitance Transducer Static Capacitance	R_M			14	Ω
		L_M	5, 6, 7, 9		15.4	μH
		C_M			1.9	fF
		C_O	5, 6, 9		1.9	pF
Test Fixture Shunt Inductance		L_{TEST}	2, 7		16	nH
Lid Symbolization	RO3144E 693, RO3144E-1 769, RO3144E-2 770 / YVWS					
Standard Reel Quantity	Reel Size 7 Inch		10	500 Pieces / Reel		
	Reel Size 13 Inch			3000 Pieces / Reel		



CAUTION: Electrostatic Sensitive Device. Observe precautions for handling.

Notes:

1. Frequency aging is the change in f_C with time and is specified at +65°C or less. Aging may exceed the specification for prolonged temperatures above +65°C. Typically, aging is greatest the first year after manufacture, decreasing in subsequent years.
2. The center frequency, f_C , is measured at the minimum insertion loss point, IL_{MIN} , with the resonator in the 50 Ω test system (VSWR ≤ 1.2:1). The shunt inductance, L_{TEST} , is tuned for parallel resonance with C_O at f_C . Typically, $f_{OSCILLATOR}$ or $f_{TRANSMITTER}$ is approximately equal to the resonator f_C .
3. One or more of the following United States patents apply: 4,454,488 and 4,616,197.
4. Typically, equipment utilizing this device requires emissions testing and government approval, which is the responsibility of the equipment manufacturer.
5. Unless noted otherwise, case temperature $T_C = +25°C ± 2°C$.
6. The design, manufacturing process, and specifications of this device are subject to change without notice.
7. Derived mathematically from one or more of the following directly measured parameters: f_C , IL, 3 dB bandwidth, f_C versus T_C , and C_O .
8. Turnover temperature, T_O , is the temperature of maximum (or turnover) frequency, f_O . The nominal frequency at any case temperature, T_C , may be calculated from: $f = f_O [1 - FTC (T_O - T_C)^2]$. Typically $oscillator T_O$ is approximately equal to the specified *resonator* T_O .
9. This equivalent RLC model approximates resonator performance near the resonant frequency and is provided for reference only. The capacitance C_O is the static (nonmotional) capacitance between the two terminals measured at low frequency (10 MHz) with a capacitance meter. The measurement includes parasitic capacitance with "NC" pads unconnected. Case parasitic capacitance is approximately 0.05 pF. Transducer parallel capacitance can be calculated as: $C_P = C_O - 0.05 pF$.
10. Tape and Reel Standard for ANSI / EIA 481.

Electrical Connections

The SAW resonator is bidirectional and may be installed with either orientation. The two terminals are interchangeable and unnumbered. The callout NC indicates no internal connection. The NC pads assist with mechanical positioning and stability. External grounding of the NC pads is recommended to help reduce parasitic capacitance in the circuit.

Pin	Connection
1	NC
2	Terminal
3	NC
4	NC
5	Terminal
6	NC

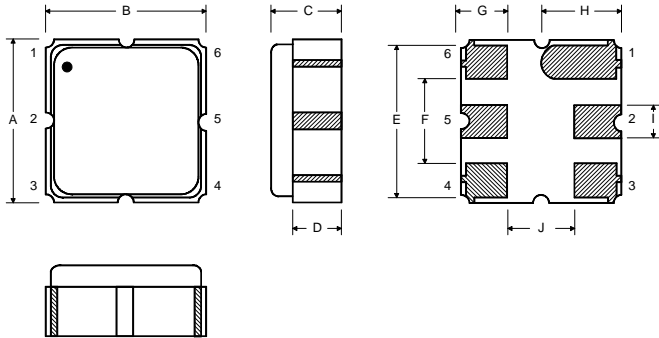

Case Dimensions

Dimension	mm			Inches		
	Min	Nom	Max	Min	Nom	Max
A	2.87	3.0	3.13	0.113	0.118	0.123
B	2.87	3.0	3.13	0.113	0.118	0.123
C	1.12	1.25	1.38	0.044	0.049	0.054
D	0.77	0.90	1.03	0.030	0.035	0.040
E	2.67	2.80	2.93	0.105	0.110	0.115
F	1.47	1.6	1.73	0.058	0.063	0.068
G	0.72	0.85	0.98	0.028	0.033	0.038
H	1.37	1.5	1.63	0.054	0.059	0.064
I	0.47	0.60	0.73	0.019	0.024	0.029
J	1.17	1.30	1.43	0.046	0.051	0.056

Typical Test Circuit

The test circuit inductor, L_{TEST} , is tuned to resonate with the static capacitance, C_O , at F_C .

Electrical Test

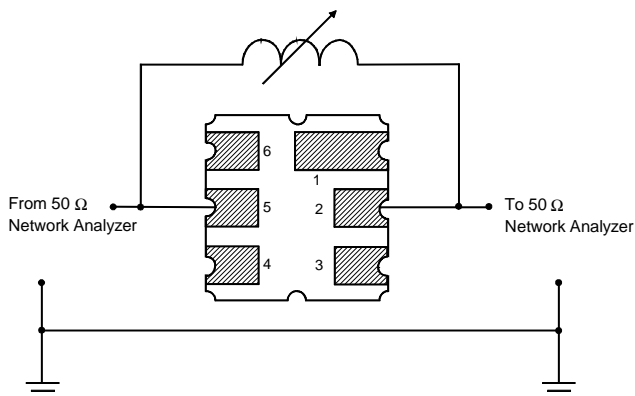

Power Test

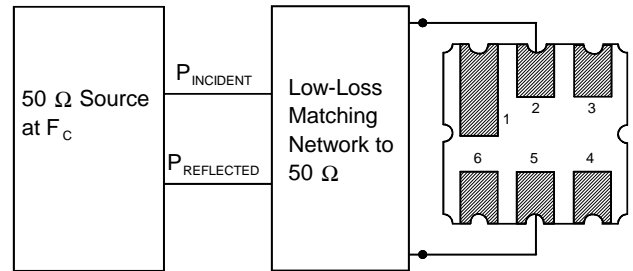

Typical Application Circuits

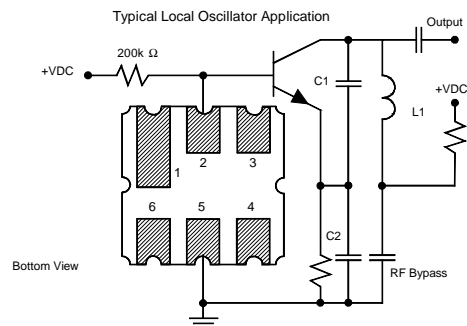
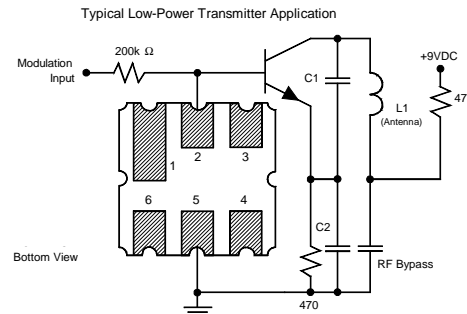

Equivalent LC Model

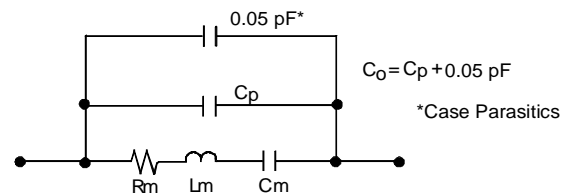

Temperature Characteristics

The curve shown on the right accounts for resonator contribution only and does not include LC component temperature contributions.

