

PRODUCT NUMBER	DESCRIPTION	NOTES
10117771-XXXXLF	NON-HF	SEE SHT. 3
10117771-XXXXHLF	HALOGEN FREE (H)	SEE SHT. 3

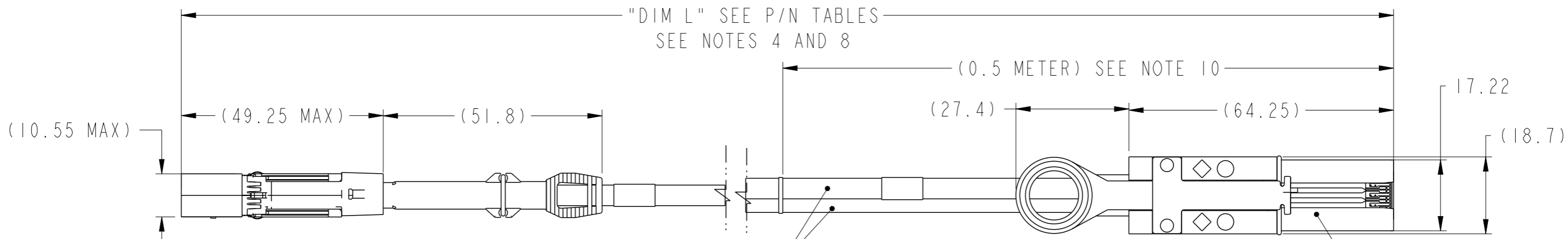

CABLE
SEE TABLE 2 & 3
NOTE 10

END P2
MINI SAS
CABLE CONNECTOR

END P1
MINI SAS HD 4X
CABLE CONNECTOR

HEAT SHRINK
TUBE (2X)

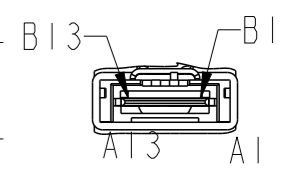

(10.45)
("DIM M")
SEE P/N TABLES

100mm ± 15mm

2X (13.0)

P1 LABEL
SEE NOTE 5

60mm ± 15mm

HEAT SHRINK
TUBE

P2 LABEL
SEE NOTE 5

CABLE TIE COLOR: BLACK
SEE NOTE 10

(25mm)

12.75

SECTION A-A
SCALE 2:1
CABLE ORIENTATION ONLY
MSAS END P2

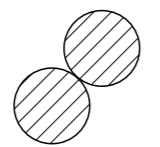

dr	Deborah Ingram	2011/03/17	projection	MM	size	A3	scale	1:1
eng	Deborah Ingram	2012/01/26			ecn no		-	
chr	-	-			rel level		Released	
appr	Brad Brubaker	-	product family	C&A		rev		
			title Mini SAS HD 4X TO Mini SAS 2.1 TRAINED UNIVERSAL FINAL ASSEMBLY (6Gb/s)		dwg no 10117771		rev A	
www.fci.com			cat. no. -		Product - Customer Drw		sheet 1 of 5	



Copyright FCI.

PRODUCT NUMBER	DESCRIPTION	NOTES
10117771-XXXXLF	NON-HF	SEE SHT. 3
10117771-XXXXHLF	HALOGEN FREE (H)	SEE SHT. 3

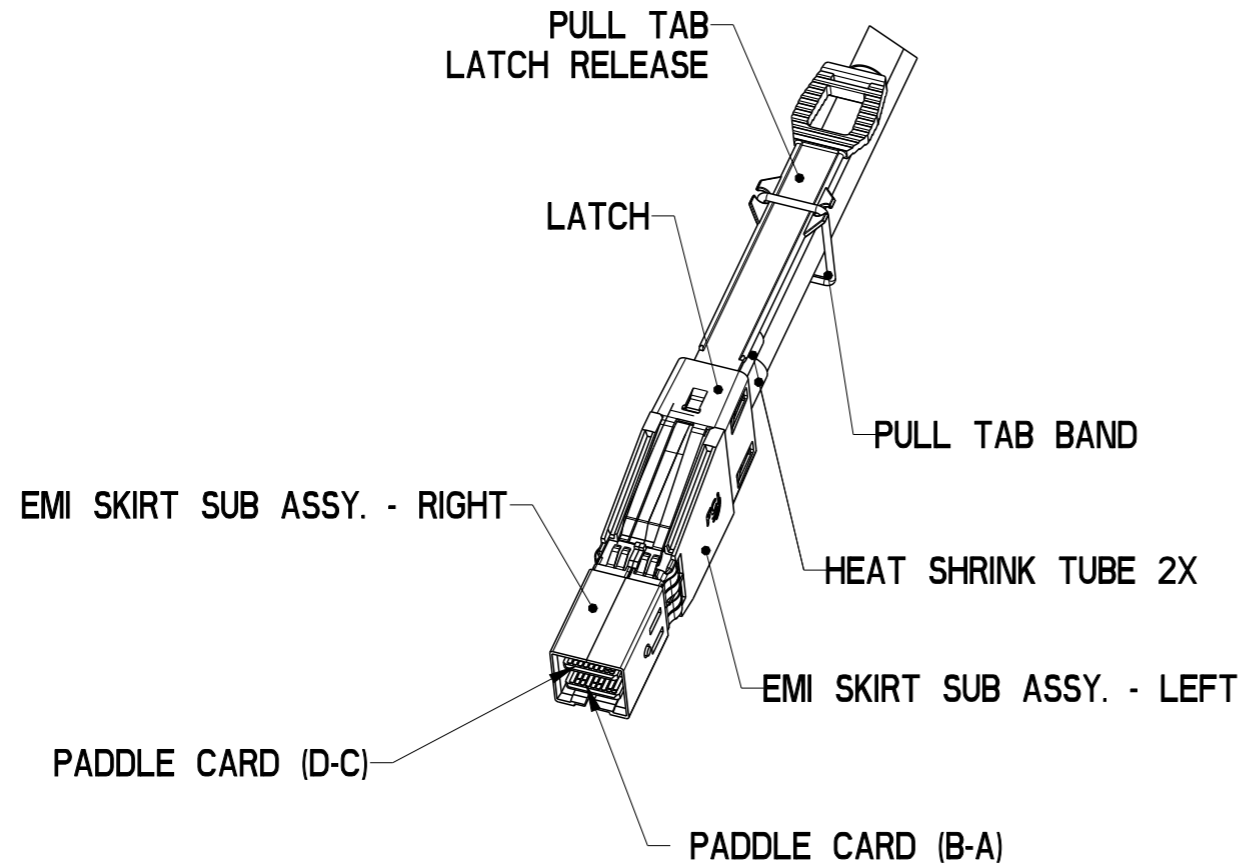

END P1
Mini SAS HD 4X
ISOMETRIC VIEW

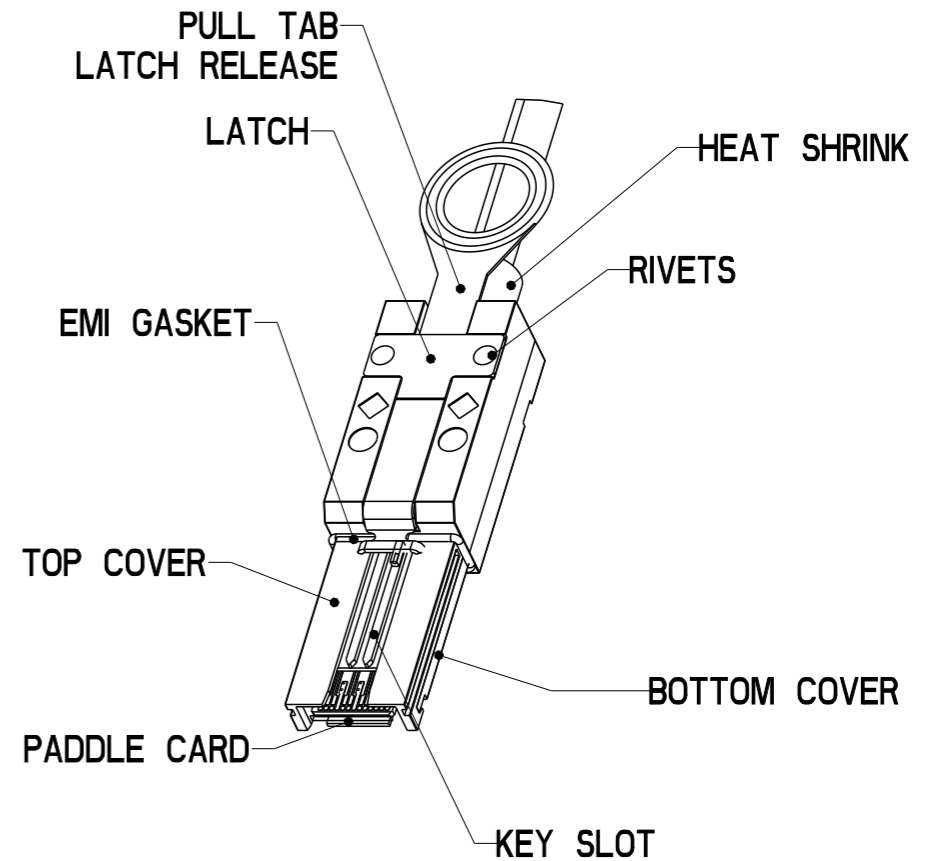



END P2
Mini SAS
ISOMETRIC VIEW

dr	Deborah Ingram	2011/03/17	projection 	MM 	size	A3	scale	1:1
eng	Deborah Ingram	2012/01/26			ecn no	-		
chr	-	-			rel level	Released		
appr	Brad Brubaker	-	product family	C&A				
		title Mini SAS HD 4X TO Mini SAS 2.1 TRAINED UNIVERSAL FINAL ASSEMBLY (6Gb/s)		dwg no 10117771	rev A			
www.fci.com		cat. no.	-		Product - Customer Drw		sheet 2 of 5	

PRODUCT NUMBER	DESCRIPTION	NOTES
10117771-XXXXLF	NON-HF	SEE SHT. 3
10117771-XXXXHLF	HALOGEN FREE (H)	SEE SHT. 3

PRODUCT NUMBER (HALOGEN FREE) SEE NOTE 11	AWG	"DIM L" LENGTH (Meters)	"DIM M" HIEGHT (mm)
10117771-5030HLF	24 AWG	3 M	(20.1)
10117771-5040HLF	24 AWG	4 M	(20.1)
10117771-5050HLF	24 AWG	5 M	(20.1)
10117771-5060HLF	24 AWG	6 M	(20.1)
10117771-5070HLF	24 AWG	7 M	(20.1)
10117771-5080HLF	24 AWG	8 M	(20.1)
10117771-5090HLF	24 AWG	9 M	(20.1)
10117771-5100HLF	24 AWG	10 M	(20.1)
10117771-4020HLF	26 AWG	2 M	(20.1)
10117771-4030HLF	26 AWG	3 M	(20.1)
10117771-4040HLF	26 AWG	4 M	(20.1)
10117771-4050HLF	26 AWG	5 M	(20.1)
10117771-4060HLF	26 AWG	6 M	(20.1)
10117771-4070HLF	26 AWG	7 M	(20.1)
10117771-4080HLF	26 AWG	8 M	(20.1)
10117771-3010HLF	28 AWG	1 M	(17.3)
10117771-3020HLF	28 AWG	2 M	(17.3)
10117771-3030HLF	28 AWG	3 M	(17.3)
10117771-3040HLF	28 AWG	4 M	(17.3)
10117771-3050HLF	28 AWG	5 M	(17.3)
10117771-3060HLF	28 AWG	6 M	(17.3)
10117771-2005HLF	30 AWG	0.5 M	(17.3)
10117771-2010HLF	30 AWG	1 M	(17.3)
10117771-2020HLF	30 AWG	2 M	(17.3)
10117771-2030HLF	30 AWG	3 M	(17.3)
10117771-2040HLF	30 AWG	4 M	(17.3)

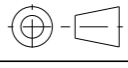
PRODUCT NUMBER (NON-HALOGEN FREE)	AWG	"DIM L" LENGTH (Meters)	"DIM M" HIEGHT (mm)
10117771-5030LF	24 AWG	3 M	(20.1)
10117771-5040LF	24 AWG	4 M	(20.1)
10117771-5050LF	24 AWG	5 M	(20.1)
10117771-5060LF	24 AWG	6 M	(20.1)
10117771-5070LF	24 AWG	7 M	(20.1)
10117771-5080LF	24 AWG	8 M	(20.1)
10117771-5090LF	24 AWG	9 M	(20.1)
10117771-5100LF	24 AWG	10 M	(20.1)
10117771-4020LF	26 AWG	2 M	(20.1)
10117771-4030LF	26 AWG	3 M	(20.1)
10117771-4040LF	26 AWG	4 M	(20.1)
10117771-4050LF	26 AWG	5 M	(20.1)
10117771-4060LF	26 AWG	6 M	(20.1)
10117771-4070LF	26 AWG	7 M	(20.1)
10117771-4080LF	26 AWG	8 M	(20.1)
10117771-3010LF	28 AWG	1 M	(17.3)
10117771-3020LF	28 AWG	2 M	(17.3)
10117771-3030LF	28 AWG	3 M	(17.3)
10117771-3040LF	28 AWG	4 M	(17.3)
10117771-3050LF	28 AWG	5 M	(17.3)
10117771-3060LF	28 AWG	6 M	(17.3)
10117771-2005LF	30 AWG	0.5 M	(17.3)
10117771-2010LF	30 AWG	1 M	(17.3)
10117771-2020LF	30 AWG	2 M	(17.3)
10117771-2030LF	30 AWG	3 M	(17.3)
10117771-2040LF	30 AWG	4 M	(17.3)

dr	Deborah Ingram	2011/03/17	projection 	size	A3	scale	1:1
eng	Deborah Ingram	2012/01/26		ecn no	-		
chr	-	-		rel level	Released		
appr	Brad Brubaker	-	product family	C&A			
		title Mini SAS HD 4X TO Mini SAS 2.1 TRAINED UNIVERSAL FINAL ASSEMBLY (6Gb/s)		dwg no 10117771	rev A		
www.fci.com		cat. no.	-	Product - Customer Drw		sheet 3 of 5	



Copyright FCI.

PRODUCT NUMBER	DESCRIPTION	NOTES
10117771-XXXXLF	NON-HF	SEE SHT. 3
10117771-XXXXHLF	HALOGEN FREE (H)	SEE SHT. 3

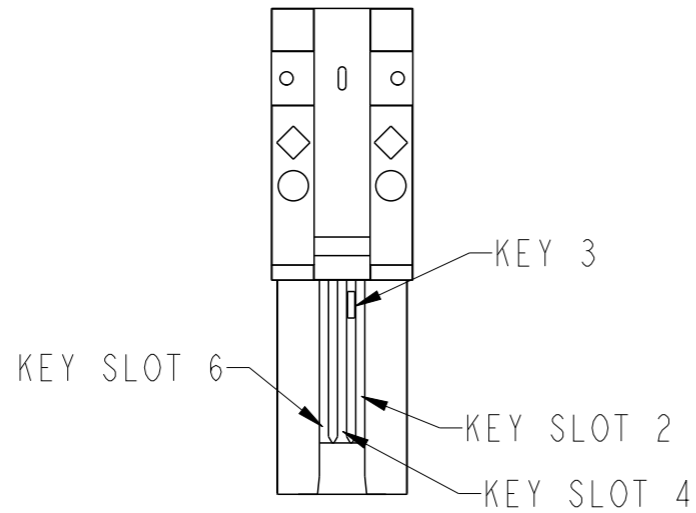

KEY 3 & KEY SLOT 2,4 & 6
 ○ ◇ UNIVERSAL PORT

**END P2
MINI SAS**

WIRING LIST (SEE NOTE 6)				
P1 (MINI SAS HD)		CONDUCTOR #	P2 (MINI SAS)	
SIGNAL	PIN#		PIN#	SIGNAL
GND	A9		B7	GND
Rx 1-	A5	PAIR 2	B6	Tx 1-
Rx 1+	A4		B5	Tx 1+
GND	A3		B4	GND
Rx 3-	A8	PAIR 4	B12	Tx 3-
Rx 3+	A7		B11	Tx 3+
GND	A6		B13	GND
N/C	A1	NO THRU CONNECTION		
Interrupt	A2			
GND	B9			GND
RX 0-	B5	PAIR 1	B3	TX 0-
RX 0+	B4		B2	TX 0+
GND	B3		B1	GND
RX 2-	B8	PAIR 3	B9	TX 2-
RX 2+	B7		B8	TX 2+
GND	B6		B10	GND
N/C	B1	NO THRU CONNECTION		
Mod_PRS_L (GND)	B2			
GND	C9		A7	GND
TX 1-	C5	PAIR 2	A6	RX 1-
TX 1+	C4		A5	RX 1+
GND	C3		A4	GND
TX 3-	C8	PAIR 4	A12	RX 3-
TX 3+	C7		A11	RX 3+
GND	C6		A13	GND
SCL	C1	NO THRU CONNECTION		
SDA	C2			
GND	D9			GND
TX 0-	D5	PAIR 1	A3	RX 0-
TX 0+	D4		A2	RX 0+
GND	D3		A1	GND
TX 2-	D8	PAIR 3	A9	RX 2-
TX 2+	D7		A8	RX 2+
GND	D6		A10	GND
N/C	D1	NO THRU CONNECTION		
V+3.3 for EEPROM	D2			
SHELL		BRAID		SHELL

dr	Deborah Ingram	2011/03/17	projection	MM	size	A3	scale	1:1
eng	Deborah Ingram	2012/01/26			product family	C&A	ecn no	-
chr	-	-				rel level	Released	
appr	Brad Brubaker	-						
	Mini SAS HD 4X TO Mini SAS 2.1		dwg no	10117771	rev	A		
www.fci.com	cat. no.	-	Product - Customer Drw	sheet 4 of 5				

PRODUCT NUMBER	DESCRIPTION	NOTES
10117771-XXXXLF	NON-HF	SEE SHT. 3
10117771-XXXXHLF	HALOGEN FREE (H)	SEE SHT. 3

NOTES:

- 1 - MATERIALS MINI SAS HD (END P1)
 BACK SHELLS: ZINC DIE CAST/ COPPER UNDER PLATE/NICKEL OVER PLATE
 PULL TAB: THERMOPLASTIC POLYMER
 LATCH: STAINLESS STEEL
 FERRULE: BRASS
 EMI GASKETS: STAINLESS STEEL
 LOCTITE
 HEAT SHRINK: HIGH POLYMERS
 PADDLE CARD: PRINTED CIRCUIT SUBSTRATE
- MATERIALS MINI SAS (END P2)
 BACK SHELLS: ZINC DIE CAST
 PULL TAB: THERMOPLASTIC POLYMER
 LATCH: STAINLESS STEEL
 JET MELT: POLYAMIDE POLYMER
 HEAT SHRINK: POLYOLEFIN
 PADDLE CARD: PRINTED CIRCUIT SUBSTRATE
- 2 - ELECTRICAL PERFORMANCE PER CURRENT REVISION: T10/SAS-2.1
- 3 - THIS PRODUCT MEETS THE RESTRICTION OF HAZARDOUS SUBSTANCES IN ELECTRICAL AND ELECTRONIC EQUIPMENT (RoHS) DIRECTIVE (2002/95/EC)
- 4 - UNLESS OTHERWISE SPECIFIED ASSEMBLED LENGTH TOLERANCE IS TO BE:
 "DIM L" < 1 METERS = ±25mm
 "DIM L" = 1 METER TO 4 METER = 2% OF "DIM L"
- 5- LABEL DETAILS:
 MANUFACTURER CODE OR NAME COUNTRY ORIGIN
 CUSTOMER P/N OR FCI P/N
 REVISION
 DATE CODE (YY/MM/DD FORMAT) - SERIAL NUMBER

 FONT SHALL BE CLEARLY VISIBLE AND BLACK IN COLOR.
- 6 - ALL CABLE ASSEMBLIES SHALL BE 100% TESTED FOR CONTINUITY AS DEFINED IN WIRING LIST.
- 7 - PACKAGING OF LEAD FREE PRODUCTS MEETS LABELING AND PACKAGING PER SPECIFICATION GS-14-920. PACKAGE ASSEMBLIES PER GS-14-1272. DUST COVER IS TO BE APPLIED TO MINI SAS HD CONNECTOR PRIOR TO SHIPPING.
- 8- THIS DIMENSION IS A FINISHED PRODUCT LENGTH.
9. A "△" SYMBOL WILL BE NEXT TO ANY DIMENSION, VIEW, OR NOTE WHICH HAS BEEN MODIFIED WITH THE CURRENT DRAWING REVISION. THE CURRENT REVISION WILL BE SHOWN IN THE SYMBOL.
10. PLACE A CABLE TIE EVERY 0.5 METERS, IN THE CASE OF A 0.5 METER CABLE LENGTH, PLACE THE CABLE TIE MIDWAY BETWEEN CONNECTORS.
11. "H" IN THE PART NUMBER DENOTES USE OF HALOGEN FREE CABLE.
12. MEETS ELECTRICAL PERFORMANCE REQUIREMENTS OF SAS 2.1.
13. MATES TO SERIES: MINI SAS HD - 10112626 or 10112627 or 10112628
 MINI SAS 2.1 - BOARD CONNECTOR 10098870 AND CAGE 10098871
14. OTHER TESTING PERFORMED AS REQUIRED BY PRODUCT SPECIFICATION: MINI SAS HD GS-12-651, MINI SAS 2.1 GS-12-548.

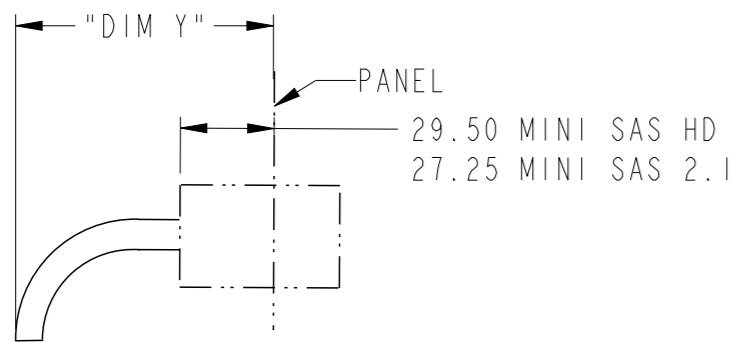

PEND RADIUS
TOP VIEW OF CONNECTOR

MINI SAS HD MINIMUM BEND TABLE		
CABLE	"DIM Y" (HF)	"DIM Y" (NON-HF)
24 AWG	92.8	90.5
26 AWG	87.5	85.1
28 AWG	81.5	79.1
30 AWG	77.9	74.3

MINI SAS 2.1 MINIMUM BEND TABLE		
CABLE	"DIM Y" (HF)	"DIM Y" (NON-HF)
24 AWG	90.6	88.3
26 AWG	85.3	82.9
28 AWG	79.3	76.9
30 AWG	75.7	72.1

dr	Deborah Ingram	2011/03/17	projection	MM	size	A3	scale	1:1
eng	Deborah Ingram	2012/01/26				ecn no	-	
chr	-	-	product family	C&A		rel level	Released	
appr	Brad Brubaker	-			dwg no	10117771	rev	A
www.fci.com		cat. no.	-	Product - Customer Drw	sheet 5 of 5			



Copyright FCI.