

SPECIFICATIONS

RECOMMENDED EXCITATION (8VDC MIN)	10.000±.010 VDC (15.000VDC MAX)
POWER CONSUMPTION	30mW TYP
OUTPUT VOLTAGE TRIM POINT	20mV @ 2" H ₂ O
NULL VOLTAGE	0.0±1.0 mV
NULL VOLTAGE SHIFT (-25°C TO +85°C)	±1.5 mV (MAX)
OUTPUT VOLTAGE SHIFT (+25°C TO -25°C) (+25°C TO +85°C)	+22.0% READING (MAX) -22.0% READING (MAX)
REPEAT. & HYST.	±1 %F.S.O. (MAX)
RESPONSE TIME	3.0 msec (MAX)
OPERATING TEMP RANGE	-25°C TO +85°C
STORAGE TEMP RANGE	-40°C TO +90°C
TERMINATION	.025 SQ. IN.
WEIGHT	10.8 GRAMS
SHOCK RATING	100 G PEAK
OVERPRESSURE	5 PSI (MAX)
SENSOR RESISTANCE	5K OHMS (TYP)
SENSOR CURRENT (PIN 2-PIN 1, PIN 6-PIN 1)	0.6 mA (MAX)

FLOW SPECIFICATIONS

PRESSURE ('H ₂ O)	NOMINAL (mV)	TOL (*mV)
4	31.75	8.00
3	26.75	6.00
2	20.00	3.00
1	11.20	4.00
0	0.00	1.00
-1	-11.20	7.00
-2	-20.00	7.00
-3	-26.75	11.00
-4	-31.75	15.00

HEATER CONTROL CIRCUIT

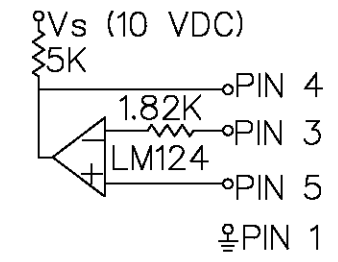

SENSING BRIDGE SUPPLY CIRCUIT

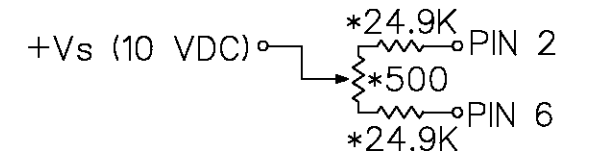

*USE TRIMPOT TO BALANCE Vs -PIN 2 AND Vs -PIN 6 RESISTANCE

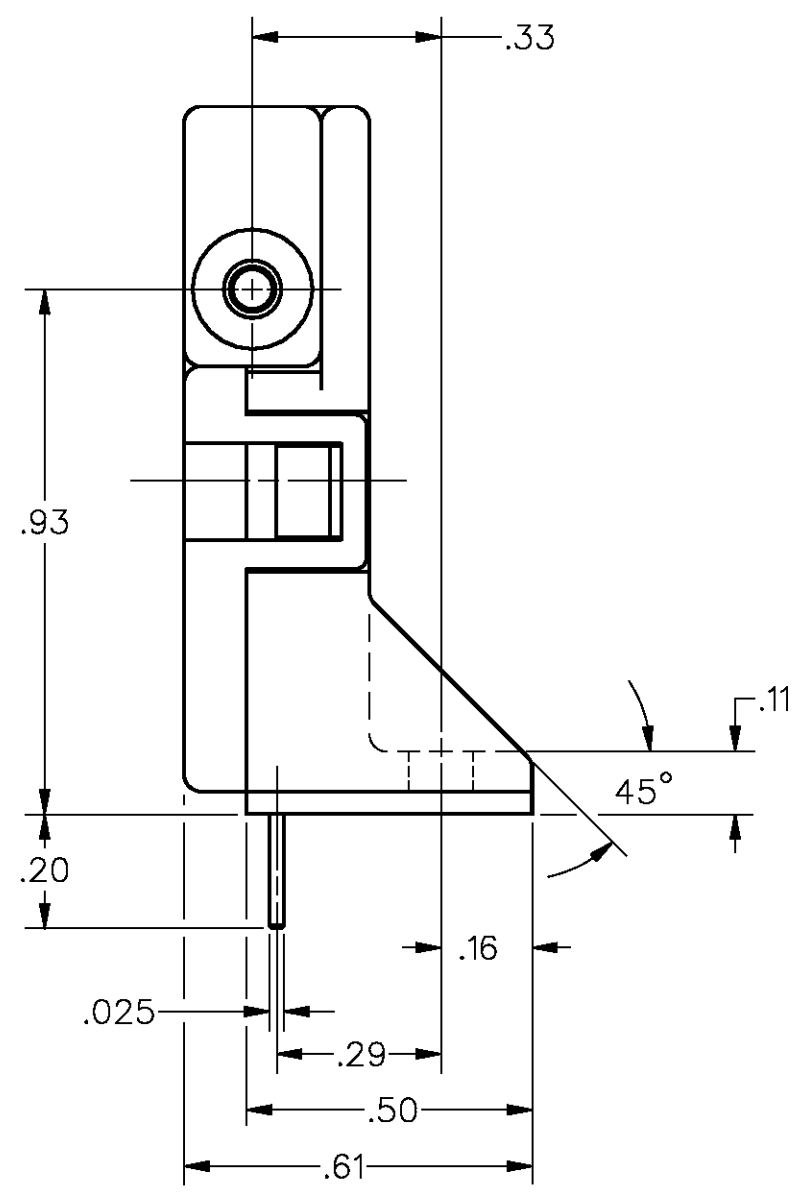
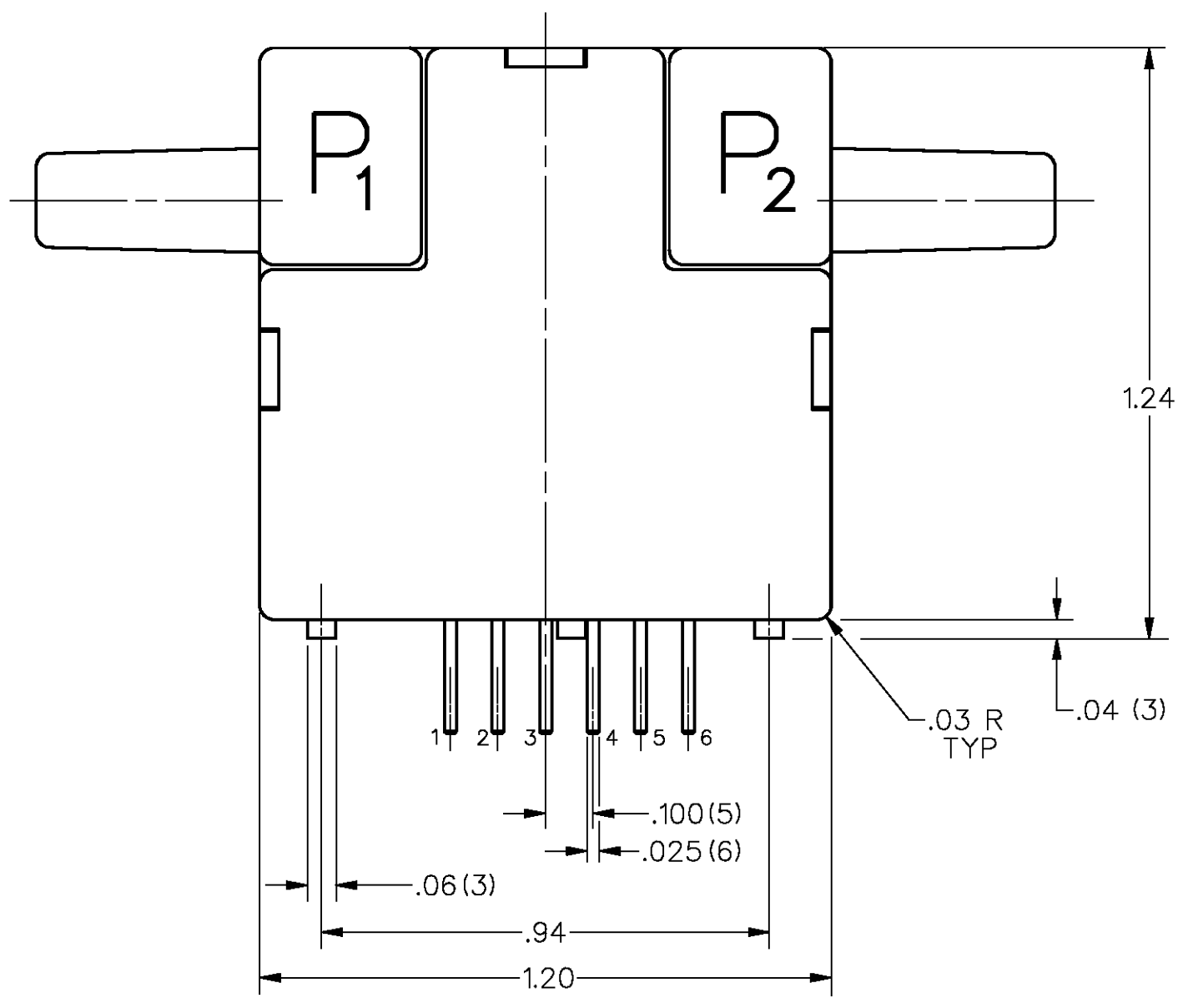
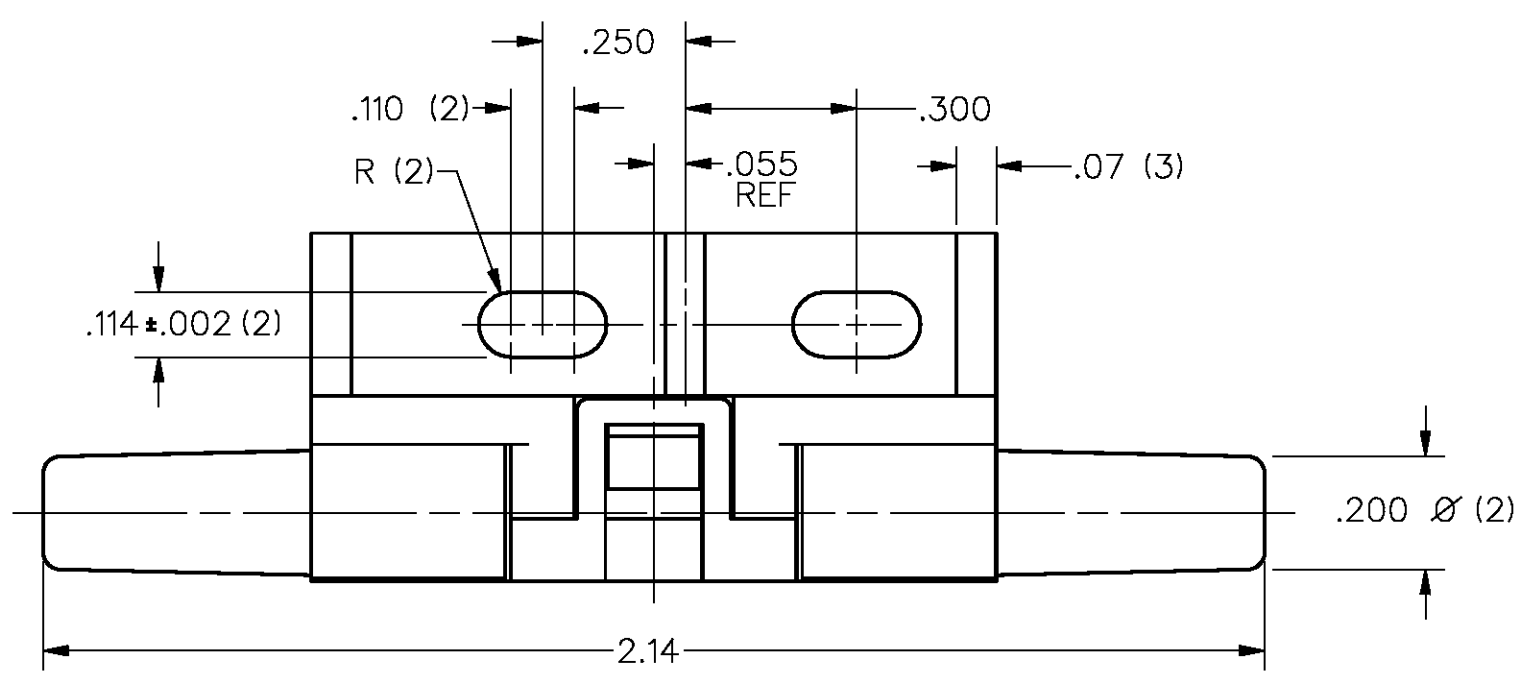

NOTES

- 1 RESPONSE TIME IS TYPICALLY 1 msec FROM 10-90%
- 2 OUTPUT VOLTAGE IS RATIOMETRIC TO SUPPLY VOLTAGE
- 3 REPEATABILITY & HYSTERESIS TOLERANCE REFLECT INHERENT INACCURACIES OF THE MEASUREMENT EQUIPMENT
- 4 TEMPERATURE SHIFTS IN THE DEVICES ARE MOSTLY DUE TO THE DENSITY CHANGE OF THE GAS OVER TEMPERATURE
- 5 - POSITIVE FLOW DIRECTION IS DEFINED AS PROCEEDING FROM P1 TO P2 AND RESULTS IN POSITIVE OUTPUT (PIN 6 > PIN 2) NEGATIVE FLOW DIRECTION IS DEFINED CONVERSELY AND RESULTS IN NEGATIVE OUTPUT (PIN 6 < PIN 2)

DRAWING NUMBER: AWM1200V
 PAGE 1 OF 1
 RELEASE NO. PR-20470 REPLACES X96706-AW
 ISSUE 4
 REVISIONS:
 A 83279 7 SEP 86
 B C083694 29 APR 97
 C C094378 23 MAR 99
 FORMTEK DRAWN J A F 22 JAN 93 CHECK K A G 23 JAN 93

MASTER REDUCED

THIS DRAWING COVERS A PROPRIETARY ITEM AND IS THE PROPERTY OF MICRO SWITCH, A DIVISION OF HONEYWELL. THIS DRAWING IS NOT TO BE COPIED OR USED WITHOUT THE APPROVAL OF MICRO SWITCH.		CATALOG LISTING	
MICRO SWITCH a Honeywell Division		AWM1200V	
FED. MFG. CODE 91929		WEIGHT	

THIRD ANGLE PROJECTION	
SCALE 3 : 1	
DO NOT SCALE PRINT	
UNLESS OTHERWISE SPECIFIED TOLERANCES ARE	
ONE PLACE	(.0) ±.030
TWO PLACES	(.00) ±.015
THREE PLACES	(.000) ±.005
ANGLES	±