

# Amphenol<sup>®</sup> RF

Global RF Solutions

## NPI Qualification Test Report

DVT #: 3213

EAR: 5916

DVT Rev: 1

Date: 1/13/2014

SMA Jack to AMC (U.FL) Probe Adapter

Amphenol RF P/N : 901-10465

Rev : A

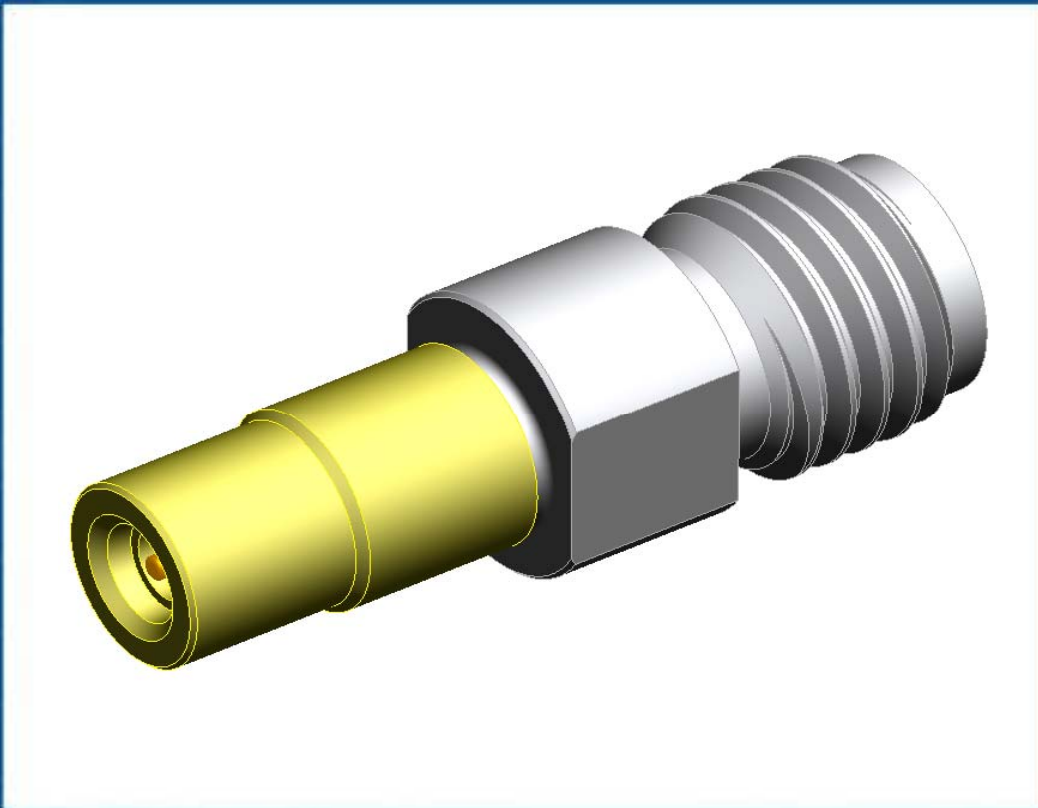

Environmental, Mechanical and Electrical  
Performance Test Results

NOTES:

1. MATERIALS AND FINISHES:  
 BODY - BRASS, NICKEL PLATING  
 HOOD - STAINLESS STEEL, GOLD PLATING  
 CONTACTS - BERYLLIUM COPPER OR BRASS, GOLD PLATING (4 MICROINCHES MIN)  
 INSULATOR - PTFE
2. ELECTRICAL:  
 A. IMPEDANCE: 50 OHM  
 B. FREQUENCY RANGE: DC - 6 GHz  
 C. VSWR: 1.25 MAX.  
 D. DIELECTRIC WITHSTANDING VOLTAGE: 250 VRMS, MIN.
3. MECHANICAL:  
 A. DURABILITY: 5000 CYCLES MIN.  
 B. TEMPERATURE RANGE: -65° C TO +165° C
4. PACKAGING:  
 A. QUANTITY: SINGLE PACK  
 B. MARKING: BAG TO BE MARKED  
 \*AMPHENOL RF, 901-10465, AND DATE CODE"

THIRD ANGLE PROJ.

REVISIONS

REV	DESCRIPTION	DATE	ECO	APPR
A	RELEASE TO MFG.		49879	JTS

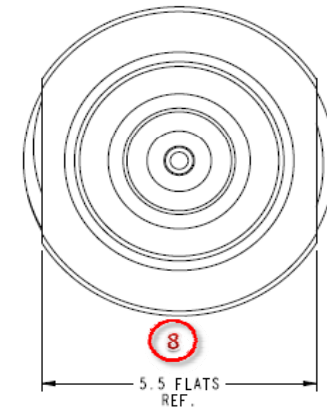
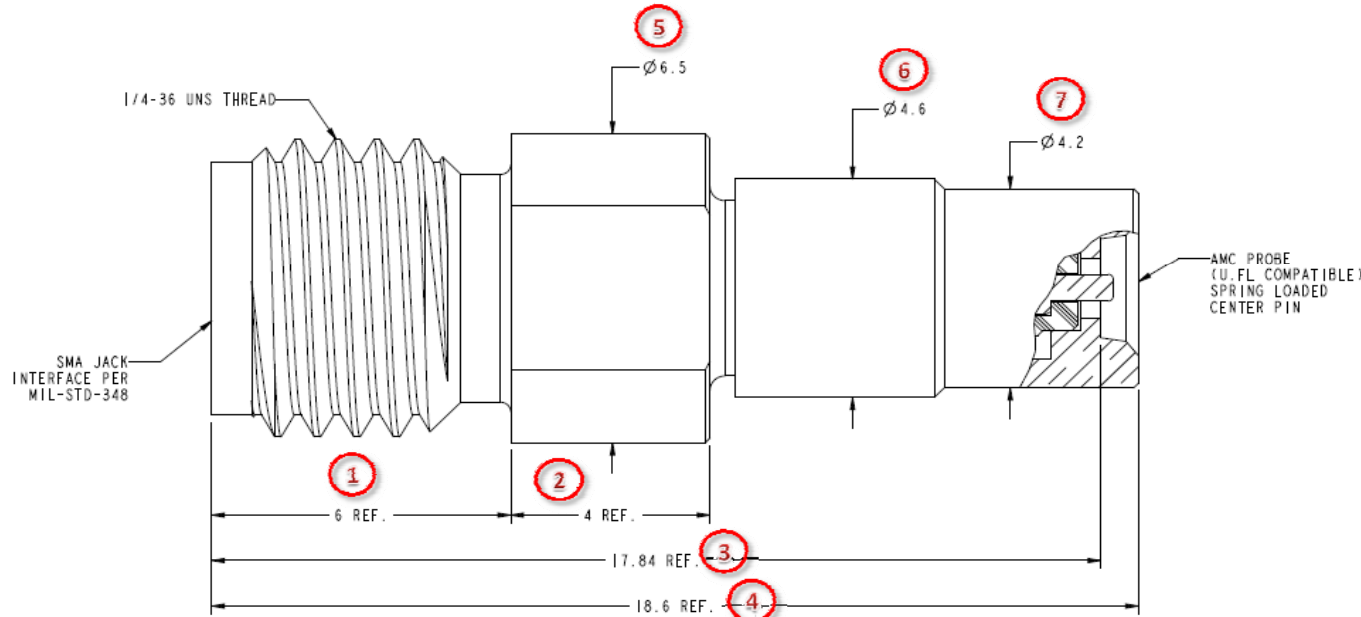
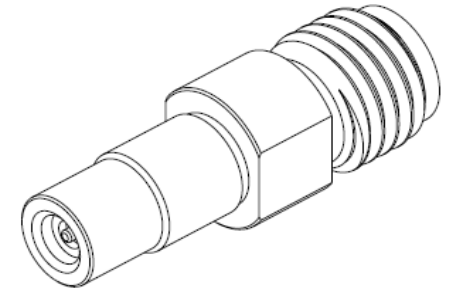

**CUSTOMER OUTLINE DRAWING**  
 ALL OTHER SHEETS ARE FOR INTERNAL USE ONLY

UNLESS OTHERWISE SPECIFIED, DIMENSIONS ARE IN METRIC AND TOLERANCES ARE: <0.5mm ±0.05mm    0.5 - 6mm ±0.1mm    6 - 30mm ±0.2mm    30 - 120mm ±0.3mm    ANGLES ±1°	MATERIAL	DRAWN T. SMITH	DATE 04-Oct-13	TITLE AMC PROBE (U.FL) TO SMA JACK ADAPTER	Amphenol RF www.amphenolrf.com
	NOTICE - These drawings, specifications, or other data (1) are, and remain the property of Amphenol corp. (2) must be returned upon request; and (3) are confidential and not to be disclosed to any person other than those to whom they are given by Amphenol Corp. The furnishing of these drawings, specifications, or other data by Amphenol Corp., or to any other person to anyone for any purpose is not to be regarded by implication or otherwise in any manner licensing, granting rights to permitting such holder or any other person to manufacture, use or sell any product, process or design, patented or otherwise, that may in any way be related to or disclosed by said drawings, specifications, or other data.	REFERENCE EAR #5916	ENGINEER T. SMITH		
	CONFIGURATION LEVEL: FINISH	APPROVED	DATE	SCALE: 10.0:1.0 SHEET 2 OF 2	ITEM NO. 901-10465
		CAD FILE		DWG SIZE B	REV A
					PART NO. 901-10465

\* Form varies by test parameter

Amphenol <sup>®</sup> RF Global RF Solutions		DESIGN VERIFICATION AND VALIDATION TEST PLAN		
<b>Customer:</b>	<b>Distribution</b>	<b>Design Engineer:</b>	<b>Todd Smith</b>	
<b>DVT Number:</b>	<b>3213</b>	<b>Program Manager:</b>	<b>Rahul Rajan</b>	
<b>DVT Rev:</b>	<b>1</b>	<b>Amphenol PN:</b>	<b>901-10465</b>	
<b>EAR Number:</b>	<b>5916</b>	<b>Amphenol Rev:</b>	<b>A</b>	
<b>Description:</b>	<b>SMA Jack to AMC (U.FL) Probe Adapter</b>			
*Individual Dimensional, Mechanical, Electrical and Environmental tests are part specific and not controlled by this document.				
Testing Required by Design Engineer to Verify Design and Validate Product Performance	Description of Testing Requirement	Test Assy's Req.	Assy's that will be lost	Result
<b>Dimensional Tests</b>				
First Article Inspection	As indicated on Customer Outline Drawing.	5	0	Pass
<b>Appearance</b>				
Assembly appearance	Include photo of the complete assembly, to show the appearance.	1	0	Pass
<b>Mechanical Tests</b>				
Component Weight	Product weight in grams.	1	0	Pass
Plating Thickness	The parts must conform to Amphenol Plating spec. 349-50560. Body: nickel plating 100 microinches minimum thickness over copper strike. Hood and contacts: gold plating 5 microinches minimum thickness over 100 microinches minimum high phosphorus electroless nickel.	1	0	Pass
Contact Captivation - Axial	Contact must withstand a 6 Lbf push out force applied from mating direction and meet the interface dimensions shown on dwg.	2	2	Pass
Body Captivation - Axial	Body must withstand an axial force of 20 Lbf and maintain dimensions shown on drawing.	2	2	Pass
Spring Force	Measure spring force when mating to AMC jack (A-1JB).	5	0	Pass
Cycle Testing	Cycle 5000 times by mating to AMC jack (A-1JB). Measure spring force and contact resistance after every 1000 cycles.	5	0	Pass
<b>Electrical Tests</b>				
Contact Resistance	Determine the electrical resistance of both outer conductor crimps and corresponding interface and the inner conductor crimps and corresponding contact interface under low energy conditions; The total contact resistance of inner conductor must not exceed 50 mΩ. Likewise, max contact resistance of the outer conductor must not exceed 50 mΩ.	All	0	Pass
Continuity Test	Verify the DUT shows no open OR short circuits.	All	0	Pass
Dielectric Withstanding Voltage	Demonstrate the connection can withstand momentary over-potentials due to switching, surges and other similar phenomena; Apply 500 VRMS, 60 Hz for 60 seconds. A buzzing noise indicates failure.	All	0	Pass
VSWR / Return Loss	Verify the efficiency of voltage applied to voltage reflected is adequate to the product application; Max VSWR should be 1.25 : 1 @ 6 GHz. Include a screenshot of NA results.	5	0	Pass
Insertion Loss	Verify the total loss of power going through the DUT; record maximum insertion loss. Include a screenshot of NA results.	5	0	Pass
Amphenol Best Practices	Quality shall apply Amphenol Best Practices verification as applicable to this product.	All	0	Pass
<b>Design Engineer Comments:</b>	When required include photo of test equipment when performing a test.			
Total Testing Requirements Identified for Verification of Design Intent and Validation of Customer Requirements			Parts Destroyed	4

Amphenol <sup>®</sup> RF Global RF Solutions		FIRST ARTICLE / PART EVALUATION INSPECTION											
Amphenol P/N		Revision	Mfg Order #		Mfg Location			Supplier Name		Sup. #	Date		
901-10465		A	5525-131108003		Amphenol RF ASIA			-		-	1/13/2014		
Customer P/N		Revision	EAR #		Design Eng			Prog. Mgr.		Evaluated BY			
-		-	5916		Todd Smith			Rahul Rajan		Michael Li			
Part Description					LOT QTY		PO#		DVT Number				
SMA Jack to AMC (U.FL) Probe Adapter					100		-		3213				
<input checked="" type="checkbox"/> First Article Inspection (all dimensions on COD). <input type="checkbox"/> Critical Dimension Inspection Only (defined by Engineering). <input type="checkbox"/> Material Environmental Compliance Documented. <input type="checkbox"/> AQL Supplier Verification.													
Item	Nominal	UCL	LCL	Sample #1	Sample #2	Sample #3	Sample #4	Sample #5	Gage				
1	6.00	REF	REF	6.00	5.99	6.00	6.01	6.00	Digital Mic				
2	4.00	REF	REF	4.05	4.04	4.06	4.06	4.05	Digital Cal				
3	17.84	REF	REF	17.84	17.89	17.86	17.87	17.85	Height Gage				
4	18.60	REF	REF	18.62	18.67	18.65	18.66	18.64	Digital Cal				
5	6.50	0.20	0.20	6.42	6.43	6.44	6.43	6.42	Digital Cal				
6	4.60	0.10	0.10	4.63	4.62	4.60	4.61	4.62	Digital Cal				
7	4.20	0.10	0.10	4.20	4.21	4.21	4.20	4.21	Digital Cal				
8	5.50	0.10	0.10	5.50	5.51	5.51	5.50	5.50	Digital Cal				
9													
10													
11													
12													
13													
14													
15													
16	Cont. (Opens & Shorts)		Pass	Parts were 100 % tested as per DVT requirements.									
17	Hi-Pot test		Pass	Parts were 100 % tested as per DVT requirements.									
18	Orientation		Pass	Parts were checked 100 % as per DVT requirements.									
19	Packaging Type		Single										
20	Packaging QTY		1										
21	Marker #1	Na											
22	Marker #2	Na											
23	Marker #3	Na											
24	Marker #4	Na											
25	Marker #5	Na											
26													
<b>Comments:</b>													
Appearance is okay.													
Thread has been verified with GO-NOGO gauge, result is acceptable.													
<b>PROTOTYPE ENGINEERING VALIDATION</b>						<b>QUALITY ENGINEERING VALIDATION</b>							
<input checked="" type="checkbox"/> Processed through all assembly steps without major issue. <input type="checkbox"/> Additional manufacturing testing and validation required. <input checked="" type="checkbox"/> Manufacturing Process is ready (Including Work Instructions as needed).						<input checked="" type="checkbox"/> Measurements and DVT Plan are adequate for product quality. <input type="checkbox"/> Process controls (Including inspection plans in place as needed). <input type="checkbox"/> Manufacturing equipment is production ready.							
<b>PART EVALUATION REPORT DISPOSITION (See comments section for detailed REPAIR or REWORK instructions)</b>													
Department		Initials		Date		Signature		Pass		Rework		Fail	
Design Engineer		TS		1/13/2014		Todd Smith		☑		☐		☐	
Manufacturing Engineer		DW		1/13/2014		Dico Wang		☑		☐		☐	
Quality Engineer		ML		1/13/2014		Michael Li		☑		☐		☐	
Quality Technician		SS		1/13/2014		Stone Shi		☑		☐		☐	



# ASSEMBLY APPEARANCE

Amphenol RF ASIA  
 Block DM2 Tang Wei Industrial, General CO.Gong Ming Town,  
 Bao An District, Shen Zhen City, China

Supplier	Part Number	Rev Level	DVT #	EAR #
Amphenol RF ASIA	901-10465	A	3213	5916
Name of Laboratory	Part Name		Date of Test	
Amphenol RF ASIA	SMA Jack to AMC (U.FL) Probe Adapter		January 13, 2014	

Include photo of the complete assembly, to show the appearance.



Signature	Title
<i>Linas Hu</i>	Quality Technician

## COMPONENT WEIGHT

Amphenol RF ASIA

 Block DM2 Tang Wei Industrial, General CO.Gong Ming Town,  
 Bao An District, Shen Zhen City, China

Supplier <b>Amphenol RF ASIA</b>	Part Number <b>901-10465</b>	Rev Level <b>A</b>	DVT # <b>3213</b>	EAR # <b>5916</b>
Name of Laboratory <b>Amphenol RF ASIA</b>	Part Name <b>SMA Jack to AMC (U.FL) Probe Adapter</b>			Date of Test <b>January 13, 2014</b>

**Test Method/Requirements:**

Product weight in grams.

SAM #	REQUIREMENTS	Qty	Grams
1	Weigh one sample and record the data	1	2.03

## PLATING THICKNESS

**Test Method/Requirements:**

The parts must conform to Amphenol Plating spec. 349-50560.

Body: nickel plating 100 microinches minimum thickness over copper strike.

Hood and contacts: gold plating 5 microinches minimum thickness over 100 microinches minimum high phosphorus electroless nickel.

SAM #	REQUIREMENTS	QTY	RESULT
	BODY: NICKEL PLATE 100 MICROINCHES MIN THICK OVER COPPER STRIKE.	1	Ni = 106.2 µin
	CONTACT: GOLD PLATE 5 MICROINCHES MIN THICK OVER PHOSPHORUS CONTENT (9%-13%) ELECTROLESS NICKEL PLATE 100 MICROINCHES MIN THICK	1	Au = 6.22 µin
	CONTACT: GOLD PLATE 5 MICROINCHES MIN THICK OVER PHOSPHORUS CONTENT (9%-13%) ELECTROLESS NICKEL PLATE 100 MICROINCHES MIN THICK	1	Au = 6.17 µin
	BODY: GOLD PLATE 5 MICROINCHES MIN THICK OVER PHOSPHORUS CONTENT (9%-13%) ELECTROLESS NICKEL PLATE 100 MICROINCHES MIN THICK	1	Au = 7.39 µin

**Jadever®  
JBX-1.5K  
Electronic  
Balance**  
Instrument  
range:  
0 ~ 1500g.



**Fischerscope® XDAL**, this instrument is an energy-dispersive X-ray fluorescence spectrometer capable of performing both quantitative element analysis and thickness measurement in one integrated measurement system. The XDAL can analyze solid samples, as well as powder, paste-like materials and liquids for up to 24 elements from Al (Z=13) to U (Z=92). In addition, coating thickness and composition of complex multi-layer coating systems with up to 24 different coating layers can be measured.



Signature

*Stone Shi*

Title

Quality Technician



## BODY CAPTIVATION - AXIAL

Amphenol RF ASIA  
 Block DM2 Tang Wei Industrial, General CO.Gong Ming Town,  
 Bao An District, Shen Zhen City, China

Supplier <b>Amphenol RF ASIA</b>	Part Number <b>901-10465</b>	Rev Level <b>A</b>	DVT # <b>3213</b>	EAR # <b>5916</b>
Name of Laboratory <b>Amphenol RF ASIA</b>	Part Name <b>SMA Jack to AMC (U.FL) Probe Adapter</b>			Date of Test <b>January 13, 2014</b>

**Test Method and Specification:**

Body must withstand an axial force of 20 Lbf and maintain dimensions shown on drawing.

SAMPLE #	REQUIREMENTS	QTY Tested	Force	Dim (mm)	Fail
1	As above.	1	20	18.62	Pass
2		1	20	18.65	Pass

## CONTACT CAPTIVATION - AXIAL

**Test Method and Specification:**

Contact must withstand a 6 Lbf push out force applied from mating direction and meet the interface dimensions shown on dwg.

SAMPLE #	REQUIREMENTS	QTY Tested	Force	Dim (mm)	Fail
1	As above.	1	6	0.06	Pass
2		1	6	0.08	Pass

**CDI 1502LDIN Dial Torque Wrench**  
 Amphenol RF Asia's CDI 1502LDIN Dial Torque Wrench can test Torque Force with accuracy.  
 The range of the instrument is:  
 0 ~ 150 in-lb / 0 ~ 2421 in-oz.



**KQL® KD / Series Mechanical Force Tester**  
 Amphenol RF and Amphenol RF Asia's KQL® K / Series Mechanical Force Tester is utilized for tensile and compression testing up to 200 Lbs capacities.



Signature <i>RX Zhao</i>	Title <b>Assistant Engineer</b>
-----------------------------	------------------------------------

## Contact Mating Force

Amphenol RF ASIA

 Block DM2 Tang Wei Industrial, General CO.Gong Ming Town,  
 Bao An District, Shen Zhen City, China

Supplier <b>Amphenol RF ASIA</b>	Part Number <b>901-10465</b>	Rev Level <b>A</b>	DVT # <b>3213</b>	EAR # <b>5916</b>
Name of Laboratory <b>Amphenol RF ASIA</b>	Part Name <b>SMA Jack to AMC (U.FL) Probe Adapter</b>			Date of Test <b>January 13, 2014</b>

**Test Method and Specification:**

Measure spring force when mating to AMC jack (A-1JB).

SAMPLE #	REQUIREMENTS	QTY Tested	Force (N)	Result
1	As above.	1	3.8	Pass
2		1	2.8	Pass
3		1	3.3	Pass
4		1	3.2	Pass
5		1	3.1	Pass

### CONTACT MATING CYCLES

**Test Method and Specification:**

Cycle 5000 times by mating to AMC jack (A-1JB). Measure spring force and contact resistance after every 1000 cycles.

SAMPLE #	REQUIREMENTS	Cycles	Spring Force	LLCR	Result
1	Measure spring force and contact resistance after every 1000 cycles.	1000	2.4	32.8	Pass
		2000	2.4	34.1	Pass
		3000	2.2	36.8	Pass
		4000	2.2	28.5	Pass
		5000	2.0	32.2	Pass
2	Measure spring force and contact resistance after every 1000 cycles.	1000	2.7	24.5	Pass
		2000	2.3	17.2	Pass
		3000	2.0	18.4	Pass
		4000	2.2	18.7	Pass
		5000	2.2	16.1	Pass
3	Measure spring force and contact resistance after every 1000 cycles.	1000	2.9	16.6	Pass
		2000	2.8	20.7	Pass
		3000	2.8	17.8	Pass
		4000	2.6	16.4	Pass
		5000	2.6	13.7	Pass

#### Zwick Testing Machines

Single column testing machine for tensile, compression and cyclic testing up to 2.5kN (562 lbf).



Signature

*RX Zhao*

Title

Assistant Engineer



**CONTACT RESISTANCE**

Amphenol RF ASIA

Block DM2 Tang Wei Industrial, General CO.Gong Ming Town,  
Bao An District, Shen Zhen City, China

Supplier Amphenol RF ASIA	Part Number	Rev Level	DVT #	EAR #
	901-10465	A	3213	5916
Name of Laboratory Amphenol RF ASIA	Part Name SMA Jack to AMC (U.FL) Probe Adapter			Date of Test January 13, 2014

**Test Method/Requirements:**

Determine the electrical resistance of both outer conductor crimps and corresponding interface and the inner conductor crimps and corresponding contact interface under low energy conditions; The total contact resistance of inner conductor must not exceed 50 mΩ. Likewise, max contact resistance of the outer conductor must not exceed 50 mΩ.

SAMPLE #	REQUIREMENTS	INNER LLCR	OUTER LLCR	QTY Tested	RESULT
1	As above.	32.8	19.0	1	Pass
2		24.5	23.0	1	Pass
3		16.6	19.0	1	Pass

**High Resolution 380560 MilliOhm Meter**  
Provide 7 ranges for wide 20.00mΩ to 20.00kΩ low resistance measurements



**Analog high voltage Megohmmeter T0004** has two test voltages: 50V and 500V.



Signature  
*RX Zhao*

Title  
Assistant Engineer

## VSWR / RETURN LOSS

Amphenol RF ASIA

 Block DM2 Tang Wei Industrial, General CO.Gong Ming Town,  
 Bao An District, Shen Zhen City, China

Supplier <b>Amphenol RF ASIA</b>	Part Number <b>901-10465</b>	Rev Level <b>A</b>	DVT # <b>3213</b>	EAR # <b>5916</b>
Name of Laboratory <b>Amphenol RF ASIA</b>	Part Name <b>SMA Jack to AMC (U.FL) Probe Adapter</b>			Date of Test <b>January 13, 2014</b>

**Test Method/Requirements:**

Verify the efficiency of voltage applied to voltage reflected is adequate to the product application; Max VSWR should be 1.25 : 1 @ 6 GHz. Include a screenshot of NA results.

SAMPLE #	REQUIREMENTS	VSWR 1		Pass	Fail
1	VSWR 1.2:1 from DC to 6 GHz.	1.19		Pass	
2		1.17		Pass	
3		1.19		Pass	
4		1.20		Pass	
5		1.19		Pass	

After 5000 cycles:

1	VSWR 1.2:1 from DC to 6 GHz.	1.16		Pass	
2		1.16		Pass	
3		1.18		Pass	

## INSERTION LOSS

**Test Method/Requirements:**

Verify the total loss of power going through the DUT; record maximum insertion loss. Include a screenshot of NA results.

SAMPLE #	REQUIREMENTS	dB		Pass	Fail
1	Record maximum insertion loss.	0.15		Pass	
2		0.15		Pass	
3		0.13		Pass	
4		0.13		Pass	
5		0.16		Pass	

After 5000 cycles:

1	Record maximum insertion loss.	0.15		Pass	
2		0.19		Pass	
3		0.15		Pass	

**Agilent® N5230A Network Analyzer**

Amphenol RF and Amphenol RF Asia's N5230A Network Analyzer apply to test the electrical characteristics, include: Voltage Standing Wave Ratio, Insertion Loss, Return Loss, Smith Chart, etc.



Signature

*RX Zhao*

Title

Assistant Engineer

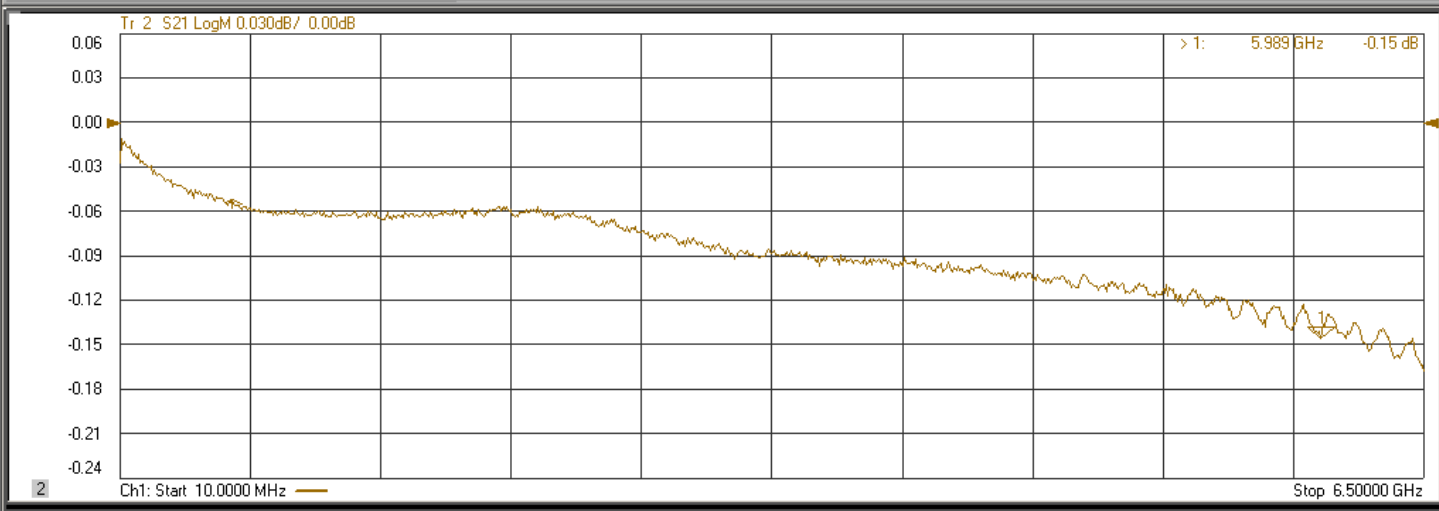
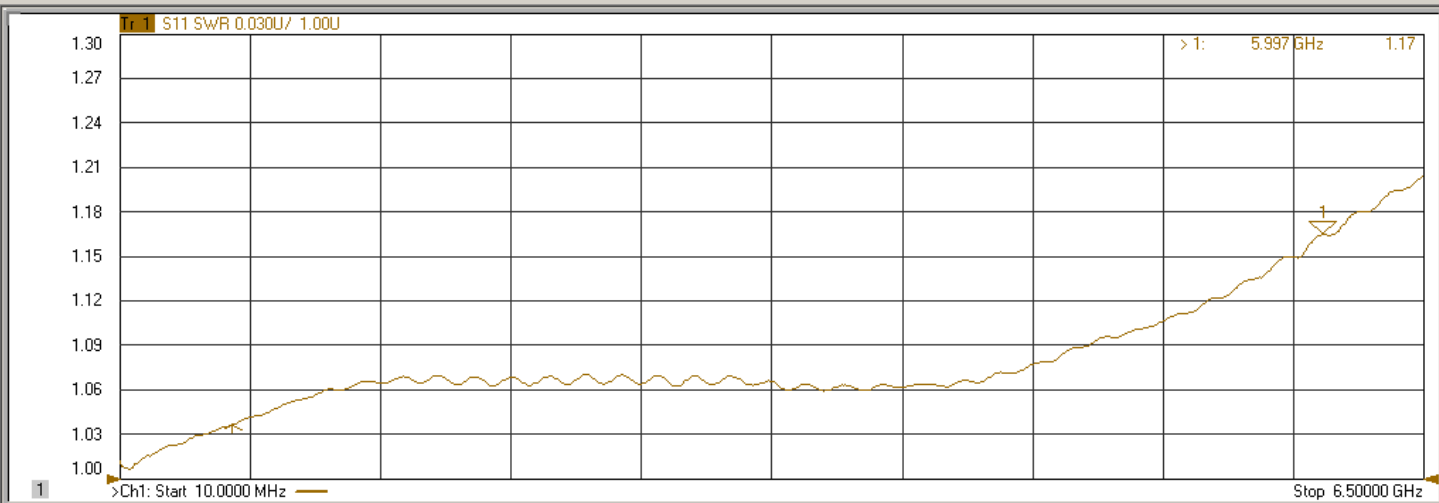
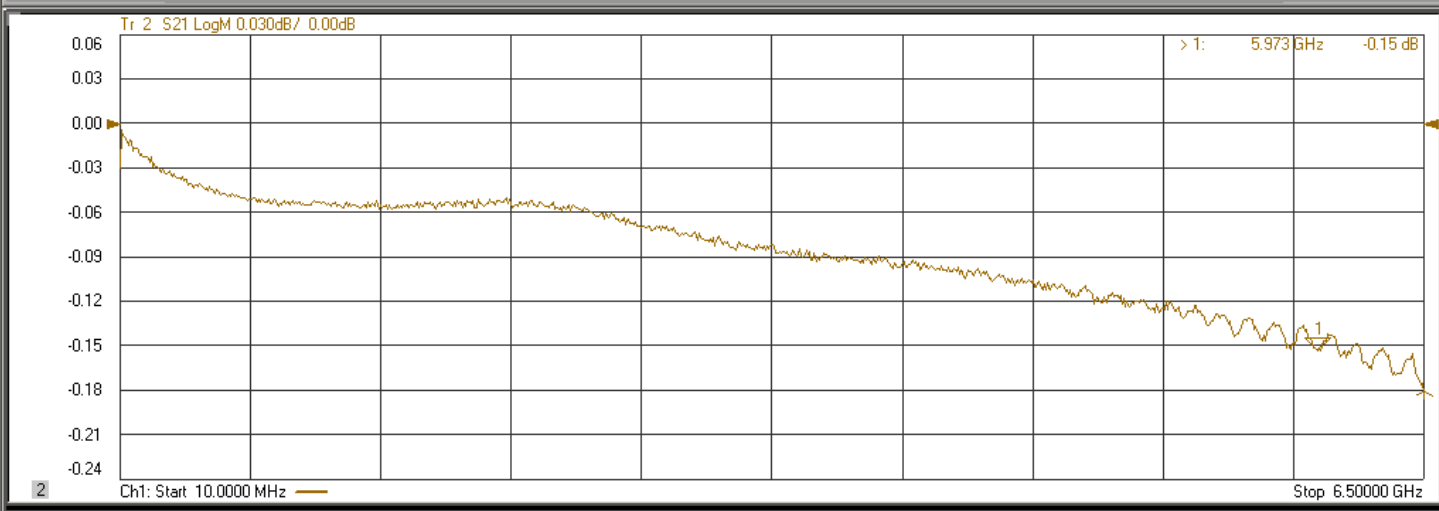
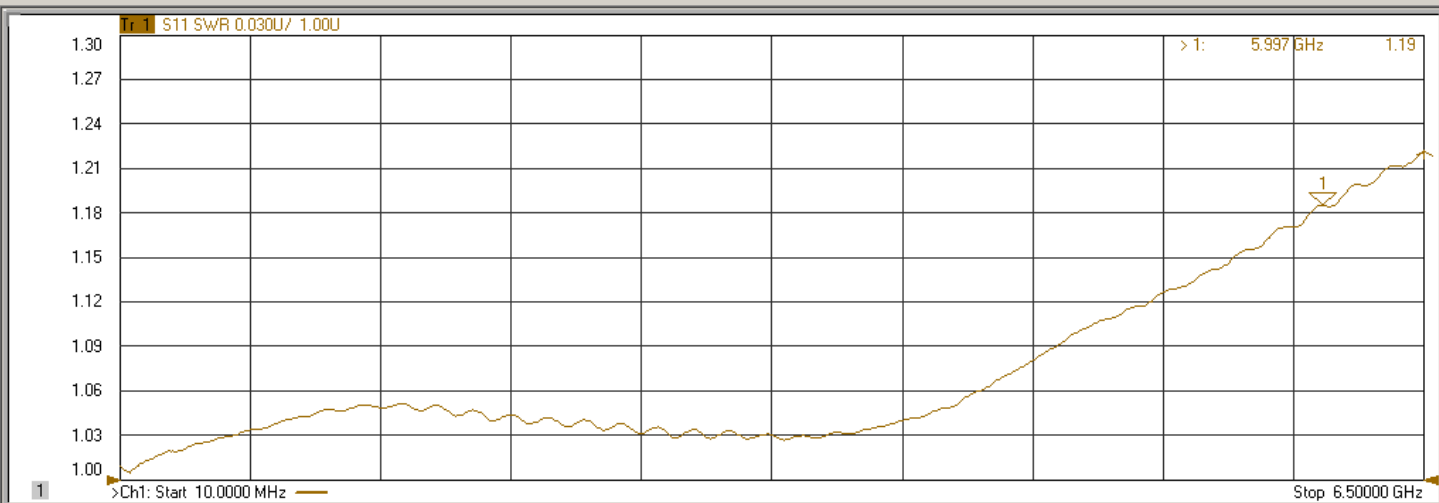

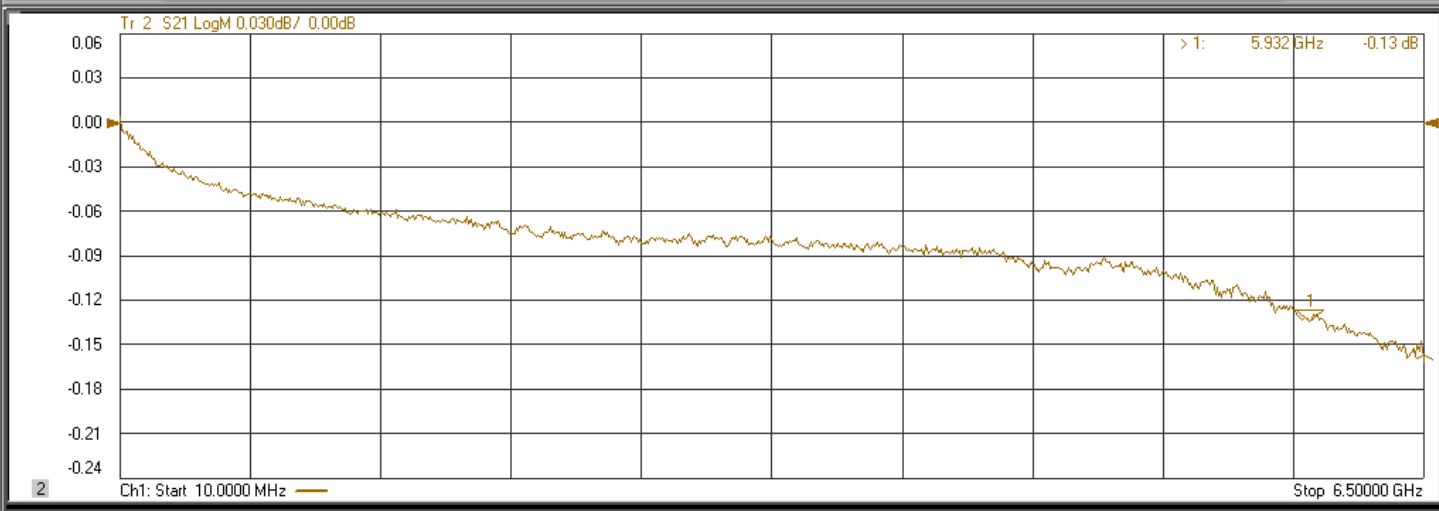
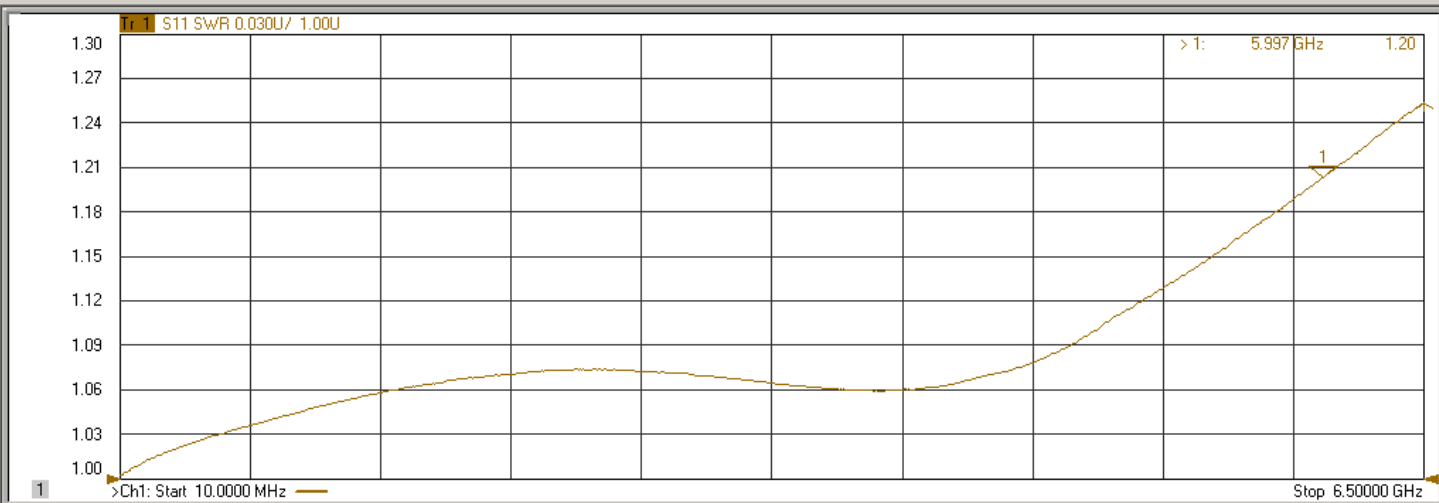
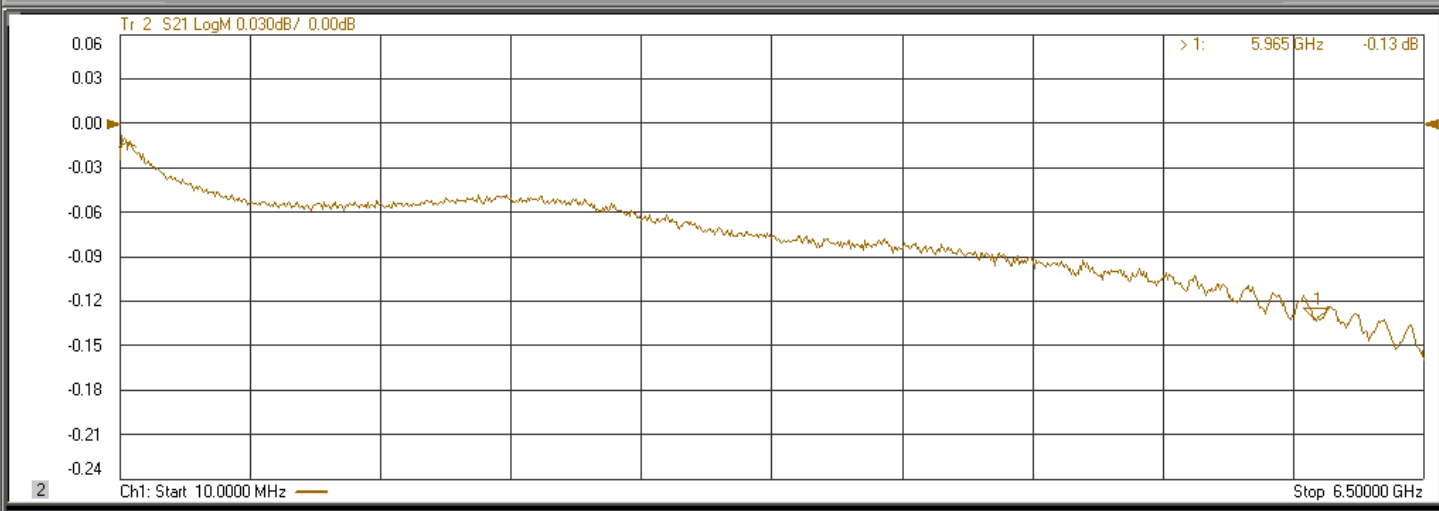
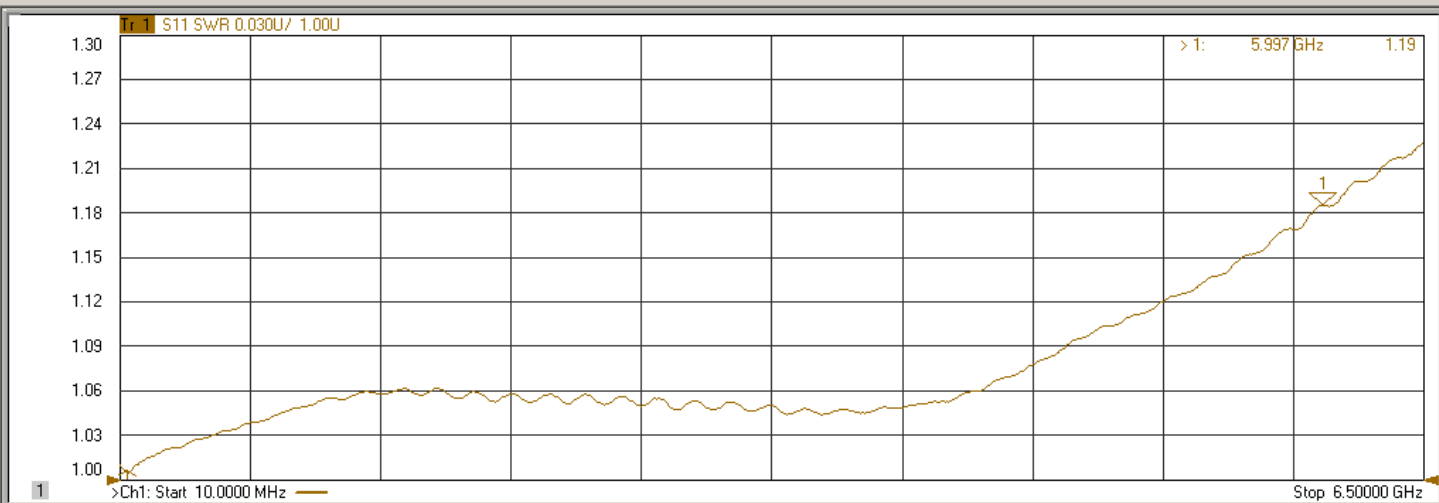

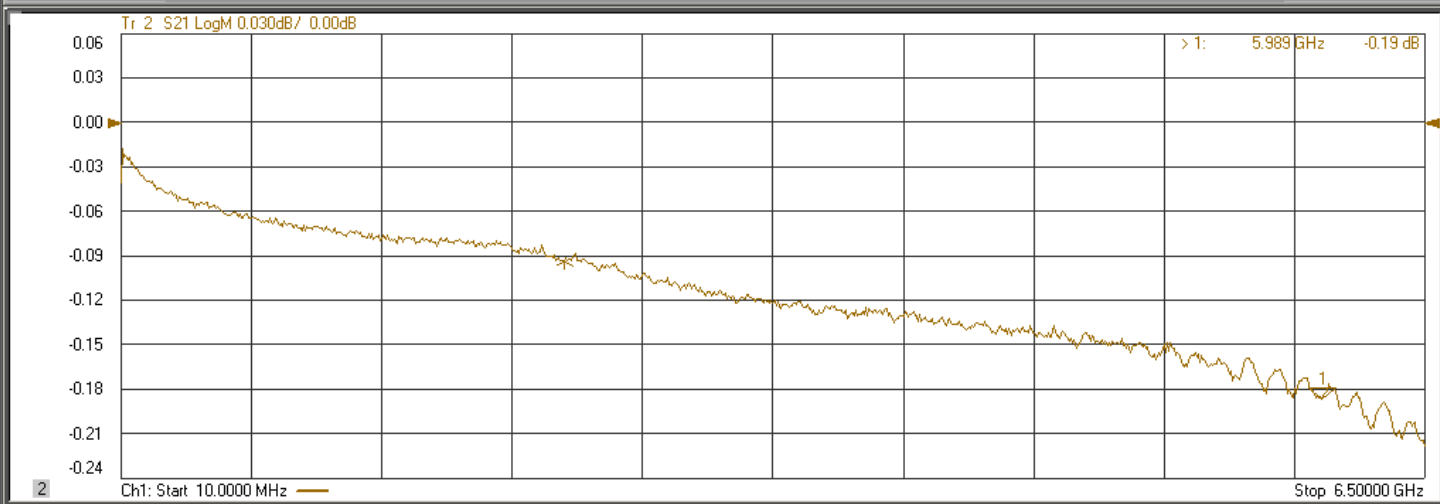
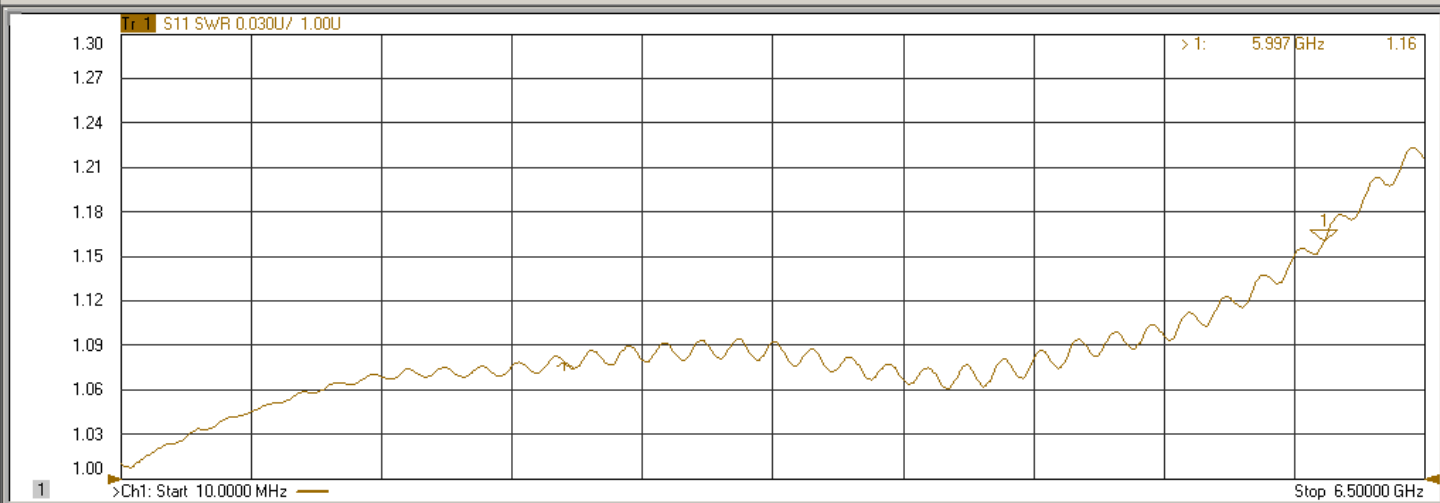
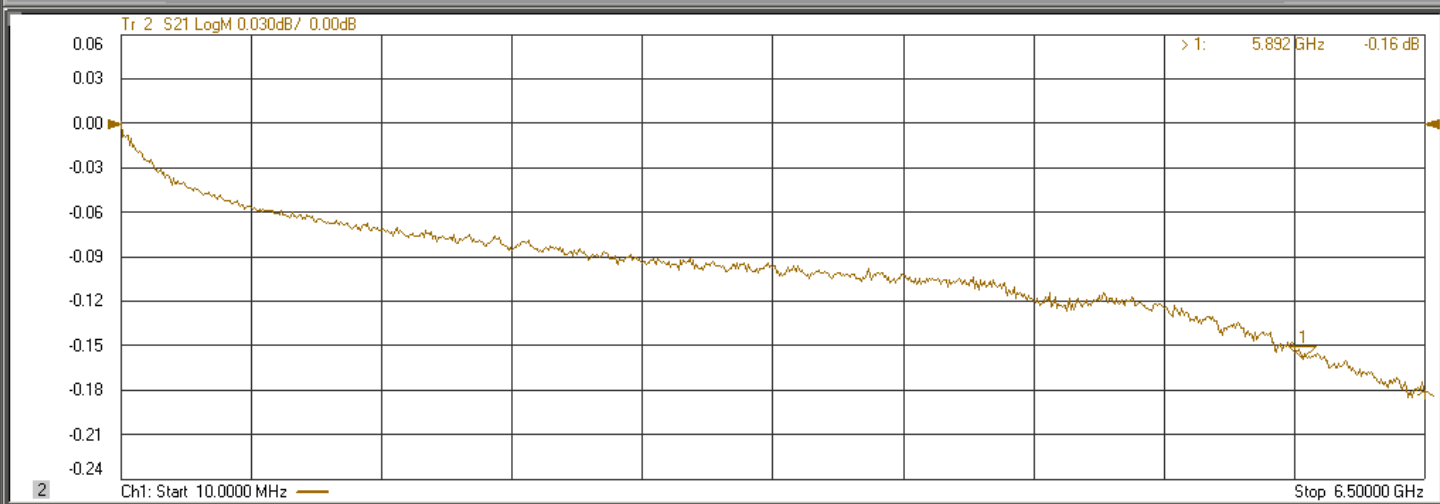
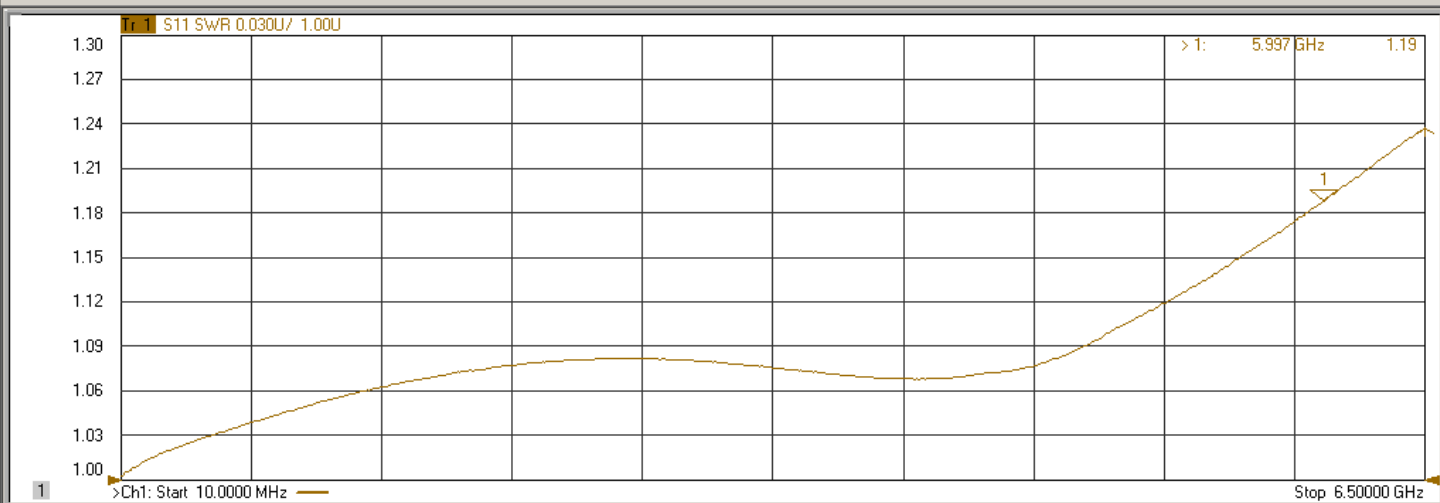

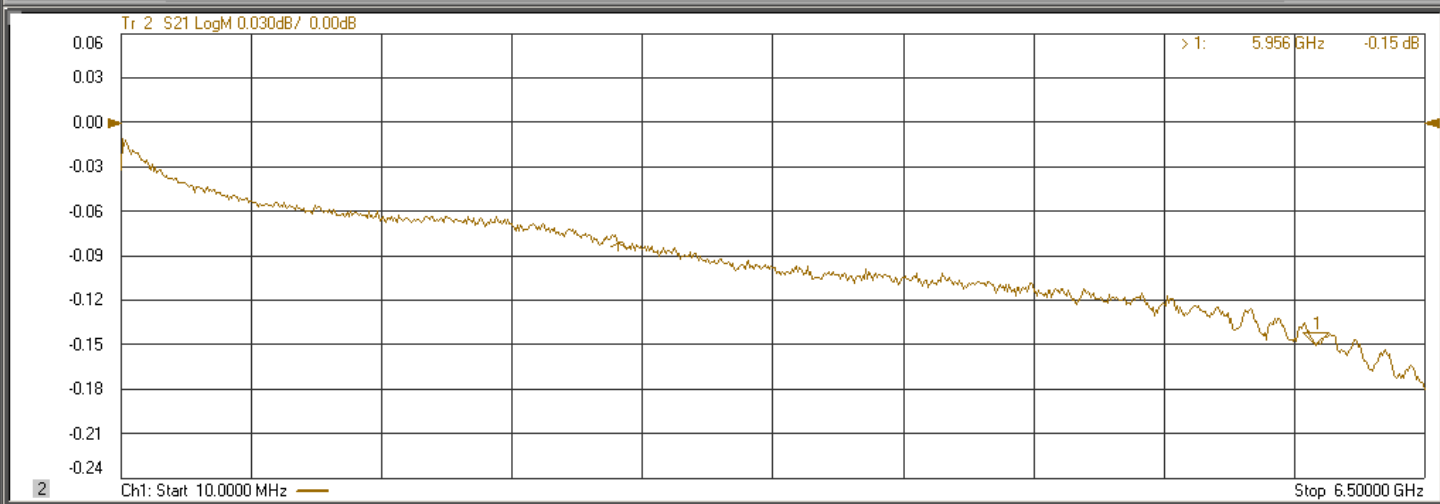
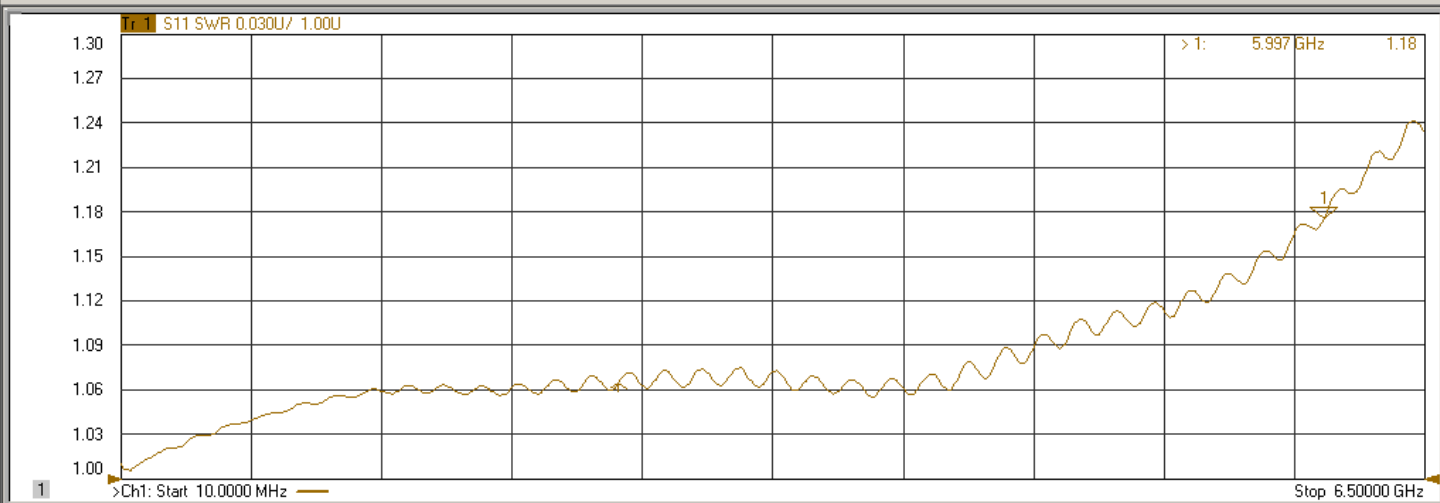
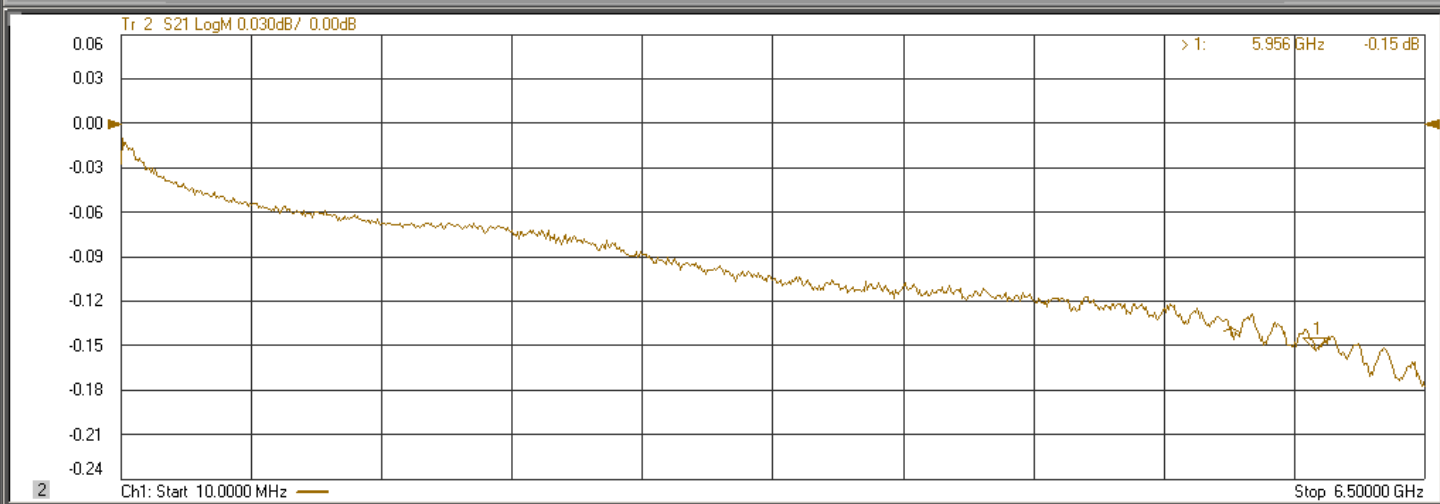
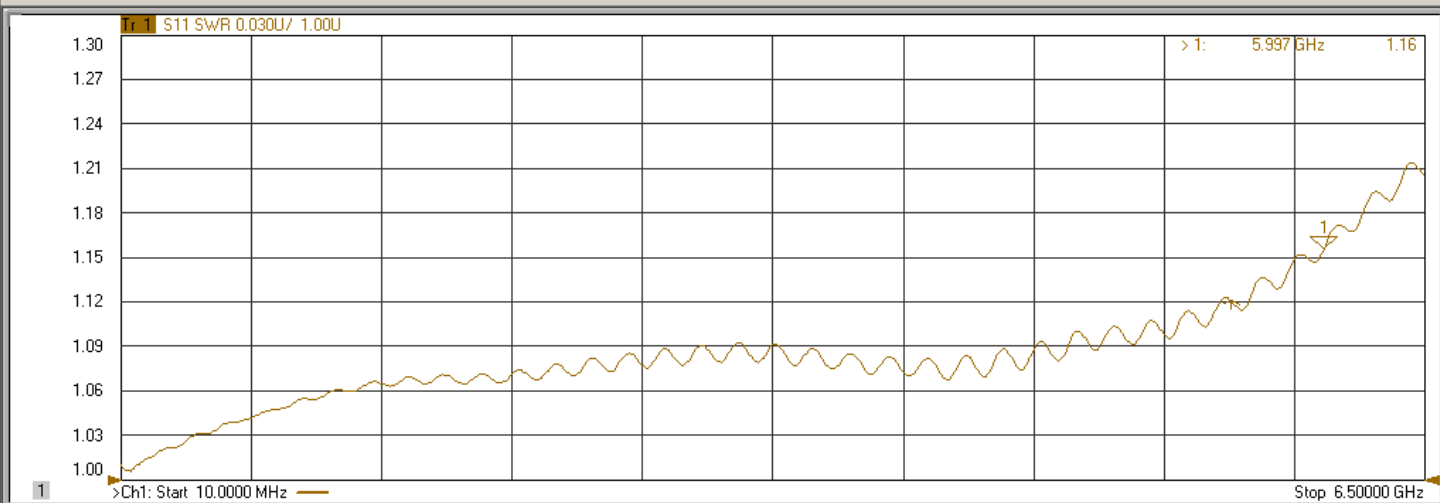

<b>Amphenol RF</b> <small>Global RF Solutions</small>	<h2 style="margin: 0;">REVISION HISTORY</h2>
--	--

Amphenol RF ASIA  
 Block DM2 Tang Wei Industrial, General CO.Gong Ming Town,  
 Bao An District, Shen Zhen City, China

	Dates:	Signatures:	
Prepared by: <b>Todd Smith</b>	January 13, 2014	<i>Todd Smith</i>	
Eng Approval: <i>Ken Capozzi</i>	January 13, 2014	<i>Ken Capozzi</i>	
NPI Approval:	January 13, 2014	<i>[Signature]</i>	

**Design Verification Test Report**

**DVT Number: 3213**  
**EAR Number: 5916**  
**Amphenol Part Number: 901-10465**  
**Product Revision: 2**  
**Part Description: SMA Jack to AMC Probe Adapter**

**DVT Revision History**

1	Initial Release	January 13, 2014

**Ship Acceptance/Approval**

	Dates	Signatures	
QA Approval: <b>Fred Silva</b>	January 13, 2014	<i>Fred Silva</i>	
Administrative Approval: <b>Greg Straiton</b>	January 13, 2014	<i>Greg Straiton</i>	