

PART NAME: KNOB SCALE: 1:1 DATE: 12/21/93 DR. BY H.S.

THIS DRAWING IS THE PROPERTY OF DAVIES MOLDING COMPANY, IS SUBMITTED SOLELY AS A DESIGN OR ENGINEERING PROJECT. WE ACCEPT NO RESPONSIBILITY WHATSOEVER FOR THE PRACTICAL APPLICATION OF THE PIECES MADE TO THIS DESIGN.



DESIGNERS & MANUFACTURERS OF KNOBS, HANDLES, CASES & CUSTOM PLASTIC COMPONENTS

P/N 3035AS

M^{NO.} 3035

CAVITY	3035
PLUNGER	3035
PLUNGER PIN	3035-A
OUTER PIN	3008-28
INNER PIN	NONE
SHIMS	1/4+1/8
INSERT	I0209

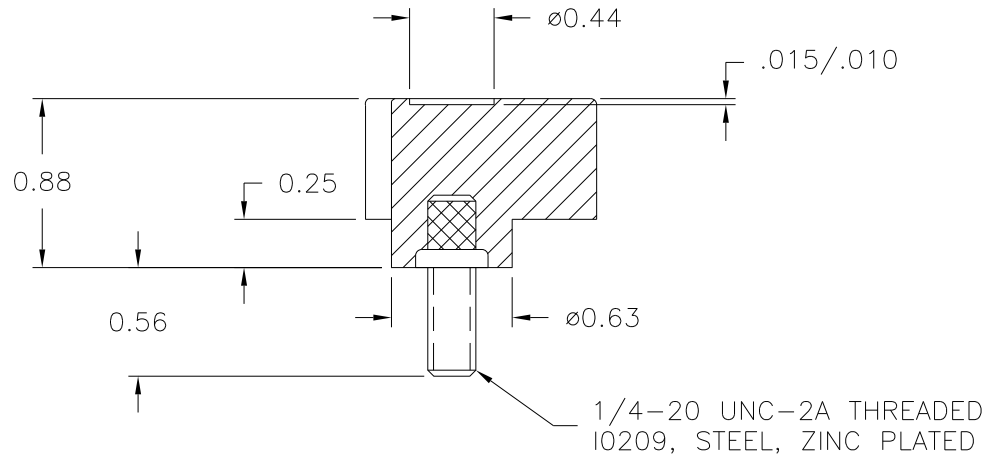
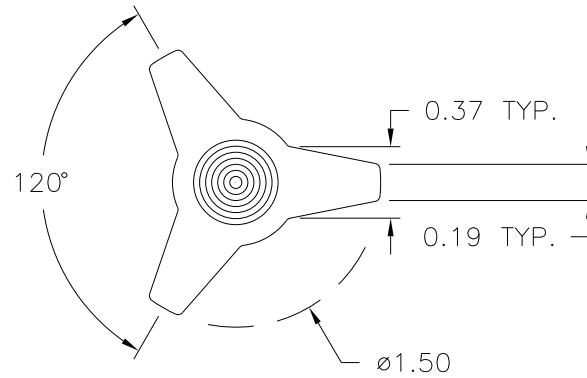

MATERIAL: G.P. PHENOLIC (B11)
COLOR: BLACK

TOLERANCES: UNLESS OTHERWISE SPECIFIED	DO NOT SCALE DRAWING	A	ADDED INNER & OUTER PINS, CORRECTED TOOLING BOX	TS	10/16/02
		-	REDRAWN	TL	11/16/99
DECIMALS: X.XXX ± .005 X.XX ± .015	MM: X.XX ± 0.15MM X.X ± 0.4MM	-	DWG. UPDATED	HD	4/30/98
		-	ALT. PINS ADDED	HD	5/14/85
FRACTIONS ± 1/64	ANG. ± 1°	CHANGES			