

QN MALE - N MALE ADAPTER

R191.757.000

Série : ADAPT

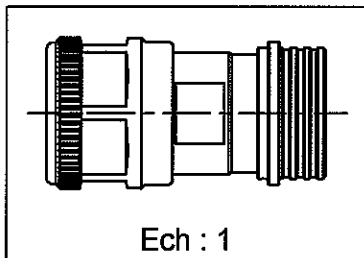
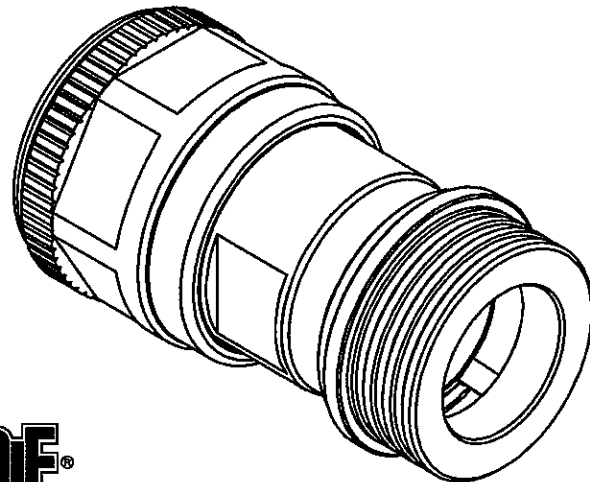
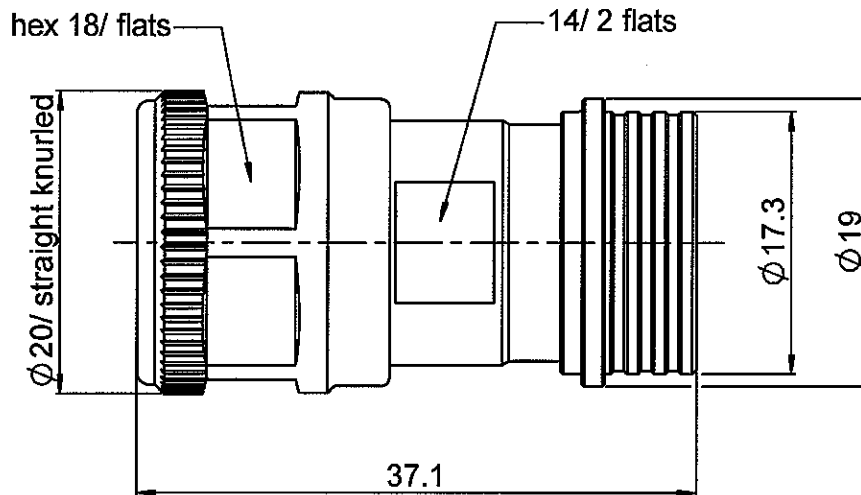

All dimensions are in mm.

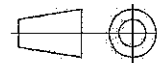

COMPONENTS	MATERIALS	PLATINGS (µm)
BODY	BRASS	BBR 0.5 OVER SILVER 3
CENTER CONTACT	BRASS	SILVER 5 PASSIVATED OVER COPPER 0.5
OUTER CONTACT	BERYLLIUM COPPER, BRASS	GOLD 0.3 OVER CHEMICAL NICKEL
INSULATOR	PTFE	
GASKET	EPDM	
OTHERS PARTS	BRASS	BBR 2
-	-	-
-	-	-

Issue : 0519 E

In the effort to improve our products, we reserve the rights to make changes judged to be necessary.



QN MALE - N MALE ADAPTER

R191.757.000

Série : ADAPT

PACKAGING

Standard	Unit	Other
1	-	Contact us

SPECIFICATION

ELECTRICAL CHARACTERISTICS

ENVIRONMENTAL

Impedance		50 Ω
Frequency		0-6* GHz
VSWR	1.05 +	0.025 x F(GHz) Maxi
Insertion loss		0.048 √F(GHz) dB Maxi
RF leakage	-(**90 - F(GHz)) dB Maxi
Voltage rating		1400 Veff Maxi
Dielectric withstanding voltage		2500 Veff mini
Insulation resistance		5000 MΩ mini

Operating	-55/+125 ° C
Hermetic seal	NA Atm.cm3/s
Panel leakage	NA

MECHANICAL CHARACTERISTICS

OTHERS CHARACTERISTICS

Center contact retention		
Axial force – Mating end		27 N mini
Axial force – Opposite end		27 N mini
Torque		NA N.cm mini
Recommended torque		
Mating	N	170 N.cm
	QN	0 N.cm
		0 N.cm
Panel nut		N.cm
Mating life		100 Cycles mini
Weight		41.200 g

* Usable 0-11GHz
 **RF Leakage : -80dB min 3<F<6GHz
 ***PIM3: -112dBm (2 x 20W at 1.8GHz)

Issue : 0519 E

In the effort to improve our products, we reserve the rights to make changes judged to be necessary.



RADIALL®