

AVERY DENNISON MARKETING SPECIFICATION

TOLERANCES IN. = ± .030 IN.
MM = ± 0.7 mm

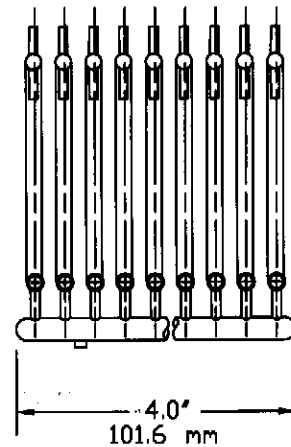
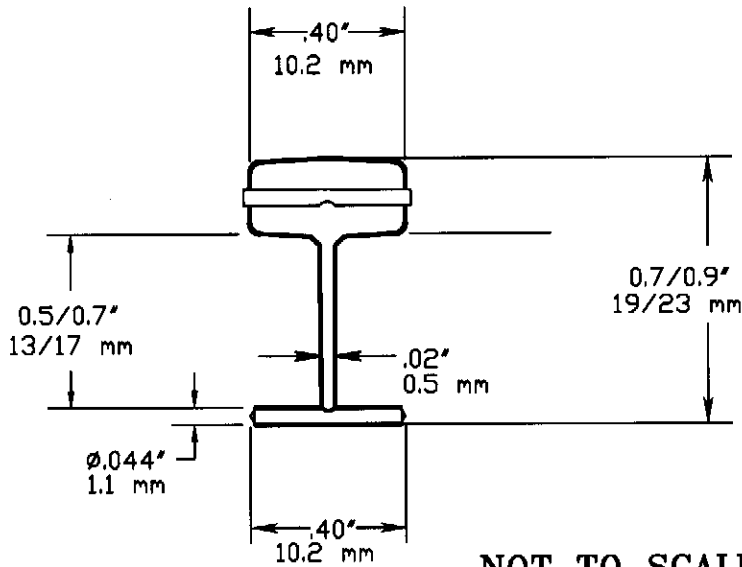

NOT TO SCALE

| | |
|---------------------------|--|
| NOMINAL TENSILE STRENGTH: | 5.0 - 7.0 LBSF / 2.3 - 3.2 KGF |
| MATERIAL: | NYLON: TYPE 6 |
| WEIGHT/FASTENER: | 0.0017 oz / .050 grams |
| CLIP QUANTITY: | 50 |
| APPLICATION TOOL: | 10651 MARK III PISTOL GRIP 08945 STANDARD SCISSOR-GRIP MARK II HAND TOOL (CONTACT LOCAL SALES PERSON FOR INFORMATION ON POWERED EQUIPMENT) |
| PACKAGED IN: | 5,000/CTN, 50,000/CASE |
| T/F CONN PADDLES | NO |

| STK.NO | DESCRIPTION |
|--------|-------------|
| 08973 | NATURAL |
| 08974 | DK.BLUE |
| 08975 | LT.BLUE |
| 08979 | ORANGE |
| 08981 | YELLOW |
| 08982 | RED |
| 08985 | BLACK |



FASTENER DIVISION
FITCHBURG, MA 01420 U.S.A.
TEL. 1-800-225-5913
FAX. 1-800-848-2169

DESCRIPTION:

1/2" (15 mm) Swiftach® HD Paddle

APPROVAL:

Edo 4h 1-12-09

SEE ABOVE

REV
H