

UNCONTROLLED DOCUMENT

PART NUMBER  
SSL-LX25783SYD

REV.  
A

REV.	E.C.N. NUMBER AND REVISION COMMENTS	DATE
A	E.C.N. #10702.	1.10.01

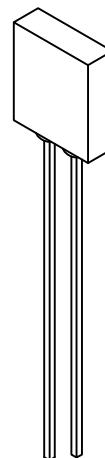
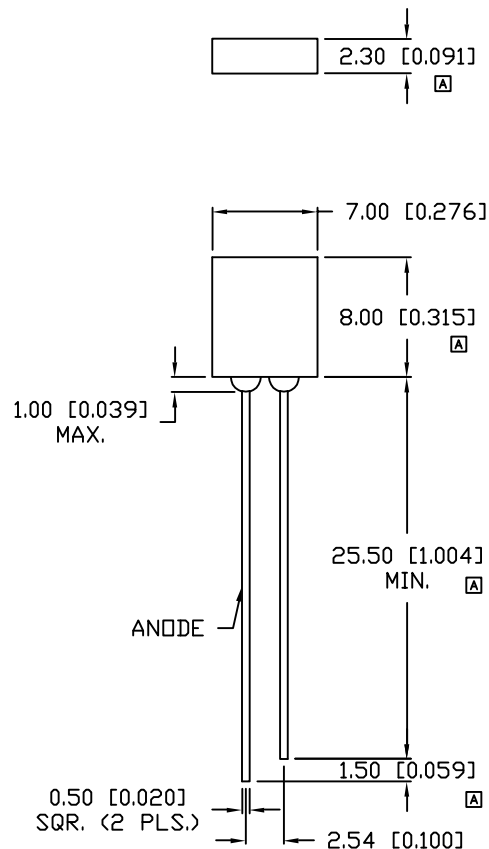

ELECTRO-OPTICAL CHARACTERISTICS  $T_A=25^{\circ}\text{C}$   $I_f=20\text{mA}$

PARAMETER	MIN	TYP	MAX	UNITS	TEST COND
PEAK WAVELENGTH		585		nm	
FORWARD VOLTAGE		2.1	2.5	$V_f$	
REVERSE VOLTAGE	5.0			$V_r$	$I_f=100\mu\text{A}$
AXIAL INTENSITY		160		mcd	$I_f=20\text{mA}$
VIEWING ANGLE		110		2x theta	
EMITTED COLOR:	YELLOW				
EPOXY LENS FINISH:	YELLOW DIFFUSED				

LIMITS OF SAFE OPERATION AT  $25^{\circ}\text{C}$

PARAMETER	MAX	UNITS
PEAK FORWARD CURRENT*	150	mA
STEADY CURRENT	30	mA
POWER DISSIPATION	110	mW
DERATE FROM $25^{\circ}\text{C}$	-1.2	mW/ $^{\circ}\text{C}$
OPERATING, STORAGE TEMP.	-55 TO +85	$^{\circ}\text{C}$
SOLDERING TEMP.	+260	$^{\circ}\text{C}$
2.0mm FROM BODY		3 SEC. MAX

\*  $t < 10\mu\text{s}$

\*UNLESS OTHERWISE SPECIFIED TOLERANCES PER DECIMAL PRECISION ARE: X= $\pm 1$  ( $\pm 0.039$ ), X.X= $\pm 0.5$  ( $\pm 0.020$ ), X.XX= $\pm 0.25$  ( $\pm 0.010$ ), X.XXX= $\pm 0.127$  ( $\pm 0.005$ ). LEAD SIZE= $\pm 0.05$  ( $\pm 0.002$ ), LEAD LENGTH= $\pm 0.75$  ( $\pm 0.030$ ). MIN= +DECIMAL PRECISION MAX.= +0.00 -DECIMAL PRECISION

UNCONTROLLED DOCUMENT

REV. A	PART NUMBER SSL-LX25783SYD
-----------	-------------------------------

2.3mm x 8mm LED, 585nm SUPER YELLOW LED,  
YELLOW DIFFUSED LENS.

**CONFIDENTIAL INFORMATION**  
THE INFORMATION CONTAINED IN THIS DOCUMENT IS THE PROPERTY OF LUMEX INC. EXCEPT AS SPECIFICALLY AUTHORIZED IN WRITING BY LUMEX INC., THE HOLDER OF THIS DOCUMENT SHALL KEEP ALL INFORMATION CONTAINED HEREIN CONFIDENTIAL AND SHALL PROTECT SAME IN WHOLE OR IN PART FROM DISCLOSURE AND DISSEMINATION TO ALL THIRD PARTIES.

**RELIABILITY NOTE**  
OUR MANY YEARS OF EXPERIENCE DATA ACCUMULATION INDICATE THAT SOLDER HEAT IS A MAJOR CAUSE OF EARLY AND FUTURE FAILURE. PLEASE PAY ATTENTION TO YOUR SOLDERING PROCESS.



290 E. HELEN ROAD  
PALATINE, IL 60067-6976  
PHONE: +1.847.359.2790  
US WEB: www.lumex.com  
TW WEB: www.lumex.com.tw

DRAWN BY: CT	CHECKED BY:	APPROVED BY:	DATE: 8.5.95
			PAGE: 1 OF 1
			SCALE: N/A