



DATA SHEET

SKY13421-486LF: 0.1 to 3.0 GHz DPxDT 2:1 Differential Switch

Applications

- GSM, DCS, PCS, CDMA, WCDMA, and TD-SCDMA differential filter switching

Features

- Broadband frequency range: 0.1 to 3.0 GHz
- Single positive voltage control: 1.3 V to 5.0 V
- Low insertion loss: 0.3 dB typical @ 1 GHz; 0.4 typical @ 2 GHz
- High isolation: 28 dB typical @ 1 GHz; 22 dB typical @ 2 GHz
- High P0.2dB
- Low phase error: 6 degrees typical @ 2 GHz
- Ultra-miniature, QFN (14-pin, 1.6 x 1.6 mm) package (MSL1, 260 °C per JEDEC J-STD-020)



Skyworks Green™ products are compliant with all applicable legislation and are halogen-free. For additional information, refer to *Skyworks Definition of Green™*, document number SQ04-0074.

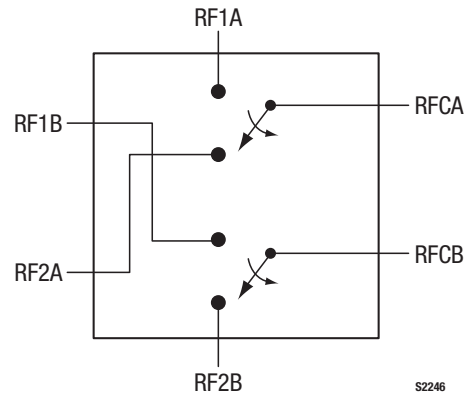

Figure 1. SKY13421-486LF Block Diagram

Description

The SKY13421-486LF is a pHEMT GaAs double-pole, double-throw (DPxDT) switch designed for cellular infrastructure band switching applications. This device is a paired DPDT switch, controlled synchronously, that includes two single-pole, double-throw (SPDT) switches with RF lines that cross inside the chip. The internal crossed switch arrangement is designed to switch balanced RF filters.

Switching is controlled by a single control voltage. Depending on the logic voltage level applied to the control pin (VCTL), the RFCA and RFCB pins are each connected to one of two switched RF outputs (RF1A, RF1B, RF2A, or RF2B) using a low insertion loss path, while maintaining a high isolation path to the alternate port. DC blocking capacitors are required on all RF ports.

The switch is manufactured in a compact, 1.6 x 1.6 mm, 14-pin exposed pad plastic Quad Flat No-Lead (QFN) package.

A functional block diagram is shown in Figure 1. The pin configuration and package are shown in Figure 2. Signal pin assignments and functional pin descriptions are provided in Table 1.

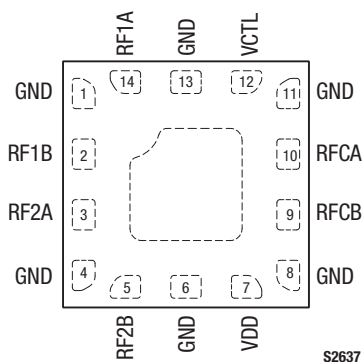

Figure 2. SKY13421-486LF Pinout – 14-Pin QFN (Top View)

Table 1. SKY13421-486LF Signal Descriptions (Note 1)

Pin	Name	Description	Pin	Name	Description
1	GND	Ground	8	GND	Ground
2	RF1B	RF port connected to RFCB and switched in tandem with RFCA/RF1A. Must be DC blocked for proper operation.	9	RFCB	RF port connected to RF1B or RF2B depending on logic supplied to the VCTL pin. Must be DC blocked for proper operation.
3	RF2A	RF port connected to RFCA. Switched in tandem with RFCB/RF2B. Must be DC blocked for proper operation.	10	RFCA	RF common connected to RF1A or RF2A depending on logic supplied to the VCTL pin. Must be DC blocked for proper operation.
4	GND	Ground	11	GND	Ground
5	RF2B	RF port connected to RFCB and switched in tandem with RFCA/RF2A. Must be DC blocked for proper operation.	12	VCTL	DC control voltage
6	GND	Ground	13	GND	Ground
7	VDD	DC supply voltage	14	RF1A	RF port connected to RFCA and switched in tandem with RFCB/RF2B. Must be DC blocked for proper operation.

Note 1: Bottom ground paddle must be connected to ground through a low impedance path.

Table 2. SKY13421-486LF Absolute Maximum Ratings (Note 1)

Parameter	Symbol	Minimum	Maximum	Units
Input power	P _{IN}		+30	dBm
Supply voltage	V _{DD}	2.0	5.5	V
Control voltage	V _{CTL}		V _{DD}	V
Storage temperature	T _{STG}	-40	+125	°C
Operating temperature	T _{OP}	-40	+85	°C

Note 1: Exposure to maximum rating conditions for extended periods may reduce device reliability. There is no damage to device with only one parameter set at the limit and all other parameters set at or below their nominal value. Exceeding any of the limits listed here may result in permanent damage to the device.

CAUTION: Although this device is designed to be as robust as possible, electrostatic discharge (ESD) can damage this device. This device must be protected at all times from ESD. Static charges may easily produce potentials of several kilovolts on the human body or equipment, which can discharge without detection. Industry-standard ESD precautions should be used at all times.

Table 3. SKY13421-486LF Recommended Operating Conditions

Parameter	Symbol	Minimum	Maximum	Units
Frequency	f	0.1	3.0	GHz
Control voltage:				
Low	V _{CTL_L}	0	30% of V _{DD}	V
High	V _{CTL_H}	55% of V _{DD}	V _{DD}	V

Functional Description

The SKY13421-486LF is comprised of a CMOS decoder that enables a differential input signal to be switched between two different differential outputs. This is particularly useful when switching between two Surface Acoustic Wave (SAW) filters.

The recommended startup sequence is:

Step 1: Apply V_{DD}

Step 2: Apply control voltage (V_{CTL})

Step 3: Apply RF input

The device must be turned off in the reverse order. The part can not have V_{CTL} high without V_{DD} applied.

Electrical and Mechanical Specifications

The absolute maximum ratings of the SKY13421-486LF are provided in Table 2. The recommended operating conditions are specified in Table 3 and electrical specifications are provided in Table 4.

Typical performance characteristics of the SKY13421-486LF are illustrated in Figures 3 through 8.

The state of the SKY13421-486LF is determined by the logic provided in Table 5.

Table 4. SKY13421-486LF Electrical Specifications (Note 1)
(V_{DD} = 2.7 V, V_{CTL} = 1.8 V, T_{OP} = +25 °C, P_{IN} = 0 dBm, Characteristic Impedance [Z₀] = 50 Ω, Unless Otherwise Noted)

Parameter	Symbol	Test Condition	Min	Typical	Max	Units
RF Specifications						
Insertion loss	IL	RFCA to RF1A/2A, RFCB to RF1B/2B:				
		0.1-1.0 GHz		0.30	0.45	dB
		1.0-2.0 GHz		0.40	0.55	dB
		2.0-2.5 GHz		0.45	0.60	dB
Isolation	Iso	RFCA to RF1A/2A, RFCB to RF1B/2B:				
		0.1-1.0 GHz	26	28		dB
		1.0-2.0 GHz	20	22		dB
		2.0-2.5 GHz	18	20		dB
Return loss	S ₁₁	0.1-2.5 GHz	15	22		dB
Phase error	PE	f = 2 GHz, between "on" paths		6		deg
0.2 dB Compression Point	P _{0.2dB}	0.1-2.5 GHz	+20	+24		dBm
3 rd Order Input Intercept Point	IIP ₃	0.1-2.5 GHz, Δf = 1 MHz, P _{IN} = +15 dBm/tone		+55		dBm
Switching speed		50% V _{CTL} to 90/10% RF, 90/10% RF or 10/90% RF		75		ns
				50		ns
DC Specifications						
Supply voltage	V _{DD}		2.0		5.5	V
Control voltage:	V _{CTL_L} V _{CTL_H}		0		30% of V _{DD}	V
			55% of V _{DD}		V _{DD}	V
Supply current				2	10	μA
Control current	I _{DD}			5		μA

Note 1: Performance is guaranteed only under the conditions listed in this table.

Typical Performance Characteristics

(VDD = 2.7 V, VCTL = 1.8 V, TOP = +25 °C, PIN = 0 dBm, Characteristic Impedance [Zo] = 50 Ω, Unless Otherwise Noted)

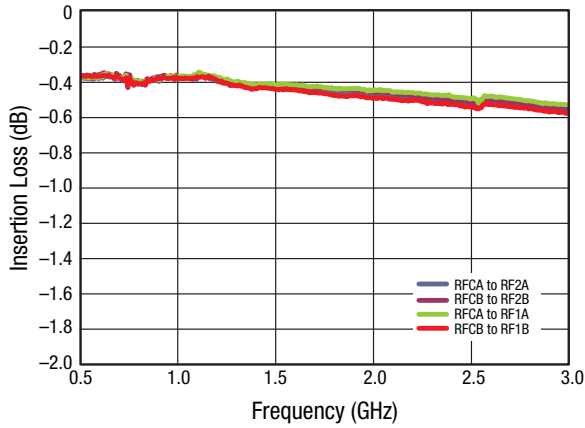

Figure 3. Insertion Loss vs Frequency

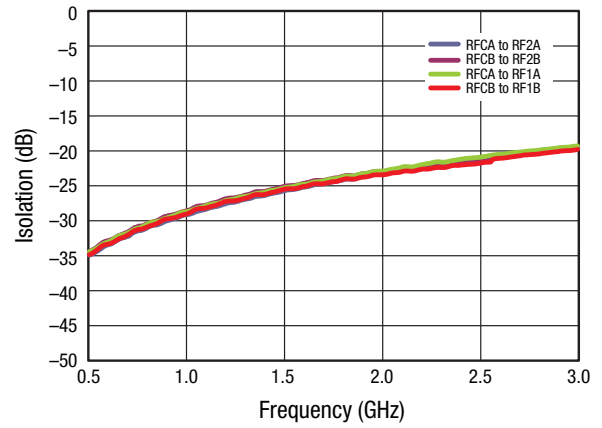

Figure 4. Isolation vs Frequency

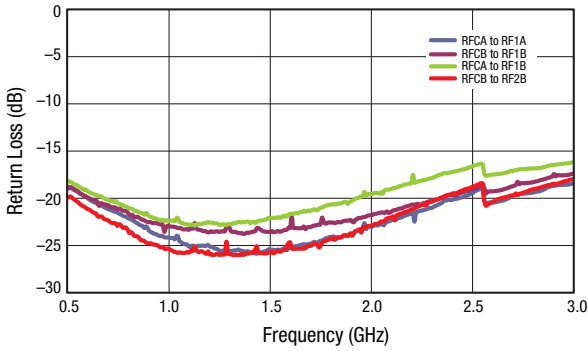

Figure 5. Return Loss vs Frequency

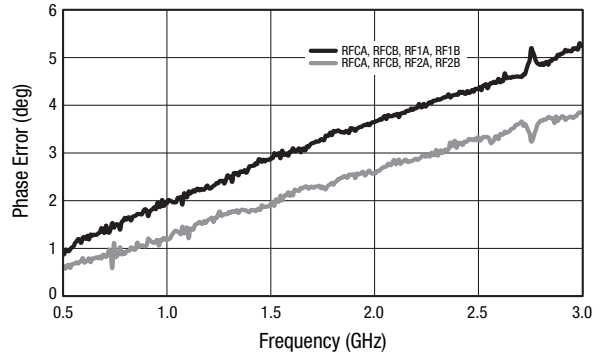

Figure 6. Phase Error vs Frequency

Table 5. SKY13421-486LF Truth Table

VCTL (Pin 12)	Insertion Loss Paths
1	RFCA to RF1A RFCB to RF1B
0	RFCA to RF2A RFCB to RF2B

Note: "1" = 55% of VDD to VDD. "0" = 30% of VDD. Any state other than described in this table places the switch into an undefined state. An undefined state will not damage the device. VDD = 2 to 5 V and must be supplied before the VCTL signal is pushed high.

Evaluation Board Description

The SKY13421-486LF Evaluation Board is used to test the performance of the SKY13421-486LF DPxDT Switch. An Evaluation Board schematic diagram is provided in Figure 7. An assembly drawing for the Evaluation Board is shown in Figure 8.

Package Dimensions

The PCB layout footprint for the SKY13421-486LF is provided in Figure 9. Typical case markings are shown in Figure 10. Package dimensions for the 14-pin QFN are shown in Figure 11, and tape and reel dimensions are provided in Figure 12.

Package and Handling Information

Instructions on the shipping container label regarding exposure to moisture after the container seal is broken must be followed. Otherwise, problems related to moisture absorption may occur when the part is subjected to high temperature during solder assembly.

The SKY13421-486LF is rated to Moisture Sensitivity Level 1 (MSL1) at 260 °C. It can be used for lead or lead-free soldering. For additional information, refer to the Skyworks Application Note, *Solder Reflow Information*, document number 200164.

Care must be taken when attaching this product, whether it is done manually or in a production solder reflow environment. Production quantities of this product are shipped in a standard tape and reel format.

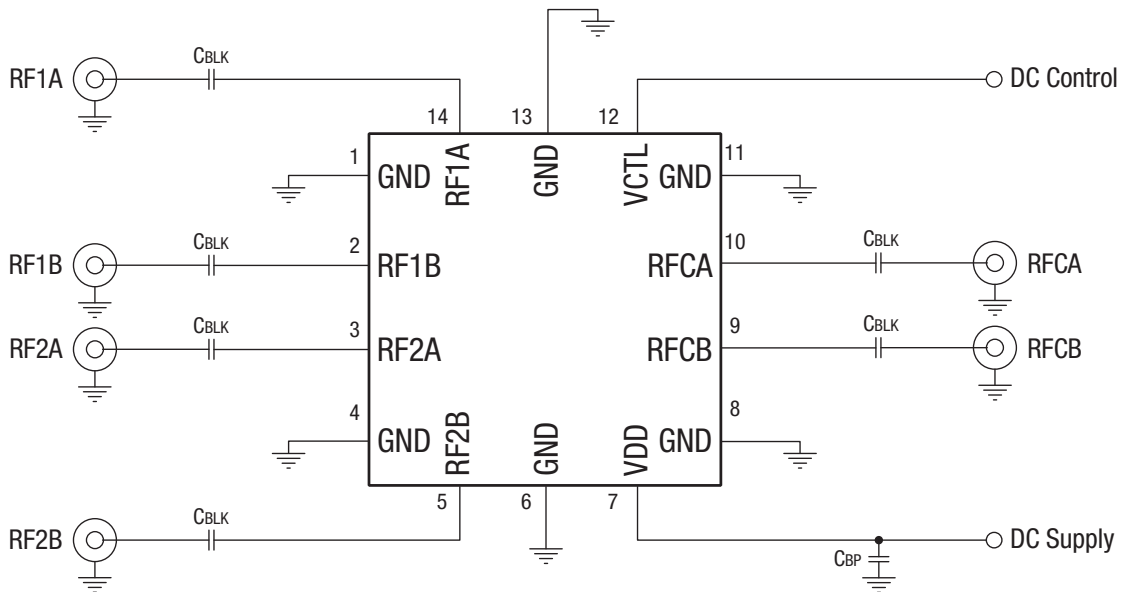

S2638

Figure 7. SKY13421-486LF Evaluation Board Schematic

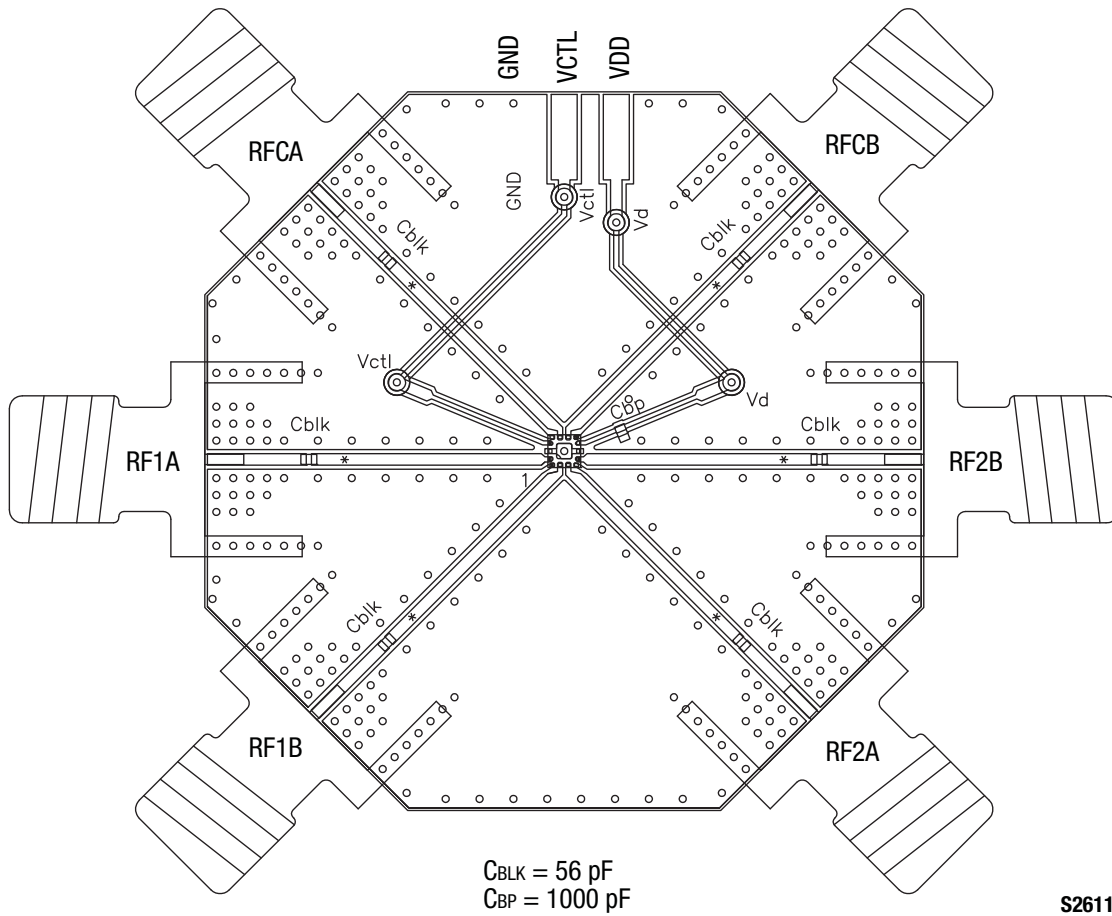
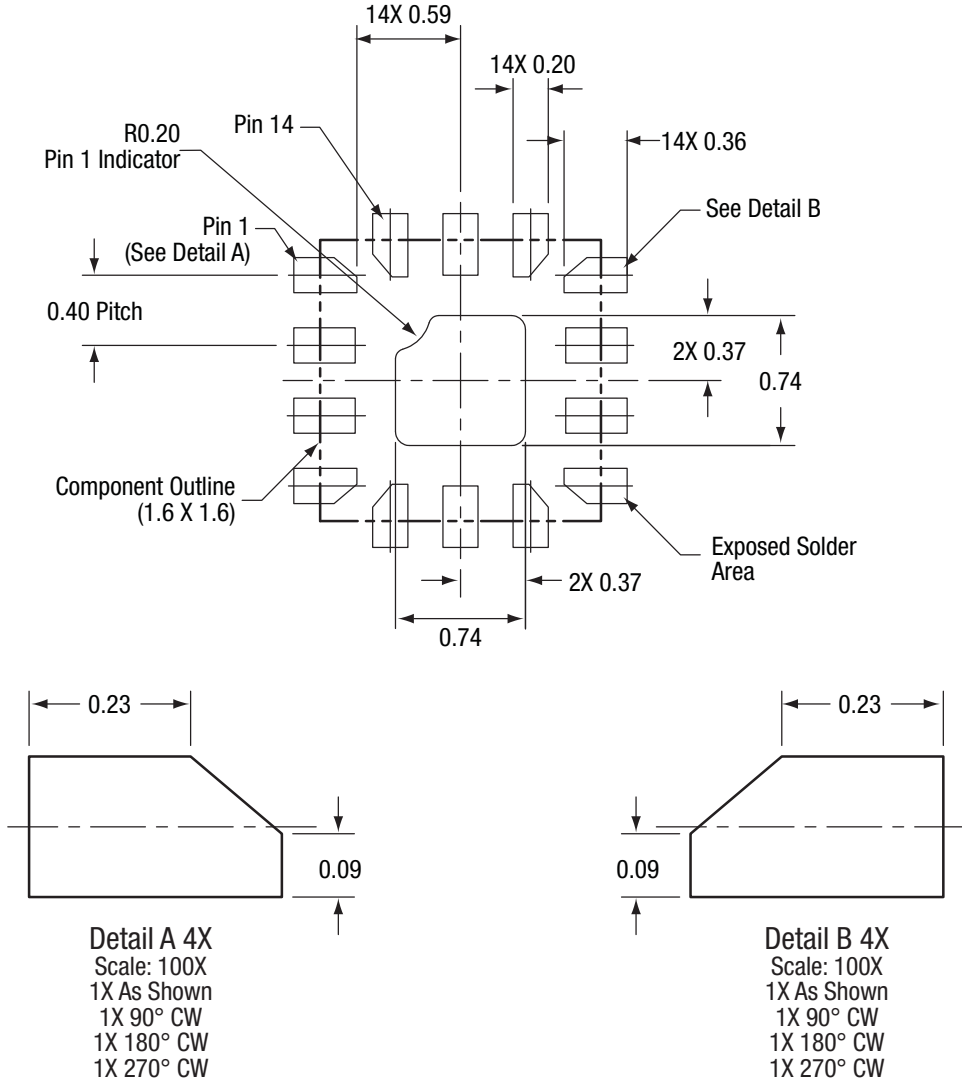

Figure 8. SKY13421-486LF Evaluation Board Assembly Diagram

S2611



All measurements in millimeters

S3541

Figure 9. SKY13421-486LF PCB Layout Footprint (Top View)

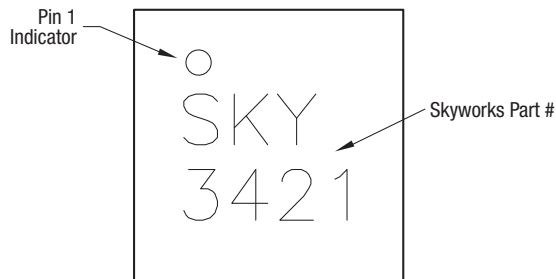
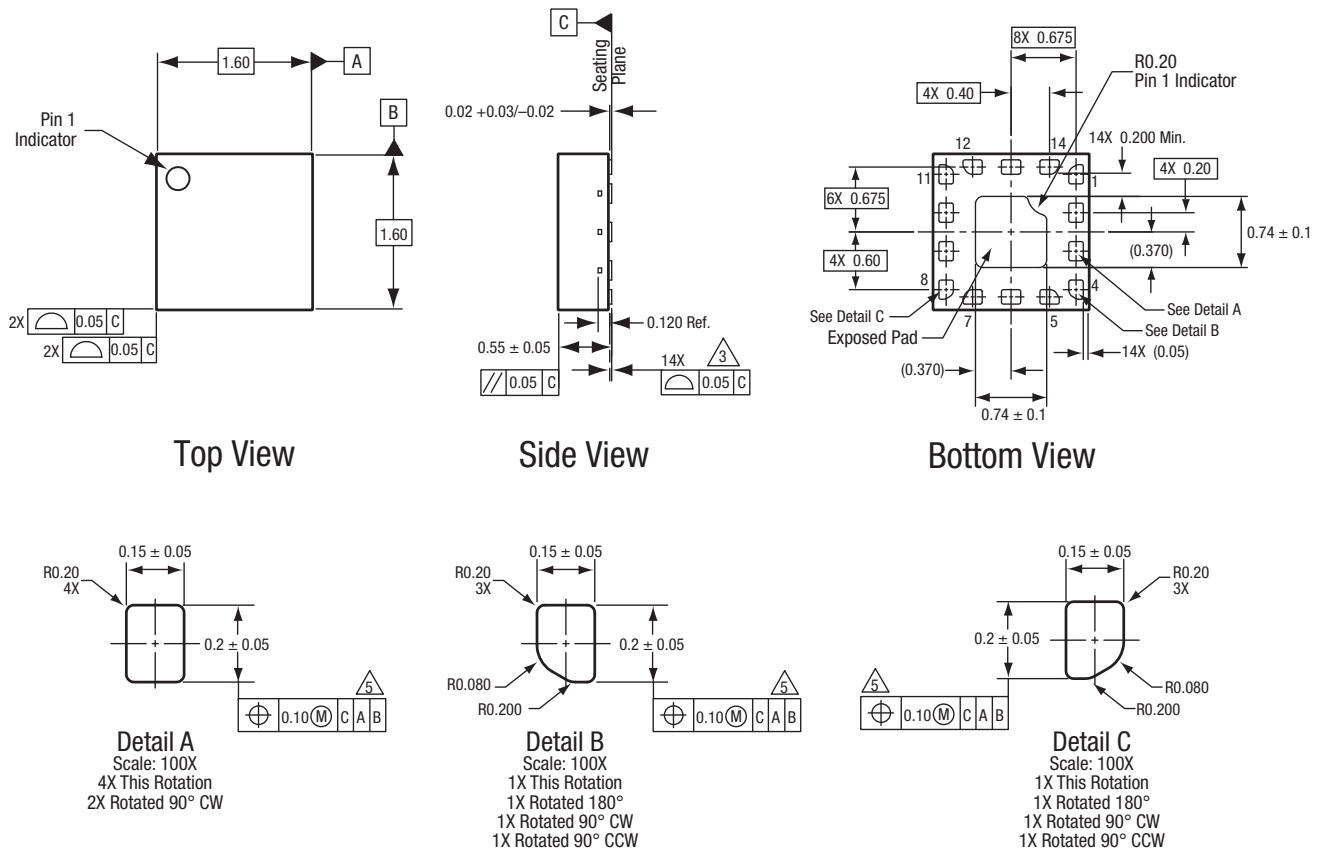

Figure 10. Typical Case Markings (Top View)



All measurements are in millimeters.
 Dimensioning and tolerancing according to ASME Y14.5M-1994.
 Coplanarity applies to the terminals and all other bottom surface metalization.
 Plating requirement per source control drawing (SCD) 2504.
 Dimension applies to metalized terminal. If the terminal has a radius on its end,
 the width dimension should not be measured in that radius area.

S2636

Figure 11. SKY13421-486LF 14-Pin QFN Package Dimensions

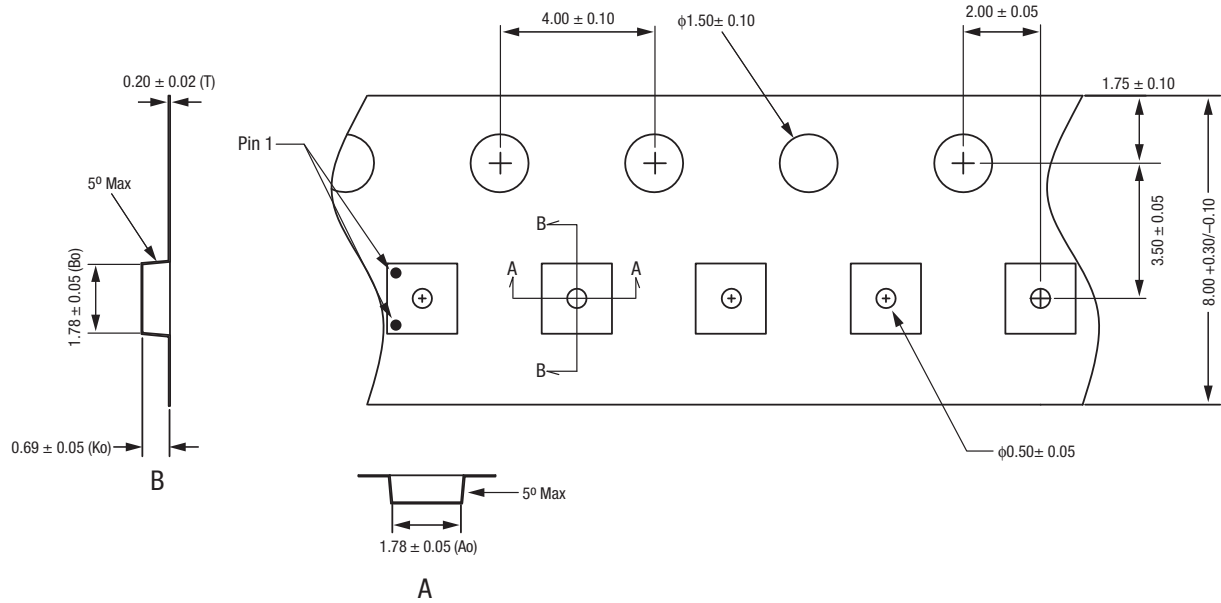

Notes:

1. Carrier tape: black conductive polycarbonate.
2. Cover tape material: transparent conductive PSA.
3. Cover tape size: 5.4 mm width.
4. All measurements are in millimeters.
5. ESD surface resistivity is $\leq 1 \times 10^8$ Ohms/square per EIA, JEDEC tape and reel specification.
6. Pin 1 orientation is in lower left corner for SOT-666 packages.
Pin 1 orientation is in upper left corner for 1.5 x 1.5 mm MLPD, QFN, and DFN packages.

S1382

Figure 12. SKY13421-486LF Tape and Reel Dimensions

Ordering Information

Model Name	Manufacturing Part Number	Evaluation Board Part Number
SKY13421-486LF: 0.1 to 3.0 GHz DPxDT 2:1 Differential Switch	SKY13421-486LF	SKY13421-486LF-EVB

Copyright © 2011, 2013-2014 Skyworks Solutions, Inc. All Rights Reserved.

Information in this document is provided in connection with Skyworks Solutions, Inc. ("Skyworks") products or services. These materials, including the information contained herein, are provided by Skyworks as a service to its customers and may be used for informational purposes only by the customer. Skyworks assumes no responsibility for errors or omissions in these materials or the information contained herein. Skyworks may change its documentation, products, services, specifications or product descriptions at any time, without notice. Skyworks makes no commitment to update the materials or information and shall have no responsibility whatsoever for conflicts, incompatibilities, or other difficulties arising from any future changes.

No license, whether express, implied, by estoppel or otherwise, is granted to any intellectual property rights by this document. Skyworks assumes no liability for any materials, products or information provided hereunder, including the sale, distribution, reproduction or use of Skyworks products, information or materials, except as may be provided in Skyworks Terms and Conditions of Sale.

THE MATERIALS, PRODUCTS AND INFORMATION ARE PROVIDED "AS IS" WITHOUT WARRANTY OF ANY KIND, WHETHER EXPRESS, IMPLIED, STATUTORY, OR OTHERWISE, INCLUDING FITNESS FOR A PARTICULAR PURPOSE OR USE, MERCHANTABILITY, PERFORMANCE, QUALITY OR NON-INFRINGEMENT OF ANY INTELLECTUAL PROPERTY RIGHT; ALL SUCH WARRANTIES ARE HEREBY EXPRESSLY DISCLAIMED. SKYWORKS DOES NOT WARRANT THE ACCURACY OR COMPLETENESS OF THE INFORMATION, TEXT, GRAPHICS OR OTHER ITEMS CONTAINED WITHIN THESE MATERIALS. SKYWORKS SHALL NOT BE LIABLE FOR ANY DAMAGES, INCLUDING BUT NOT LIMITED TO ANY SPECIAL, INDIRECT, INCIDENTAL, STATUTORY, OR CONSEQUENTIAL DAMAGES, INCLUDING WITHOUT LIMITATION, LOST REVENUES OR LOST PROFITS THAT MAY RESULT FROM THE USE OF THE MATERIALS OR INFORMATION, WHETHER OR NOT THE RECIPIENT OF MATERIALS HAS BEEN ADVISED OF THE POSSIBILITY OF SUCH DAMAGE.

Skyworks products are not intended for use in medical, lifesaving or life-sustaining applications, or other equipment in which the failure of the Skyworks products could lead to personal injury, death, physical or environmental damage. Skyworks customers using or selling Skyworks products for use in such applications do so at their own risk and agree to fully indemnify Skyworks for any damages resulting from such improper use or sale.

Customers are responsible for their products and applications using Skyworks products, which may deviate from published specifications as a result of design defects, errors, or operation of products outside of published parameters or design specifications. Customers should include design and operating safeguards to minimize these and other risks. Skyworks assumes no liability for applications assistance, customer product design, or damage to any equipment resulting from the use of Skyworks products outside of stated published specifications or parameters.

Skyworks and the Skyworks symbol are trademarks or registered trademarks of Skyworks Solutions, Inc., in the United States and other countries. Third-party brands and names are for identification purposes only, and are the property of their respective owners. Additional information, including relevant terms and conditions, posted at www.skyworksinc.com, are incorporated by reference.