

### FEATURES

**140 MHz to 1000 MHz operating frequency**  
**+2.5 dBm P1dB @ 800 MHz**  
**-155 dBm/Hz noise floor**  
**0.5 degree RMS phase error (IS95)**  
**0.2 dB amplitude balance**  
**Single 2.7 V to 5.5 V supply**  
**Pin-compatible with AD8346 and AD8349**  
**16-lead TSSOP\_EP package**

### APPLICATIONS

**Cellular communication systems**  
**W-CDMA/CDMA/GSM/PCS/ISM transceivers**  
**Fixed broadband access systems LMDS/MMDS**  
**Wireless LAN**  
**Wireless local loop**  
**Digital TV/CATV modulators**  
**Single sideband upconverter**

### PRODUCT DESCRIPTION

The AD8345 is a silicon RFIC quadrature modulator, designed for use from 140 MHz to 1000 MHz. Its excellent phase accuracy and amplitude balance enable the high performance direct modulation of an IF carrier.

The AD8345 accurately splits the external LO signal into two quadrature components through the polyphase phase splitter network. The I and Q LO components are mixed with the baseband I and Q differential input signals. Finally, the outputs of the two mixers are combined in the output stage to provide a single-ended 50  $\Omega$  drive at VOUT.

### FUNCTIONAL BLOCK DIAGRAM



Figure 1.

### APPLICATIONS

The AD8345 modulator can be used as the IF transmit modulator in digital communication systems such as GSM and PCS transceivers. It can also directly modulate an LO signal to produce QPSK and various QAM formats for 900 MHz communication systems as well as digital TV and CATV systems.

Additionally, this quadrature modulator can be used with direct digital synthesizers in hybrid phase-locked loops to generate signals over a wide frequency range with millihertz resolution.

The AD8345 modulator is supplied in a 16-lead TSSOP\_EP package. Its performance is specified over a  $-40^{\circ}\text{C}$  to  $+85^{\circ}\text{C}$  temperature range. This device is fabricated on Analog Devices' advanced silicon bipolar process.

#### Rev. B

Information furnished by Analog Devices is believed to be accurate and reliable. However, no responsibility is assumed by Analog Devices for its use, nor for any infringements of patents or other rights of third parties that may result from its use. Specifications subject to change without notice. No license is granted by implication or otherwise under any patent or patent rights of Analog Devices. Trademarks and registered trademarks are the property of their respective owners.

## TABLE OF CONTENTS

Features .....	1	Basic Connections .....	12
Applications.....	1	LO Drive.....	12
Functional Block Diagram .....	1	LO Frequency Range .....	12
Product Description.....	1	Baseband I and Q Channel Drive .....	13
Applications.....	1	Reduction of LO Leakage.....	13
Revision History .....	2	Single-Ended I and Q Drive.....	13
Specifications.....	3	RF Output.....	14
Absolute Maximum Ratings.....	4	Application with TxDAC® .....	14
ESD Caution.....	4	Soldering Information .....	15
Pin Configuration and Function Descriptions.....	5	Evaluation Board.....	15
Typical Performance Characteristics .....	6	Characterization Setups.....	17
Equivalent Circuits .....	10	SSB Setup .....	17
Circuit Description.....	11	Modulated Waveform Setup .....	18
Overview.....	11	CDMA IS95.....	18
LO Interface.....	11	WCDMA 3GPP .....	18
Differential Voltage-to-Current Converter.....	11	GSM .....	18
Mixers .....	11	Outline Dimensions .....	19
Differential-to-Single-Ended Converter .....	11	Ordering Guide .....	19
Bias .....	11		

## REVISION HISTORY

### 12/05—Rev. A to Rev. B

Updated Format.....	Universal
Changes to Ordering Guide .....	19

### 4/05—Rev. 0 to Rev. A

Updated Format.....	Universal
Change to Part Name .....	Universal
Updated Outline Dimensions .....	19
Changes to Ordering Guide .....	19

### 7/01—Revision 0: Initial Version

## SPECIFICATIONS

$V_S = 5\text{ V}$ ; LO =  $-2\text{ dBm}$  @ 800 MHz;  $50\ \Omega$  source and load impedances; I and Q inputs  $0.7\text{ V} \pm 0.3\text{ V}$  on each side for a  $1.2\text{ V}$  p-p differential input, I and Q inputs driven in quadrature @ 1 MHz baseband frequency.  $T_A = 25^\circ\text{C}$ , unless otherwise noted.

**Table 1.**

Parameter	Min	Typ	Max	Unit	Test Conditions/Comments
<b>RF OUTPUT</b>					
Operating Frequency <sup>1</sup>	140		1000	MHz	
Output Power		0.5		dBm	140 MHz
		0.5		dBm	220 MHz
	-3	-1	+2	dBm	800 MHz
Output P1dB		2.5		dBm	
Noise Floor		-155		dBm/Hz	20 MHz offset from LO, all BB inputs at 0.7 V
Quadrature Error		0.5		Degree rms	CDMA IS95 setup (see Figure 38)
I/Q Amplitude Balance		0.2		dB	CDMA IS95 setup (see Figure 38)
LO Leakage		-41		dBm	140 MHz
		-40		dBm	220 MHz
		-42	-33	dBm	800 MHz
Sideband Rejection		-33		dBc	140 MHz
		-48	-40	dBc	220 MHz
		-42	-34	dBc	800 MHz
Third Order Distortion		-52		dBc	
Second Order Distortion		-60		dBc	
Equivalent Output IP3		25		dBm	
Equivalent Output IP2		59		dBm	
Output Return Loss (S22)		-20		dB	
<b>RESPONSE TO CDMA IS95</b>					See Figure 38
<b>BASEBAND SIGNALS</b>					
ACPR		-72		dBc	
EVM		1.3		%	
Rho		0.9995			
<b>LO INPUT</b>					
LO Drive level	-10	-2	0	dBm	
LOIP Input Return Loss (S11) <sup>2</sup>		-5		dB	No termination on LOIP, LOIN at ac ground
		-9		dB	50 $\Omega$ terminating resistor, differential drive via balun
<b>BASEBAND INPUTS</b>					
Input Bias Current		10		$\mu\text{A}$	
Input Capacitance		2		pF	
DC Common Level	0.6	0.7	0.8	V	
Bandwidth (3 dB)		80		MHz	Full power ( $0.7\text{ V} \pm 0.3\text{ V}$ on each input, see Figure 4)
<b>ENABLE</b>					
Turn-On		2.5		$\mu\text{s}$	Enable high to output within 0.5 dB of final value
Turn-Off		1.5		$\mu\text{s}$	Enable low to supply current dropping below 2 mA
ENBL High Threshold (Logic 1)		$+V_S/2$		V	
ENBL Low Threshold (Logic 0)		$+V_S/2$		V	
<b>POWER SUPPLIES</b>					
Voltage	2.7		5.5	V	
Current Active	50	65	78	mA	
Current Standby		70		$\mu\text{A}$	

<sup>1</sup> For information on operation below 140 MHz, see Figure 29.

<sup>2</sup> See the LO Interface section for more details on input matching.

## ABSOLUTE MAXIMUM RATINGS

Table 2.

Parameter	Rating
Supply Voltage VPS1, VPS2	5.5 V
Input Power LOIP, LOIN (re 50 $\Omega$ )	10 dBm
IBBP, IBBN, QBBP, QBBN	0 V, 2.5 V
Internal Power Dissipation	500 mW
$\theta_{JA}$ (Exposed Paddle Soldered Down)	30°C/W
$\theta_{JA}$ (Exposed Paddle not Soldered Down)	95°C/W
Maximum Junction Temperature	150°C
Operating Temperature Range	-40°C to +85°C
Storage Temperature Range	-65°C to +150°C
Lead Temperature Range (Soldering 60 sec)	300°C

Stresses above those listed under Absolute Maximum Ratings may cause permanent damage to the device. This is a stress rating only; functional operation of the device at these or any other conditions above those indicated in the operational section of this specification is not implied. Exposure to absolute maximum rating conditions for extended periods may affect device reliability.

### ESD CAUTION

ESD (electrostatic discharge) sensitive device. Electrostatic charges as high as 4000 V readily accumulate on the human body and test equipment and can discharge without detection. Although this product features proprietary ESD protection circuitry, permanent damage may occur on devices subjected to high energy electrostatic discharges. Therefore, proper ESD precautions are recommended to avoid performance degradation or loss of functionality.



## PIN CONFIGURATION AND FUNCTION DESCRIPTIONS



Figure 2. Pin Configuration

Table 3. Pin Function Descriptions

Pin No.	Mnemonic	Description	Equivalent Circuit
1, 2	IBBP, IBBN	I Channel Baseband Differential Input Pins. These high impedance inputs should be dc-biased to approximately 0.7 V. Nominal characterized ac swing is 0.6 V p-p on each pin (0.4 V to 1 V). This gives a differential drive of 1.2 V p-p. Inputs are not self-biasing, so external biasing circuitry must be used in ac-coupled applications.	Circuit A
3, 9, 13, 14	COM3	Ground Pin for Input V-to-I Converters and Mixer Core.	
4	COM1	Ground Pin for the LO Phase Splitter and LO Buffers.	
5, 6	LOIN, LOIP	Differential LO Drive Pins. Internal dc bias (approximately 1.8 V @ $V_S = 5$ V) is supplied. Pins must be ac-coupled. Single-ended or differential drive is permissible.	Circuit B
7	VPS1	Power Supply Pin for the Bias Cell and LO Buffers. This pin should be decoupled using local 1000 pF and 0.01 $\mu$ F capacitors.	
8	ENBL	Enable Pin. A high level enables the device; a low level puts the device in sleep mode.	Circuit C
10	COM2	Ground Pin for the Output Stage of Output Amplifier.	
11	VOUT	50 $\Omega$ DC-Coupled RF Output. Pin should be ac-coupled.	Circuit D
12	VPS2	Power Supply Pin for Baseband Input Voltage to Current Converters and Mixer Core. This pin should be decoupled using local 1000 pF and 0.01 $\mu$ F capacitors.	
15, 16	QBPN, QBBP	Q Channel Baseband Differential Input Pins. Inputs should be dc-biased to approximately 0.7 V. Nominal characterized ac swing is 0.6 V p-p on each pin (0.4 V to 1 V). This gives a differential drive level of 1.2 V p-p. Inputs are not self-biasing, so external biasing circuitry must be used in ac-coupled applications.	Circuit A

TYPICAL PERFORMANCE CHARACTERISTICS



Figure 3. Single Sideband (SSB) Output Power ( $P_{OUT}$ ) vs. LO Frequency ( $F_{LO}$ ) ( $I$  and  $Q$  Inputs Driven in Quadrature at Baseband Frequency ( $F_{BB}$ ) = 1 MHz;  $T_A$  = 25°C)



Figure 4.  $I$  and  $Q$  Input Bandwidth ( $T_A$  = 25°C,  $F_{LO}$  = 800 MHz, LO Level = -2 dBm,  $I$  and  $Q$  Inputs Driven in Quadrature)

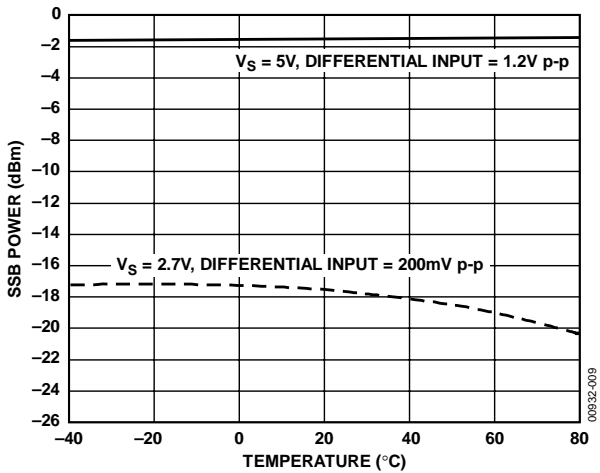

Figure 5. SSB  $P_{OUT}$  vs. Temperature ( $F_{LO}$  = 800 MHz, LO Level = -2 dBm,  $F_{BB}$  = 1 MHz,  $I$  and  $Q$  Inputs Driven in Quadrature)

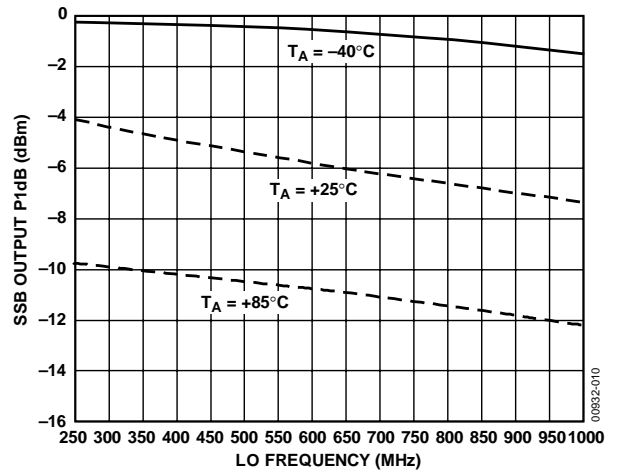

Figure 6. SSB Output 1 dB Compression Point ( $OP1dB$ ) vs.  $F_{LO}$  ( $V_S$  = 2.7 V, LO Level = -2 dBm,  $I$  and  $Q$  Inputs Driven in Quadrature,  $F_{BB}$  = 1 MHz)



Figure 7. SSB Output 1 dB Compression Point ( $OP1dB$ ) vs.  $F_{LO}$  ( $V_S$  = 5 V, LO Level = -2 dBm,  $I$  and  $Q$  Inputs Driven in Quadrature,  $F_{BB}$  = 1 MHz)



Figure 8. Carrier Feedthrough vs.  $F_{LO}$  (LO Level = -2 dBm,  $T_A$  = 25°C)



Figure 9. Carrier Feedthrough vs. Temperature  
( $F_{LO} = 800$  MHz, LO Level =  $-2$  dBm)

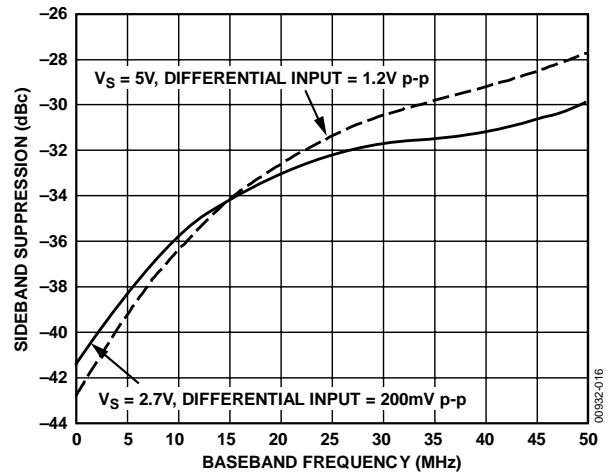

Figure 12. Sideband Suppression vs.  $F_{BB}$   
( $T_A = 25^\circ\text{C}$ ,  $F_{LO} = 800$  MHz, LO Level =  $-2$  dBm,  
I and Q Inputs Driven in Quadrature)

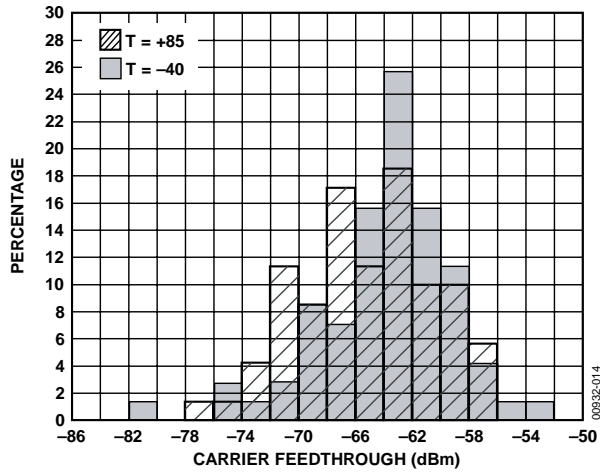

Figure 10. Carrier Feedthrough Distribution at Temperature Extremes After  
Feedthrough Nulled to  $< -65$  dBm at  $T_A = 25^\circ\text{C}$   
( $F_{LO} = 800$  MHz, LO Level =  $-2$  dBm)

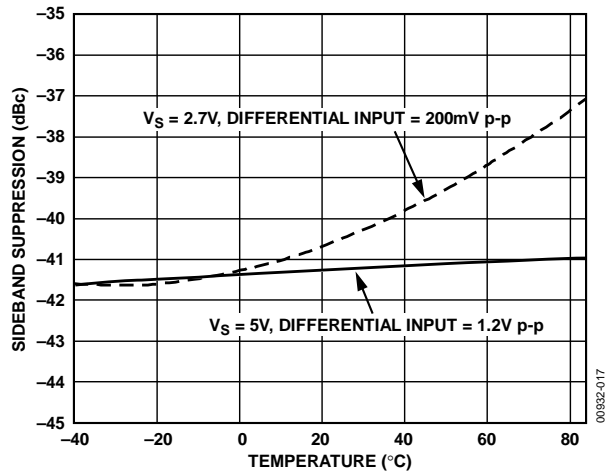

Figure 13. Sideband Suppression vs. Temperature  
( $F_{LO} = 800$  MHz, LO Level =  $-2$  dBm,  $F_{BB} = 1$  MHz,  
I and Q Inputs Driven in Quadrature)



Figure 11. Sideband Suppression vs.  $F_{LO}$   
( $T_A = 25^\circ\text{C}$ , LO Level =  $-2$  dBm,  $F_{BB} = 1$  MHz,  
I and Q Inputs Driven in Quadrature)

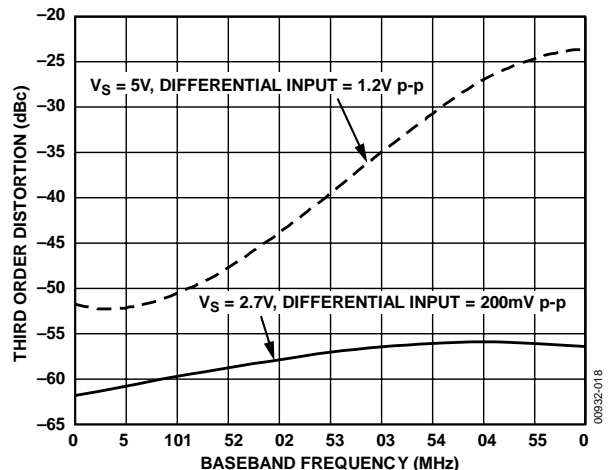

Figure 14. Third Order Distortion vs.  $F_{BB}$   
( $T_A = 25^\circ\text{C}$ ,  $F_{LO} = 800$  MHz, LO Level =  $-2$  dBm,  
I and Q Inputs Driven in Quadrature)



Figure 15. Third Order Distortion vs. Temperature ( $F_{LO} = 800$  MHz, LO Level = -2 dBm,  $F_{BB} = 1$  MHz, I and Q Inputs Driven in Quadrature)



Figure 18. Power Supply Current vs. Temperature

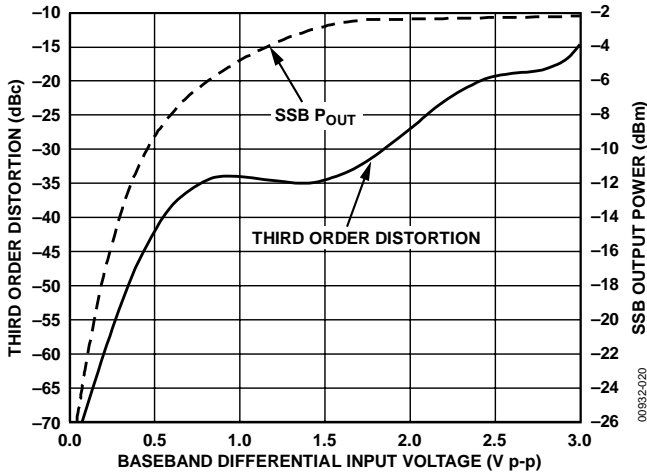

Figure 16. Third Order Distortion and SSB  $P_{OUT}$  vs. Baseband Differential Input Voltage ( $T_A = 25^\circ\text{C}$ ,  $F_{LO} = 800$  MHz, LO Level = -2 dBm,  $F_{BB} = 1$  MHz,  $V_S = 2.7$  V)



Figure 19. Smith Chart of LOIN Port S11 (LOIP Pin AC-Coupled to Ground); Curves with Balun and External Termination Resistors Also Shown ( $V_S = 5$  V,  $T_A = 25^\circ\text{C}$ )



Figure 17. Third Order Distortion and SSB  $P_{OUT}$  vs. Baseband Differential Input Voltage ( $T_A = 25^\circ\text{C}$ ,  $F_{LO} = 800$  MHz, LO Level = -2 dBm,  $F_{BB} = 1$  MHz,  $V_S = 5$  V)



Figure 20. Return Loss (S22) of VOUT Output ( $T_A = 25^\circ\text{C}$ )





Figure 21. Noise Floor vs. LO Input Power  
 ( $T_A = 25^\circ\text{C}$ ,  $F_{LO} = 800\text{ MHz}$ ,  $V_S = 5\text{ V}$ , All I and Q Inputs Are DC-Biased to 0.7 V)  
 Noise Measured at 20 MHz Offset from Carrier

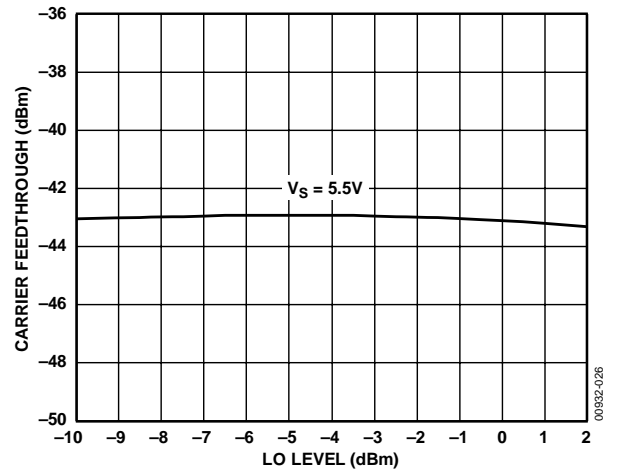

Figure 22. LO Feedthrough vs. LO Input Power  
 ( $T_A = 25^\circ\text{C}$ ,  $F_{LO} = 800\text{ MHz}$ ,  $V_S = 5.5\text{ V}$ )

EQUIVALENT CIRCUITS



Figure 23. Circuit A

00932-003

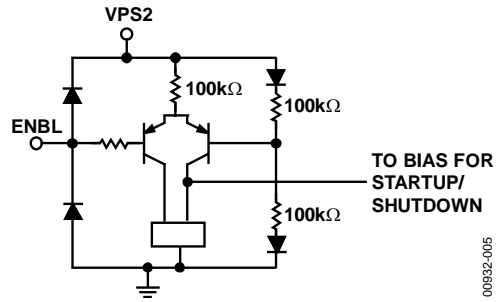

Figure 25. Circuit C

00932-005

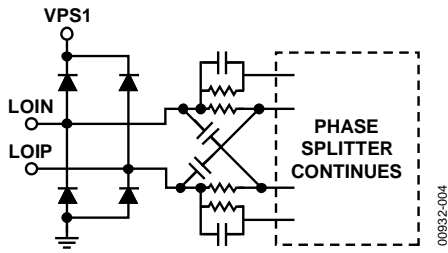

Figure 24. Circuit B

00932-004

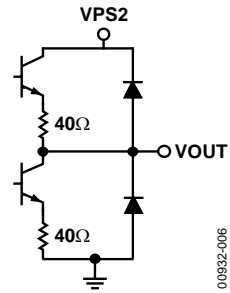

Figure 26. Circuit D

00932-006

## CIRCUIT DESCRIPTION

### OVERVIEW

The AD8345 can be divided into the following sections: local oscillator (LO) interface, mixer, differential voltage-to-current (V-to-I) converter, differential-to-single-ended (D-to-S) converter, and bias. A block diagram of the part is shown in Figure 27.



Figure 27. AD8345 Block Diagram

The LO interface generates two LO signals at  $90^\circ$  of phase difference with each other, to drive two mixers in quadrature. Baseband signals are converted into current form in the differential V-to-I converters, feeding into the two mixers. The outputs of the mixers are combined to feed the differential-to-single-ended converter, which provides a  $50\ \Omega$  output interface. Bias currents to each section are controlled by the enable (ENBL) signal. A detailed description of each section follows.

### LO INTERFACE

The LO interface consists of interleaved stages of polyphase phase splitters and buffer amplifiers. The polyphase phase splitter contains resistors and capacitors connected in a circular manner to split the LO signal into I and Q paths in precise quadrature with each other. The signal on each path goes through a buffer amplifier to make up for the loss and high frequency roll-off. The two signals then go through another polyphase network to enhance the quadrature accuracy. The broad operating frequency range (140 MHz to 1000 MHz) is achieved by staggering the RC time constants of each stage of the phase splitters. The outputs of the second phase splitter are fed into the driver amplifiers for the mixers' LO inputs.

### DIFFERENTIAL VOLTAGE-TO-CURRENT CONVERTER

In this circuit, each baseband input pin is connected to an op amp driving a transistor connected as an emitter follower. A resistor between the two emitters maintains a varying current proportional to the differential input voltage through the transistor. These currents are fed to the two mixers in differential form.

### MIXERS

There are two double-balanced mixers, one for the in-phase channel (I channel) and one for the quadrature channel (Q channel). Each mixer uses the Gilbert-cell design with four cross-connected transistors. The bases of the transistors are driven by the LO signal of the corresponding channel. The output currents from the two mixers are summed together in two load resistors. The signal developed across the load resistors is sent to the differential-to-single-ended converter.

### DIFFERENTIAL-TO-SINGLE-ENDED CONVERTER

The differential-to-single-ended converter consists of two emitter followers driving a totem-pole output stage whose output impedance is established by the emitter resistors in the output transistors. The output of this stage is connected to the output pin (VOUT).

### BIAS

A band gap reference circuit based on the  $\Delta$ -VBE principle generates the proportional-to-absolute temperature (PTAT) as well as temperature-stable currents used by the different sections as references. When the band gap reference is disabled by pulling down the voltage at the ENBL pin, all other sections are shut off accordingly.

## BASIC CONNECTIONS

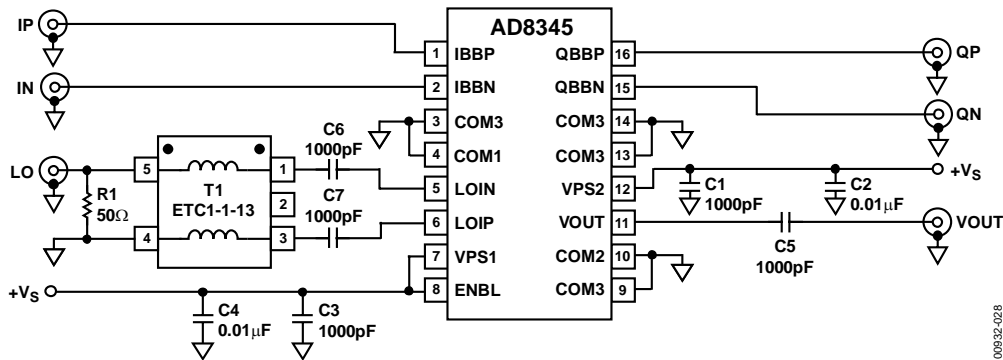

Figure 28. Basic Connections

The basic connections for operating the AD8345 are shown in Figure 28. A single power supply of between 2.7 V and 5.5 V is applied to the VPS1 pin and the VPS2 pin. A pair of ESD protection diodes is connected internally between the VPS1 pin and the VPS2 pin so these must be tied to the same potential. Both pins should be individually decoupled using 1000 pF and 0.01 μF capacitors, located as close as possible to the device. For normal operation, the enable pin (ENBL) must be pulled high. The turn-on threshold for ENBL is  $V_S/2$ . COM1 to COM3 should all be tied to the same low impedance ground plane.

### LO DRIVE

In Figure 28, a 50 Ω resistor to ground combines with the device's high input impedance to provide an overall input impedance of approximately 50 Ω (see Figure 19 for a plot of LO port input impedance). For maximum LO suppression at the output, a differential LO drive is recommended. In Figure 28, this is achieved using a balun (M/A-COM part number ETC1-1-13).

The outputs of the balun are ac-coupled to the LO inputs, which have a bias level of approximately 1.8 V dc. An LO drive level of -2 dBm is recommended for lowest output noise. Higher levels degrade linearity while lower levels tend to increase the noise floor slightly. For example, reducing the LO power from -2 dBm to -10 dBm increases the noise floor by approximately 0.3 dB (see Figure 21).

The LO input pins can be driven single-ended at the expense of slightly higher LO leakage. LOIN is ac-coupled to ground using a capacitor and LOIP is driven through a coupling capacitor from a (single-ended) 50 Ω source. (This scheme could also be reversed with the drive signal being applied to LOIN.)

### LO FREQUENCY RANGE

The frequency range on the LO input is limited by the internal quadrature phase splitter. The phase splitter generates drive signals for the internal mixers which are 90° out of phase relative to one another.

Outside of the specified LO frequency range of 140 MHz to 1 GHz, this quadrature accuracy degrades, resulting in decreased sideband suppression. See Figure 11 for a plot of sideband suppression vs. LO frequency from 250 MHz to 1 GHz. Figure 29 shows the sideband suppression of a typical device from 70 MHz to 300 MHz.

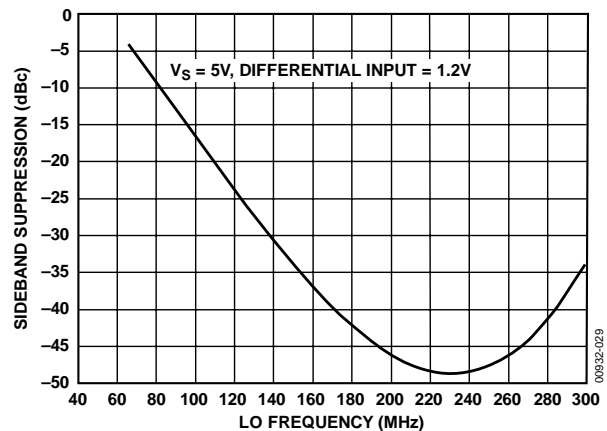

Figure 29. Typical Lower Frequency Sideband Suppression Performance

## BASEBAND I AND Q CHANNEL DRIVE

The I channel and Q channel baseband inputs should be driven differentially. This is convenient as most modern high-speed DACs have differential outputs. For optimal performance at  $V_S = 5\text{ V}$ , the drive signal should be a 1.2 V p-p differential signal with a bias level of 0.7 V; that is, each input should swing from 0.4 V to 1 V. If the AD8345 is being run on a lower supply voltage, then the peak-to-peak voltage on the I and Q channel inputs must be reduced to avoid input clipping. For example, at a supply voltage of 2.7 V, a 200 mV p-p differential drive is recommended. This results in a corresponding reduction in output power (see Figure 3). The I and Q inputs have a large input bandwidth of approximately 80 MHz. At lower baseband input levels, the input bandwidth increases (see Figure 4).

If the baseband signal has a high peak-to-average ratio (such as CDMA or WCDMA), then the rms signal strength must be backed off from this peak level in order to prevent clipping of the signal peaks.

Clipping of signal peaks tends to increase signal leakage into adjacent channels. Backing off the I and Q signal strength, in the manner recommended, reduces the output power by a corresponding amount. This also applies to multicarrier applications where the per-carrier output power is lower by 3 dB for each doubling of the number of output carriers.

The I and Q inputs have high input impedances because they connect directly to the bases of PNP transistors. If a dc-coupled filter is being used between a DAC and the modulator inputs, then the filter must be terminated with the appropriate resistance. If the filter is differential, then the termination resistor should be connected across the I and Q differential inputs.

## REDUCTION OF LO LEAKAGE

Because the I and Q signals are being effectively multiplied with the LO, any internal offset voltages on these inputs result in leakage of the LO. The nominal LO leakage of  $-42\text{ dBm}$ , which results from these internal offset voltages, can be reduced further by applying offset compensation voltages on the I and Q inputs. (Note that LO feedthrough is reduced by varying the differential offset voltages on the I and Q inputs, not by varying the nominal bias level of 0.7 V.) The reduction is easily accomplished by programming (and then storing) the appropriate DAC offset code. This does, however, require dc coupling the path from the DAC to the I and Q inputs. (DC coupling is also advantageous from the perspective of I and Q input biasing if the DAC is capable of delivering a bias level of 0.7 V.)

The procedure for reducing the LO feedthrough is simple. In order to isolate the LO in the output spectrum, a single sideband configuration is recommended (set I and Q signals to sine and cosine waves at, for example, 100 kHz; set LO to  $F_{RF} - 100\text{ kHz}$ ). An offset voltage is applied from the I DAC until the LO leakage reaches a trough. With this offset level held, an offset voltage is applied to the Q DAC until a (lower) trough is reached.

LO leakage compensation holds up well over temperature. Figure 10 shows the effect of temperature on LO leakage after compensation at ambient.

Compensated LO leakage degrades somewhat as the frequency is moved away from the frequency at which the compensation was performed. This is due to the effects of LO to RF output leakage, which is not a result of offsets on the I and Q inputs.

## SINGLE-ENDED I AND Q DRIVE

Where only single-ended I and Q signals are available, a differential amplifier such as the AD8132 or AD8138 can be used to generate the required differential drive signal for the AD8345.

Although most DACs have differential outputs, using a single-ended, low-pass filter between the dual DAC and the I and Q inputs can be more desirable from the perspective of component count and cost. As a result, the output signal from the filter must be converted back to differential mode and possibly be rebiased to 0.7 V common mode.

Figure 30 shows a circuit that converts a ground-referenced, single-ended signal to a differential signal and adds the required 0.7 V bias voltage. Two AD8132 differential op amps configured for unity gain are used. With a  $50\ \Omega$  input impedance, this circuit is configured to accept a signal from a  $50\ \Omega$  source (for example, a low-pass filter). The input impedance can be easily changed by replacing the  $49.9\ \Omega$  shunt resistor (and the corresponding  $24.9\ \Omega$  resistor on the inverting input) with the appropriate value. The required dc-bias level is conveniently added to the signal by applying 0.7 V to the  $V_{OCM}$  pins of the differential amplifiers.

Differential amplifiers, such as the AD8132 and AD8138, can also be used to implement active filters. For more information on this topic, refer to the data sheets of these devices.



Figure 30. Single-Ended IQ Drive Circuit

Note that this circuit assumes that the single-ended I and Q signals are ground-referenced. Any differential dc-offsets result in increased LO leakage at the output of the AD8345.

It is possible to drive the baseband inputs with a single-ended signal biased to 0.7 V, with the unused inputs being biased to a dc level of 0.7 V. However, this mode of operation is not recommended because any dc level difference between the bias level of the drive signal and the dc level on the unused input (including the effect of temperature drift) results in increased LO leakage. In addition, the maximum output power is reduced by 6 dB.

## RF OUTPUT

The RF output is designed to drive a 50 Ω load but should be ac coupled as shown in Figure 28. If the I and Q inputs are driven in quadrature by 1.2 V p-p signals, then the resulting output power is approximately -1 dBm (see Figure 3). The RF output impedance is very close to 50 Ω. As a result, no additional matching circuitry is required if the output is driving a 50 Ω load.

## APPLICATION WITH TxDAC®

Figure 31 shows the AD8345 driven by the AD9761 TxDAC. (Any of the devices in the Analog Devices' TxDAC family can also be used in this application.)

The I and Q DACs generate differential output currents of 0 mA to 10 mA and 10 mA to 0 mA, respectively. The combination of 140 Ω resistors shunted to ground off each DAC output, along with 210 Ω resistors shunted between each differential DAC pair, produces a baseband signal into the AD8345 I and Q inputs that has a differential peak-to-peak swing of 1.2 V with a dc common-mode bias of 700 mV.

00682-030



Figure 31. AD8345/TxDAC Interface

## SOLDERING INFORMATION

The AD8345 is packaged in a 16-lead TSSOP\_EP package. For optimum thermal conductivity, the exposed pad can be soldered to the exposed metal of a ground plane. This results in a junction-to-air thermal impedance ( $\theta_{JA}$ ) of 30°C/W. However, soldering is not necessary for safe operation. If the exposed pad is not soldered down, then the  $\theta_{JA}$  is equal to 95°C/W.

## EVALUATION BOARD

Figure 32 shows the schematic of the AD8345 evaluation board. Note that uninstalled components are marked as open. This is a 4-layer board, with the two center layers used as ground plane, and top and bottom layers used as signal and power planes.

The board is powered by a single supply ( $V_S$ ) in the range 2.7 V to 5.5 V. The power supply is decoupled by 0.01  $\mu$ F and 1000 pF capacitors. The circuit closely follows the basic connection schematic with SW1 in Position B. If SW1 is in Position A, the enable pin (ENBL) is pulled to ground by a 10 k $\Omega$  resistor, and the device is in its power-down mode.

All connectors are SMA-type. The I and Q inputs are dc-coupled to allow a direct connection to a dual DAC with differential outputs. Resistor pads are provided in case termination at the I and Q inputs is required. The local oscillator input (LO) is terminated to approximately 50  $\Omega$  with an external 50  $\Omega$  resistor to ground. A 1:1 wide-band transformer (ETC1-1-13) provides a differential drive to the AD8345's differential LO input.

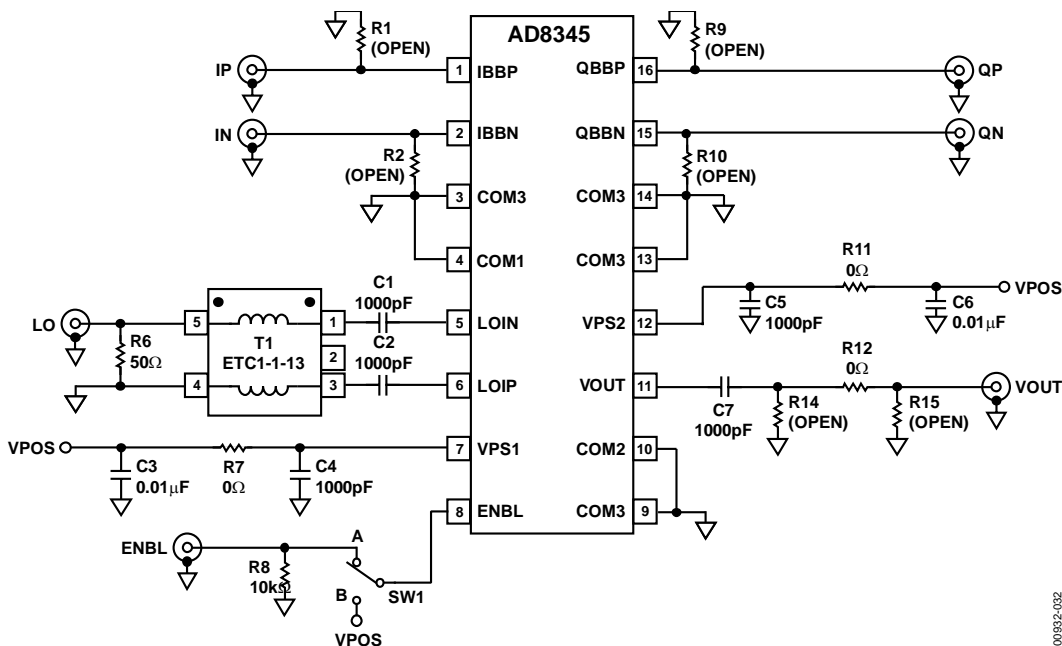

Figure 32. Evaluation Board Schematic

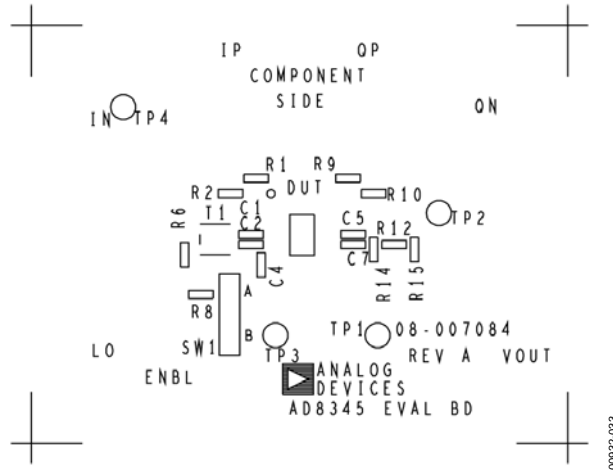

Figure 33. Evaluation Board Silkscreen

00932-033



Figure 34. Layout of Evaluation Board, Top Layer

00932-034



Figure 35. Layout of Evaluation Board, Bottom Layer

00932-035



# CHARACTERIZATION SETUPS

## SSB SETUP

Essentially, two primary setups are used to characterize the AD8345. These setups are shown in Figure 37 and Figure 38. Figure 37 shows the setup used to evaluate the product as a single sideband modulator. The interface board converts the single-ended I and Q inputs from the arbitrary function generator to differential inputs with a dc bias of approximately 0.7 V. The interface board also provides connections for power supply routing. The HP34970A and its associated plug-in 34901 are used to monitor power supply currents and voltages being supplied to the AD8345 characterization board. Two HP34907 plug-ins are used to provide additional miscellaneous dc and control signals to the interface board. The LO inputs are driven directly by an RF signal generator, and the output is measured directly with a spectrum analyzer. With the I channel driven with a sine wave and the Q channel driven with a cosine wave, the lower sideband is the single sideband output. The typical SSB output spectrum is shown in Figure 36.

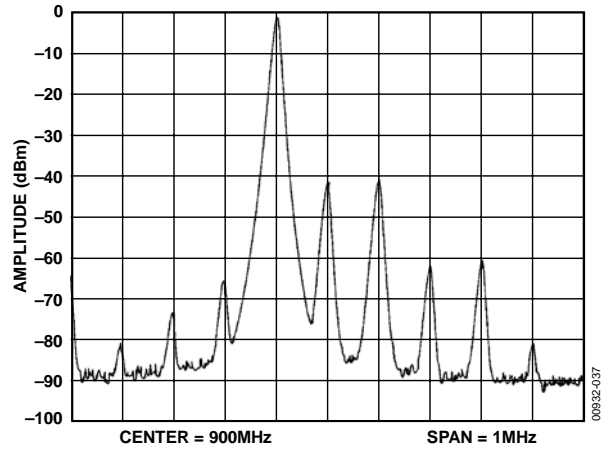

Figure 36. Typical SSB Output Spectrum



Figure 37. Characterization Board SSB Test Setup

## MODULATED WAVEFORM SETUP

To evaluate the AD8345 with modulated waveforms, the setup shown in Figure 38 is used. A Rohde & Schwarz AMIQ signal generator with differential outputs is used to generate the baseband signals. For all measurements, the input level on each baseband input pin is  $0.7\text{ V} \pm 0.3\text{ V}$  peak. The output is measured with a Rohde & Schwarz FSIQ spectrum/vector analyzer.

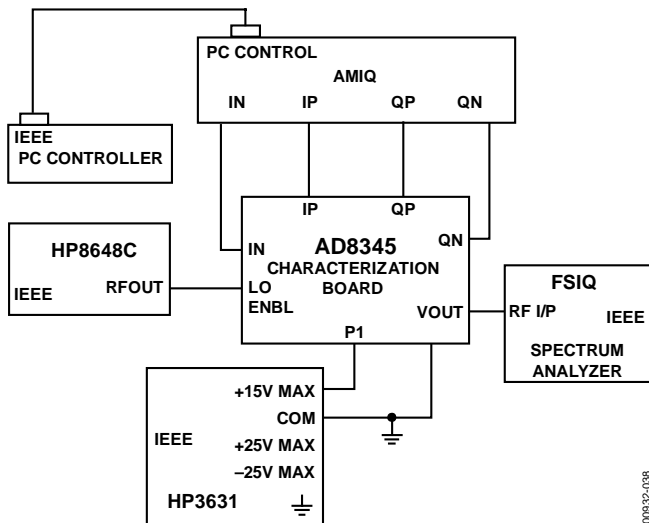

Figure 38. Test Setup for Evaluating AD8345 with Modulated Waveforms

## CDMA IS95

To measure ACPR, the I and Q input signals used are generated with Pilot channel (Walsh Code 00), Sync channel (WC 32), Paging channel (WC 01), and six Traffic (WC 08, 09, 10, 11, 12, 13) channels active. Figure 39 shows the typical output spectrum for this configuration.

To perform EVM, Rho, phase, and amplitude balance measurements, the I and Q input signals used are generated with only the Pilot channel (Walsh Code 00) active.



Figure 39. Typical IS95 Output Spectrum

## WCDMA 3GPP

To evaluate the AD8345 for WCDMA, the 3GPP standard is used with a chip rate of 3.84 MHz. The plot in Figure 40 is an ACPR plot of the AD8345 using Test Model 1 from the 3GPP specification with 64 channels active.

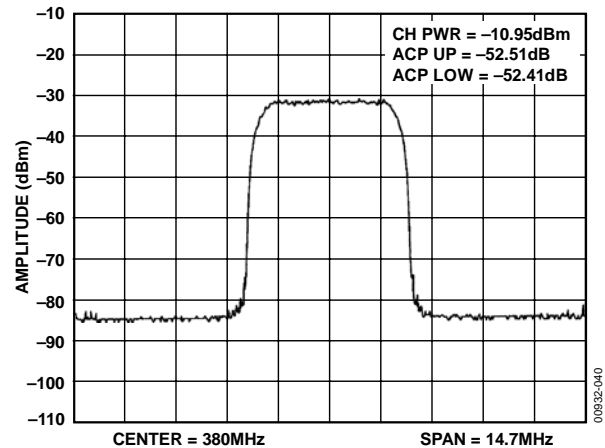

Figure 40. Typical AD8345 WCDMA 3GPP Output Spectrum

## GSM

To compare the AD8345 output to the GSM transmit mask, I and Q signals are generated using MSK modulation, GSM differential coding, a Gaussian filter, and a symbol rate of 270.833 kHz. The transmit mask is manually generated on the FSIQ using the GSM BTS specification for reference. The plot in Figure 41 shows that the AD8345 meets the GSM transmit mask requirements.



Figure 41. Typical AD8345 GSM Output Spectrum

## OUTLINE DIMENSIONS

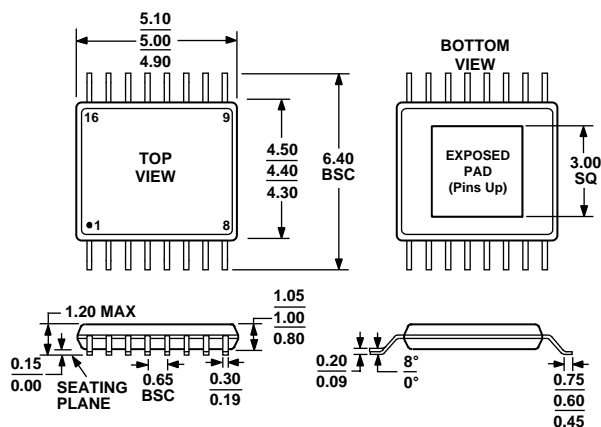

Figure 42. 16-Lead Thin Shrink Small Outline with Exposed Pad (TSSOP\_EP)  
(RE-16-2)  
Dimensions shown in millimeters

## ORDERING GUIDE

Model	Temperature Range	Package Description	Package Option
AD8345ARE	-40°C to +85°C	16-Lead TSSOP with Exposed Pad, Tube	RE-16-2
AD8345ARE-REEL7	-40°C to +85°C	16-Lead TSSOP with Exposed Pad, 7" Tape and Reel	RE-16-2
AD8345AREZ <sup>1</sup>	-40°C to +85°C	16-Lead TSSOP with Exposed Pad, Tube	RE-16-2
AD8345AREZ-RL7 <sup>1</sup>	-40°C to +85°C	16-Lead TSSOP with Exposed Pad, 7" Tape and Reel	RE-16-2
AD8345-EVAL		Evaluation Board	

<sup>1</sup> Z = Pb-free part.

**AD8345**

**NOTES**