

## L9310 Line Interface and Line Access Circuit Full-Feature SLIC, Ringing Relay, and Test Access Device

---

### Introduction

The Agere Systems Inc. L9310 is a combination full-feature, ultralow-power SLIC, solid-state ringing access relay, and line test matrix. It is part of a pin-for-pin compatible family of devices designed to serve a wide variety of applications. The L9310 is optimized for European Access applications and North American access where per-line testing and GR-909 longitudinal balance are required.

### Features

#### SLIC

- 5 V and battery operation
- Optional automatic battery switch
- 15 operational and test modes
- Appropriate for 46 dB longitudinal balance applications
- Minimal external components required at all interfaces
- Ultralow power dissipation
- Software/hardware adjustable dc parameters and supervision thresholds
- Meter pulse compatible
- Ground start/ground key compatible

#### Solid-State Ring Relay

- Low impulse noise
- Current-limited switches/thermal protection

#### Line Test Matrix

- Single-ended or differential measurements
- Current or voltage sense
- ac or dc measurements
- Dedicated analog input and output

### Applications

- Pair Gain
- Digital Loop Carrier (DLC)
- Central Office (CO)
- Fiber-in-the-Loop (FITL)

### Description

The L9310 electronic line interface and line access circuit (LILAC) provides all the functions that are necessary to interface a codec to the tip and ring of a subscriber loop, integrating the battery feed and ringing access relay and line test access in one low-power, low-cost package.

The L9310 requires a 5 V and battery supply to operate. Included is an automatic battery switch. The battery feed offers forward and reverse battery, on-hook transmission, ground start, ground key, and meter pulse operational modes. It also has a low-power scan and a disconnect mode.

In all operating states, this IC is designed for minimal power dissipation. This device is designed to minimize the number of external components required at all interfaces.

The dc template, current limit, and overhead voltage and loop supervision threshold are programmable via an applied voltage source. The voltage source may be an external programmable voltage source or derived from the V<sub>REF</sub> SLIC output.

The integrated solid-state switch offers power ringing access. Impulse noise is minimized, thus eliminating the need for external zero-cross switching circuitry.

The L9310 provides line test capability. The differential or single-ended ac and dc line voltage or current may be measured by the L9310.

**Table of Contents**

<b>Contents</b>	<b>Page</b>	<b>Contents</b>	<b>Page</b>
Introduction.....	1	Power Control Resistor .....	34
Features .....	1	dc Loop Current Limit .....	34
SLIC .....	1	Overhead Voltage .....	35
Solid-State Ring Relay .....	1	Loop Range .....	36
Line Test Marix.....	1	Battery Feed.....	36
Applications.....	1	Battery Reversal Rate .....	37
Description .....	1	Longitudinal to Metallic Balance.....	37
Features .....	4	Supervision.....	37
Description.....	4	Loop Closure.....	37
Architecture .....	9	Ring Trip .....	38
Pin Information .....	10	Tip or Ring Ground Detector .....	38
Operating States.....	14	Switching Behavior.....	38
Input State Coding .....	14	Make-Before-Break Operation .....	38
State Definitions .....	16	Break-Before-Make Operation .....	39
Primary Control Modes .....	16	Protection .....	39
Powerup, Forward Battery.....	16	External Protection.....	39
Powerup, Reverse Battery .....	16	Active Mode Response at PT/PR.....	40
Scan .....	16	Ring Mode Response at PT/PR.....	41
Ground Start.....	16	Internal Tertiary Protection.....	41
Ringing .....	17	Diode Bridge.....	41
Disconnect—Break Before Make .....	17	Battery Out of Range Detector: High (Magnitude) .....	41
Tip Amp .....	17	Battery Out of Range Detector: Low (Magnitude) .....	41
Ring Amp .....	17	Special Functions .....	42
Tip and Ring Amp.....	17	Periodic Pulse Metering (PPM).....	42
Reset.....	17	Line Test .....	42
Secondary Control Mode States .....	17	ac Applications .....	44
Voltage: Tip to Ground .....	17	ac Parameters.....	44
Voltage: Ring to Ground.....	17	Codec Types.....	44
Voltage: Tip to Ring .....	17	ac Interface Network .....	44
Current: Tip to Ring—VTX .....	18	Design Tools .....	45
Current: Tip to Ring—VITR .....	18	First-Generation Codec ac Interface Network.....	45
Reference Voltage .....	18	First-Generation Codec ac Interface Network: Resistive Termination.....	46
PPM On.....	18	Example 1, Real Termination .....	47
PPM Off/TEST Off.....	18	Hybrid Balance.....	47
Special States .....	18	First-Generation Codec ac Interface Network: Complex Termination .....	50
Thermal Shutdown .....	18	Complex Termination Impedance Design .....	50
Battery Out of Range .....	19	ac Interface Using First-Generation Codec .....	50
Absolute Maximum Ratings .....	19	Set Z <sub>TG</sub> —Gain Shaping .....	50
Electrical Characteristics .....	20	Transmit Gain.....	51
Ring Trip Detector .....	21	Receive Gain.....	52
PPM .....	21	Hybrid Balance .....	52
Test .....	22	Blocking Capacitors.....	53
SLIC Two-Wire Port .....	23	Basic Loop Start Application Using T7504 Type Codec .....	54
Analog Pin Characteristics .....	25	Third-Generation Codec ac Interface Network: Complex Termination .....	57
ac Feed Characteristics .....	26	Outline Diagram.....	59
Logic Inputs and Outputs, V <sub>DD</sub> = 5.0 V .....	27	44-Pin PLCC .....	59
Timing Requirements .....	27	Ordering Information.....	60
Switch Characteristics.....	28		
On-State Switch I-V Characteristics.....	29		
Test Configurations .....	30		
Applications .....	32		
dc Characteristics .....	32		
Power Control.....	32		
Power Derating.....	32		
Automatic Battery Switch .....	33		

Table of Contents (continued)

Figures	Page	Tables	Page
Figure 1. Architecture Diagram.....	9	Table 1. Pin Descriptions .....	11
Figure 2. Test Diagram.....	10	Table 2. Primary Control States .....	15
Figure 3. 44-Pin PLCC .....	10	Table 3. Secondary Control States .....	15
Figure 4. Timing Requirements .....	27	Table 4. Supervision Coding.....	15
Figure 5. On-State I-V Characteristic .....	29	Table 5. Device Operating Conditions and Powering .....	20
Figure 6. Basic Test Circuit .....	30	Table 6. Ring Trip Detector .....	21
Figure 7. Metallic PSRR .....	31	Table 7. PPM .....	21
Figure 8. Longitudinal PSRR .....	31	Table 8. ac Test Source .....	22
Figure 9. Longitudinal Balance .....	31	Table 9. Test Sense .....	22
Figure 10. Longitudinal Impedance .....	31	Table 10. SLIC Two-Wire Port .....	23
Figure 11. ac Gains .....	31	Table 11. Analog Pin Characteristics .....	25
Figure 12. L9310 Loop/Battery Current (with Battery Switch) vs. Loop Resistance .....	33	Table 12. ac Feed Characteristics .....	26
Figure 13. Tip/Ring Voltage .....	36	Table 13. Logic Inputs and Outputs .....	27
Figure 14. L9310 Loop Current vs. Loop Voltage.....	37	Table 14. Timing Requirements .....	27
Figure 15. ac Equivalent Circuit.....	46	Table 15. Break Switches (SW1, 2) .....	28
Figure 16. Agere T7504 First-Generation Codec Resistive Termination, Nonmeter Pulse Application, Single Battery Operation.....	48	Table 16. Ring Return Switch (SW3) .....	28
Figure 17. Interface Circuit Using First-Generation Codec (Blocking Capacitors Not Shown) .....	51	Table 17. Ringing Access Switch (SW4) .....	29
Figure 18. ac Interface Using First-Generation Codec (Including Blocking Capacitors) for Complex Termination Impedance .....	53	Table 18. Typical Active Mode On- to Off-Hook Tip/Ring Current-Limit Transient Response .....	35
Figure 19. Basic Loop Start Application Using T7504 Type Codec .....	54	Table 19. FB1/FB2 Values vs. Typical Ramp Time .....	37
Figure 20. L9310 for Agere T8536 Third-Generation Codec Meter Pulse Application, Dual Battery Operation, ac and dc Parameters, Fully Programmable .....	57	Table 20. Break-Before-Make Logic Control Sequence Device Switching.....	39
		Table 21. TESTLEV Output Options.....	43
		Table 22. L9310 Parts List for Agere T7504 First-Generation Codec Resistive Termina- tion, Nonmeter Pulse Application, Single Battery Operation .....	49
		Table 23. L9310 Parts List for Agere T7504 First-Generation Codec Complex Termina- tion, Meter Pulse Application, Dual Battery Operation .....	55
		Table 24. L9310 Parts List for Agere T8536 Third-Generation Codec Meter Pulse Applica- tion, Dual Battery Operation, ac and dc Pa- rameters, Fully Programmable.....	58

## Features

- SLIC, solid-state ring relay, and line test access, integrated into a single package
- 5 V and battery operation
- User-defined power control options:
  - Automatic battery switch
  - Power control resistor
  - Package thermal capabilities
- Minimal external components required
- Operating states:
  - Forward active
  - Reverse active (controlled rate of reversal)
  - Scan
  - Ground start (tip open)
  - All-off or disconnect
  - Ring
  - Periodic pulse metering (PPM) active modes
  - Line test modes (dc/ac line voltage/current)
- Ultralow power:
  - Scan, 15 mW
  - Active states, on-hook, 75 mW
  - Ring mode, on-hook, 90 mW
  - Disconnect, 10 mW
- Adjustable overhead voltage:
  - Default overhead adequate for 3.14 dB into 900  $\Omega$  overload
  - Controlled rate of overhead adjustment
- Latched parallel input data interface with reset
- Interrupt (unlatched) based loop status monitor
- Adjustable current limiter:
  - 10 mA to 70 mA programming range
- Adjustable loop closure detector with hysteresis:
  - 4 mA detect, 2.5 mA no detect minimum, upper limit of 15 mA detect
  - Hysteresis, typical 20% of programmed on-hook to off-hook threshold
- Ring trip detector:
  - Single-pole filtering
- Thermal shutdown protection with hysteresis
- Line break switch will foldover into a low-current state under high-voltage fault conditions
- Battery out-of-range monitor circuit:
  - All-off upon loss of battery (low battery condition)
  - All-off upon high battery (fault condition)
- Longitudinal balance:
  - ETSI/ITU-T, GR-909 balance
- Ground start:
  - Tip open state
  - Ring ground detector
- Ground key:
  - Tip/ring ground detector
- Meter pulse compatible:
  - Dedicated meter pulse signal input
  - On-hook transmission of PPM (up to 5 Vrms)
  - Provides convenient access for hybrid filtering of meter pulse
- Line test:
  - Line test modes (ac or dc):
    1. Voltage tip to ground
    2. Voltage ring to ground
    3. Voltage tip to ring
    4. Current tip to ring
    5. Current tip to ground
    6. Current ring to ground
  - Inject test tones through codec interface or dedicated input pin
  - Analog output at dedicated output pin
- RFI/EMC-EN 300 386-2 V1.1.3 (1997-12)
- Integrated 2 Form C ring relay:
  - Low impulse noise
  - Current-limited switches
  - Break-before-make and make-before-break switching
- Meets ITU-T K20, ITU-T K21, and *Telcordia*\* GR1089 requirements with external protection device
- 44-pin, surface-mount plastic package (PLCC)

## Description

The L9310 electronic line interface and line access circuit (LILAC) provides all the functions that are necessary to interface a codec to the tip and ring of a subscriber loop, integrating the battery feed and ringing access relay in one low-power, low-cost package. The physical construction of the device is two chips. The first chip is manufactured in Agere 90 V complementary bipolar integrated circuit (CBIC-S) technology. This chip contains the SLIC functionality:

- ac transmission path
- dc feedback and functions
- Active dc current limit
- Active mode loop supervision
- Thermal shutdown

\* *Telcordia* is a trademark of Bell Communications Research, Inc.

## Description (continued)

The second chip is manufactured in Agere dielectrically isolated 320 V bipolar CMOS diffused metal oxide semiconductor (BCDMOS III) technology. This chip contains the following:

- Ring access relay
- Scan clamp circuitry
- Logic control
- Ring trip
- Test
- PPM
- Thermal shutdown
- Battery monitor circuit

The LILAC family requires a +5 V and battery supply to operate. No -5 V supply is required. A battery switch is included that automatically, based on subscriber loop length, will apply either the primary higher-voltage battery or an optional lower-voltage auxiliary battery. Use of this feature will minimize off-hook power dissipation.

The switch point is a function of the user-programmed dc current limit and the magnitude of the auxiliary battery. Switching from the high-voltage to low-voltage battery is quiet, without interruption of the dc loop current, thus preventing any impulse noise generation at the switch point. Design equations for the switch point and a graph showing loop/battery current versus loop resistance are given in the dc Characteristics section of this data sheet.

If the user does not want to provide an auxiliary battery, the design of the L9310 battery switch allows use of a power control resistor at the auxiliary battery input. This scheme will not reduce short-loop, off-hook power dissipation, but it will control power dissipation on the SLIC by sharing power among the SLIC, power resistor, and dc loop. However, in most cases, without the auxiliary battery, the power dissipation capabilities of the 44-pin PLCC package are adequate so that the power control resistor will not be needed. Design equations for power control options are given in the dc Characteristics section of this data sheet.

The L9310 has two active transmission ready states, forward active and reverse active. Both on-hook and off-hook transmission are provided during the forward and reverse battery modes. Battery reversal is quiet, without breaking the ac path. Rate of battery reversal may be ramped to control switching time via optional external capacitors. Equations relating rate of battery reversal to these optional external capacitors are given in the dc Characteristics, Power Control section of this data sheet.

A low-power scan mode is available to reduce idle mode on-hook power. This mode is realized by using a scan clamp circuit. In low-power scan mode:

- The scan clamp circuitry is active.
- Loop closure is active.
- All ac transmission, dc feed, and other supervision circuits, including ring trip, are shut down.
- PPM and test are powered down.
- Thermal shutdown is active.
- Low battery sense shutdown is on.
- On-hook transmission is disabled.

When the scan clamp circuitry is on, overhead voltage is fixed and not controlled by OVH. When the scan clamp is on, current limit is not controlled by  $V_{PROG}$ ; rather, it is set by the internal capabilities of the scan clamp circuit. See the dc Loop Current Limit and Overhead Voltage sections of this data sheet for more details.

A forward disconnect mode, where all circuits are turned off and power is denied to the loop, is also provided. During this mode, the NSTAT supervision output will read on hook.

In the ring mode, the line break switches are opened and the power ring access switches are closed. In this mode, the ring trip detector in the SLIC is active and all other detectors and the tip/ring drive amplifiers are turned off to conserve power.

Make-before-break or break-before-make switching is achievable during ring cadence or ring trip. Toggling directly into or directly out of the ring mode table will give make-before-break switching. To achieve break-before-make switching, go to an intermediate all-off state (use forward disconnect state), before entering the ring mode or before leaving the ring mode. See the Switching Behavior section of this data sheet for more details on switching behavior.

Voltage transients or impulse noise associated with ring cadence or ring trip are minimized or eliminated with the L9310, thus possibly eliminating the need for external zero-cross switching circuitry.

A tip open switch configuration is also available for ground start applications. A common-mode current detector is included for ground start and ground key applications.

## **Description** (continued)

Both the ring trip and loop closure supervision functions are included. Loop closure threshold is set by applying a voltage source to the LCTH input. The voltage source may be an external voltage source or derived from the SLIC  $V_{REF}$  output. A programmable external voltage source may be used to provide software control of the loop closure threshold. Design equations for the loop closure threshold are given in the Supervision section of this data sheet. Hysteresis is included.

The ring trip detector requires only a single-pole filter at the input. This will minimize the required number of external components. To help minimize device power dissipation, the ring trip detector is active only during the power ring mode.

Ring trip and loop supervision status outputs appear in a common output pin, NSTAT. NSTAT is an unlatched supervision output; thus, an interrupt-based control scheme may be used.

The dc current limit is set in the active modes via an applied voltage source. The voltage source may be an external voltage source. The voltage may be derived via a resistor divider network from the  $V_{REF}$  SLIC output. A programmable external voltage source may be used to provide software control of the loop closure threshold. Design equations for this feature are given in the dc Characteristics section of this data sheet.

Programming range is 10 mA to 70 mA, with a maximum 2.5 Vrms meter pulse at tip and ring. Programming range is 10 mA to 45 mA, with a maximum 5 Vrms meter pulse at tip and ring.

Overhead is programmable in the active modes via an applied voltage source. The voltage source may be an external voltage source or derived via a resistor divider network from the  $V_{REF}$  SLIC output.

A programmable external voltage source may be used to provide software control of the overhead voltage. A potential application of this feature is to increase overhead during meter pulse injection and reduce overhead during periods of nonmeter pulse injection. The rate of

change of the overhead voltage may be controlled by use of a single external capacitor at the  $CF_1$  node. If the rate of change is uncontrolled, there may be audible noise associated with this transition. Design equations for this feature are given in the dc Characteristics section of this data sheet.

If the overhead is not programmed via a resistor, the device develops a default overhead adequate for a 3.14 dBm overload into 900  $\Omega$ . For the default overhead, OVH is connected to ground.

Overhead is not changed when the PPM input is turned on. Sufficient overhead to pass meter pulse signals must be set at OVH input.

The L9310 provides line test capability. In the test mode, a voltage proportional to the ac or dc tip to ground, ring to ground, tip to ring voltage or current may be presented at the SLIC TESTLEV output.

An ac test tone may also be applied to a test input, TESTSIG, or through the codec RCVN/RCVP interface. TESTSIG input is active upon entering a test state and remains active after leaving the test mode. By varying the frequency of the applied test tone, parameters such as line capacitance may be measured.

TESTSIG should be externally connected to the device's  $V_{REF}$  if it is not used during a test condition. This may be done by a high-impedance pull-up resistor. Additionally, TESTSIG should be ac coupled to the test signal generator.

Test level outputs at TESTLEV are referenced to the internally generated reference voltage  $V_{REF}$ . This reference voltage may also be output at TESTLEV so the users can compensate test results at TESTLEV for the internal reference.

Note that during nontest modes, TESTLEV is high impedance to conserve power. Input TESTSIG is turned off during any nontest mode and during the  $V_{REF}$  test mode.

## Description (continued)

The various test modes are achieved through a series of integrated analog switches that can reconfigure the SLIC to provide normal SLIC operation or the appropriate test function. Details are given in the Special Functions, Line Test section of this data sheet.

Test modes are achieved through the device state table. When entering a test mode, the state of the SLIC is unchanged; thus, testing can be done with the SLIC in forward and reverse battery active modes. Additionally, via the line break switches associated with the ring relay, use of a tip open or ring open state is used to make single-ended voltage and current measurements.

Data control is via a parallel latched data control scheme. Data latches are edge-level sensitive. Data is latched in when the LATCH control input goes low. While LATCH is low, the user cannot change the data control inputs. The data control inputs may only be changed when LATCH is high.

Incorporation of data latches allows for data control information and loop supervision information to be passed to and from the SLIC via data buses rather than on a per-line basis, thus minimizing routing complexity and board routing area.

A device RESET pin is included. When this pin is low, the logic inputs are overridden and the device will be reset into SLIC forward disconnect state and the switch into the all-off state. NSTAT is forced to the on-hook condition when RESET is low.

The overall device protection is achieved through a combination of an external secondary protector, along with an integrated thermal shutdown feature, a battery voltage window comparator, the break switch foldback characteristic, and the dc/dynamic current-limit response of the break and tip return switches.

For protection against long duration fault conditions, such as power cross and tip/ring shorts, a thermal shutdown mechanism is integrated into the device. Upon reaching the thermal shutdown temperature, the device will enter an all-off mode. Upon cooling, the device will re-enter the state it was in prior to thermal shutdown. Hysteresis is built in to prevent oscillation. During this mode, the NSTAT supervision output overrides the actual loop status and forces an off-hook.

The line break switches and tip return switch are current-limited switches. The current-limit mechanism limits current through the switch to the specified dc current limit under low frequency or dc faults (power cross and/or tip/ring to ground short) and limits the current to

the specified dynamic current-limit response under transient faults, such as lightning.

A foldover characteristic is incorporated into the line break switches within their I-V curve. Under voltage conditions higher than the normal operating range, such as may be seen under an extreme lightning or power cross fault condition, the line break switch will foldover into a low-current state. This feature allows for more relaxed specifications on the ring side protector, thus allowing for higher-voltage ringing signals. (Tip side protector is limited by the requirements on the tip return switch.) This feature is part of the overall device protection scheme.

This device uses a window comparator to force an all-off condition if the battery drops below, or rises above, a specified threshold.

Upon loss of  $V_{BAT1}$ , the L9310 will automatically enter an all-off mode. The device will enter this mode if the magnitude of the battery drops below a nominal 15 V and will remain in this mode until the magnitude of the battery rises above a typical 20 V. During this mode, the NSTAT supervision output will override the actual hook status and force an off-hook or logic low.

When the device is in the scan mode, because of the design of the scan clamp circuit, common-mode current can be forced into or out of the battery supply. Because of this, and depending upon power supply design, the magnitude of the battery may rise above the maximum operating condition during extended longitudinal currents or during a power cross fault condition. To prevent excess current from being forced into or out of the battery, if the magnitude of the battery rises typically above 75 V to 80 V, the device will enter an all-off state. The device will remain in the all-off state until the magnitude of the battery drops into the normal operating range. During this mode, the NSTAT supervision output will override the actual hook status and force an off-hook or logic low.

See the Protection section of this data sheet for more details on device protection. Please contact your Agere Account Representative for a recommended secondary protection device.

Longitudinal balance is consistent with European ETSI and North American GR-909 requirements.

## **Description** (continued)

The L9310 will support the PPM application. A low-voltage PPM is injected at the PPMIN pin. PPMIN is a high-impedance input that controls the PPM differential voltage on tip and ring. The PPM signal may be present at this pin at all times; however, PPM will only be transmitted to tip and ring during a PPM active mode. Activating or deactivating the PPMIN input will not change the state of the SLIC device. The SLIC may change states while the PPMIN input is active.

Design equations relating the magnitude of the PPM signal output at tip and ring to the PPM input signal at PPMIN and information on PPM cancellation are given in the Special Functions, Periodic Pulse Metering section of this data sheet.

No PPM shaping is done by the L9310 device. It is assumed that a shaped PPM input is presented to PPMIN.

Maximum allowed PPM and dc current limit are related by the overall drive capabilities of the tip and ring drive amplifiers. These amplifiers can support up to 70 mA dc current limit with a maximum 2.5 Vrms meter pulse signal at tip and ring. These amplifiers can support up to 45 mA dc current limit with a maximum 5 Vrms meter pulse signal at tip and ring.

If on-hook transmission of PPM is required, sufficient overhead to accommodate on-hook transmission must be programmed by the user at the OVH input. Overhead is not increased during a PPM active mode. Overhead may be changed during PPM active and PPM not active modes by a change to the voltage programmed at the OVH input. See the Overhead Voltage section of the dc Characteristics section for more detail.

Filtering of the meter pulse signal in the transmit direction may be necessary to prevent overload at the codec inputs. Note that PPMOUT is provided as a convenient point to perform rejection of the meter pulse. Via a resistor from PPMOUT to node ITR, a portion of the PPM signal that is injected to tip and ring is phase inverted and fed back to the transmit path to provide a hybrid cancellation of the meter pulse signal in the transmit direction.

This method of hybrid cancellation is adequate for 2.5 Vrms meter pulse. However, for higher-voltage meter pulse, such as 5 Vrms, additional filtering may be necessary. This may be done by a filter network at the TXN input.

Transmit and receive gains have been chosen to minimize the number of external components required in the SLIC-codec ac interface, regardless of the choice of codec.

The L9310 uses a voltage feed, current sense architecture; thus, the transmit gain is a transconductance. The L9310 transconductance is set via a single external resistor, and this device is designed for optimal performance with a transconductance set at 300 V/A.

The L9310 offers an option for a single-ended to differential receive gain of either 8 or 2. These options are mask programmable at the factory and are selected by choice of part number.

A receive gain of 8 is more appropriate when choosing a first-generation type codec where termination impedance, hybrid balance, and overall gains are set by external analog filters. The higher gain is typically required for synthesization of complex termination impedance.

A receive gain of 2 is more appropriate when choosing a third-generation type codec. Third-generation codecs will synthesize termination impedance, set hybrid balance, and set overall gains. To accomplish these functions, third-generation codecs typically have both analog and digital gain filters. For optimal signal-to-noise performance, it is best to operate the codec at a higher gain level. If the SLIC then provides a high gain, the SLIC output may be saturated, causing clipping distortion of the signal at tip and ring. To avoid this situation with a higher-gain SLIC, external resistor dividers are used. These external components are not necessary with the lower gain offered by the L9310.

The RCVP/RCVN SLIC inputs are floating inputs. If there is not feedback from RCVP/RCVN to VITR, RCVP/RCVN may be directly coupled to the codec output. If there is feedback, RCVP/RCVN must be ac-coupled to the codec output.

This device is packaged in a 44-pin PLCC surface-mount package.



## Architecture

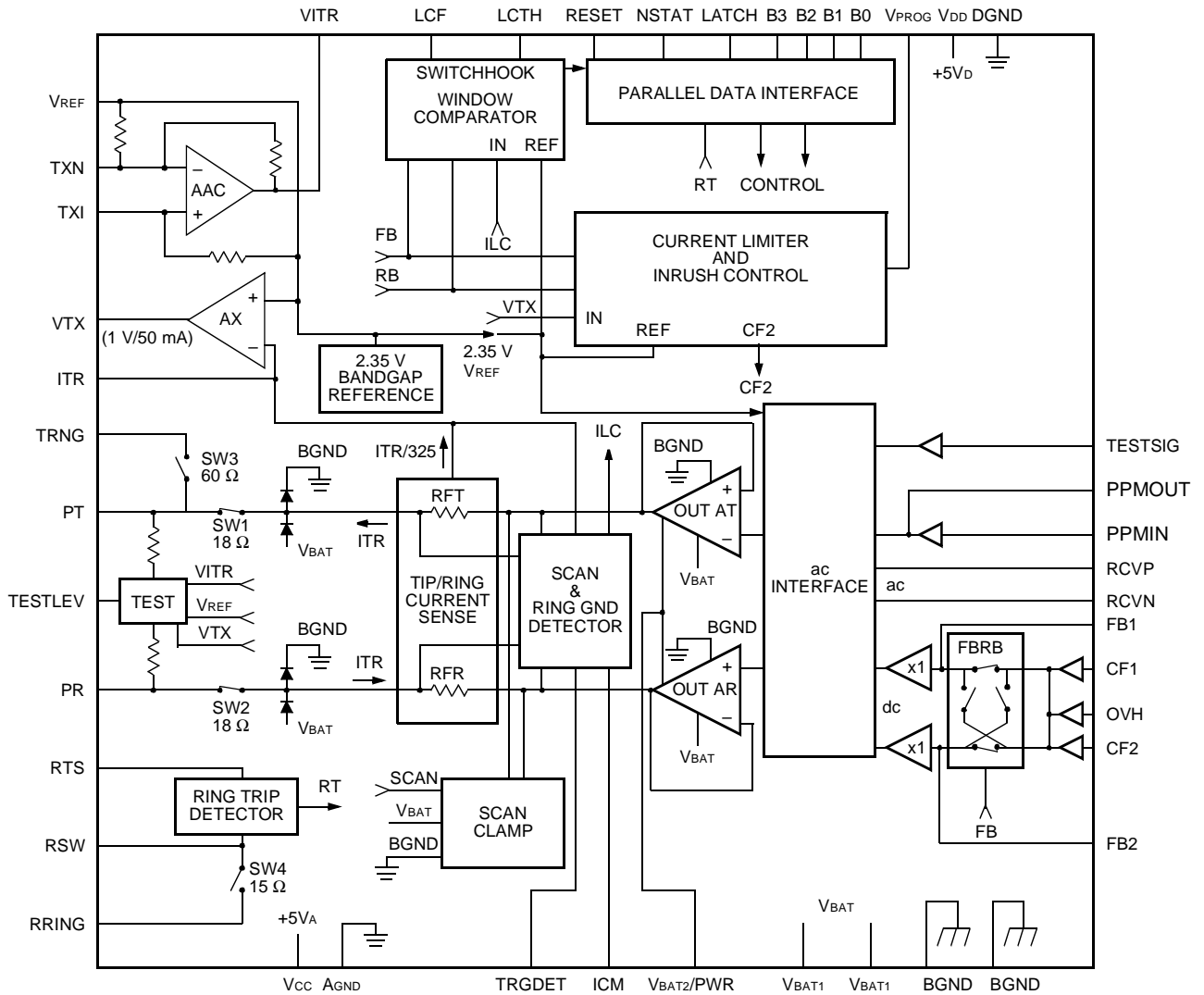

12-3523 (F)

Figure 1. Architecture Diagram

Architecture (continued)

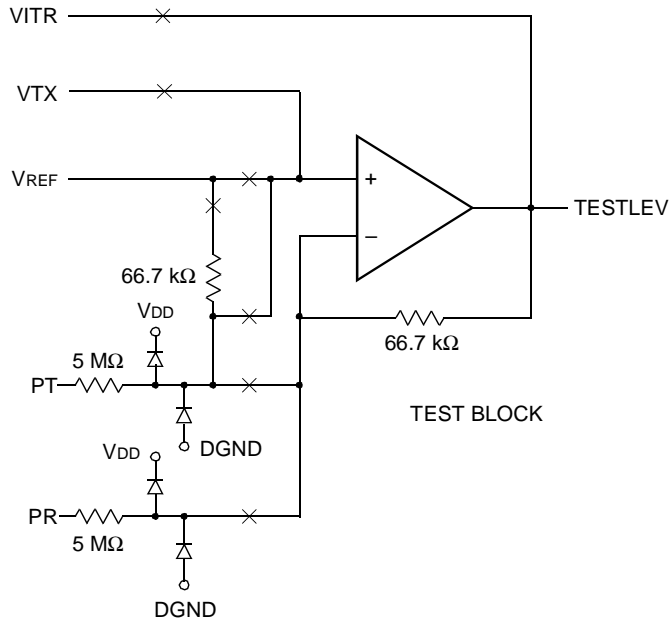

12-3525c (F)

Figure 2. Test Diagram

Pin Information

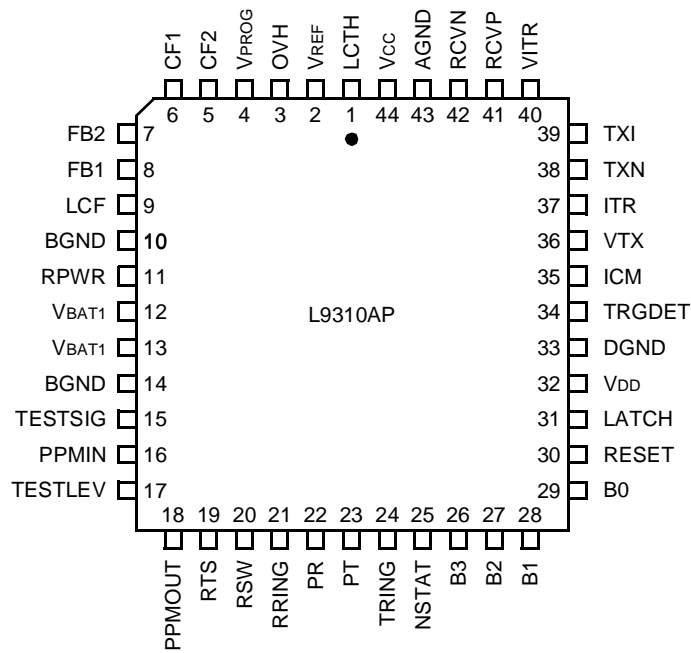

12-3522 (F)

Figure 3. 44-Pin PLCC

Pin Information (continued)

Table 1. Pin Descriptions

Pin	Symbol	Type	Name/Function
1	LCTH	I	<b>Loop Closure Program Input.</b> Connect a voltage source or ground, via a resistor, to this point to program the loop closure threshold.
2	V <sub>REF</sub>	O	<b>SLIC Internal Reference Voltage.</b> Output of internal 2.35 V SLIC reference voltage.
3	OVH	I	<b>Overhead Voltage Program Input.</b> Connect a voltage source to this point to program the overhead voltage. Voltage source may be external or derived via a resistor divider from V <sub>REF</sub> . A programmable external voltage source may be used to provide software control of the overhead voltage. If a resistor or voltage source is not connected, the overhead voltage will default to approximately 5.5 V (sufficient to pass 3.14 dBm in to 900 Ω). If the default overhead is desired, connect this pin to ground.
4	V <sub>PROG</sub>	I	<b>Current-Limit Program Input.</b> Connect a voltage source to this point to program the dc current limit. Voltage source may be external or derived via a resistor divider from V <sub>REF</sub> . A programmable external voltage source may be used to provide software control of the loop closure threshold.
5	CF2	—	<b>Filter Capacitor.</b> Connect a 0.1 μF capacitor from this node to ground for filtering.
6	CF1	—	<b>Filter Capacitor.</b> Connect a capacitor from this node to OVH to control the rate of change of the overhead voltage. If controlled overhead is not desired, leave this node open.
7	FB2	—	<b>Polarity Reversal Slowdown Capacitor.</b> Connect a capacitor from this node to ground to control the rate of battery reversal. If controlled battery reversal is not desired, leave pin is open.
8	FB1	—	<b>Polarity Reversal Slowdown Capacitor.</b> Connect a capacitor from this node to ground to control the rate of battery reversal. If controlled battery reversal is not desired, leave pin is open.
9	LCF	—	<b>Loop Closure Filter Capacitor.</b> PPM injection can cause false loop closure indication. Connect a capacitor from this node to V <sub>CC</sub> to filter the loop closure detector. If loop closure filtering is not required, leave this node open.
10	BGND	G	<b>Battery Ground.</b> Ground return for the battery supply.
11	RPWR	P	<b>Auxiliary Battery.</b> If a lower-voltage auxiliary battery is used, connect the auxiliary battery supply to this node. If a power control resistor is used, connect the power control resistor from this node to V <sub>BAT1</sub> . If no power control technique is used, connect this node to V <sub>BAT1</sub> .
12	V <sub>BAT1</sub>	P	<b>Office Battery Supply.</b> Negative high-voltage power supply.
13	V <sub>BAT1</sub>	P	<b>Office Battery Supply.</b> Negative high-voltage power supply.
14	BGND	G	<b>Battery Ground.</b> Ground return for the battery supply.
15	TESTSIG	I	<b>Test Input.</b> This input injects a test signal to the line when an appropriate test operational state is chosen. Connect this node to V <sub>REF</sub> if not used.
16	PPMIN	I	<b>Receive PPM Signal Input.</b> This high-impedance input controls the PPM differential voltage on tip and ring. The PPM signal may be present at this pin at all times; however, PPM will only be transmitted to tip and ring if the appropriate active-PPM state is chosen. ac couple PPM signal to this node. Connect this node to V <sub>REF</sub> if not used.

Pin Information (continued)

Table 1. Pin Descriptions (continued)

Pin	Symbol	Type	Name/Function
17	TESTLEV	O	<b>Test Level Output.</b> This output pin will provide a voltage that is proportional to either the dc line voltage, dc line current, ac line voltage, ac line current, or internal reference voltage, dependent upon which operational state is selected.
18	PPMOUT	O	<b>PPM Out.</b> Connect a resistor from this node to ITR for hybrid cancellation of meter pulse signal.
19	RTS	I	<b>Ring Trip Sense.</b> Sense input for the ring trip detector.
20	RSW	O	<b>Ring Lead Ringing Access Switch.</b> Ringing relay connects this pin to pin RRING. Connect this pin to pin PR through a 400 $\Omega$ current-limiting resistor.
21	RRING	I	<b>Ringing Access.</b> Input to solid-state ringing access switch. Connect to ringing generator.
22	PR	I/O	<b>Protected Ring.</b> The output of the ring driver amplifier and input to loop sensing connected through solid-state break switch. Connect to subscriber loop through overvoltage/current protection.
23	PT	I/O	<b>Protected Tip.</b> The output of the tip driver amplifier and input to loop sensing connected through solid-state break switch. Connect to subscriber loop through overvoltage/current protection.
24	TRING	O	<b>Tip Ringing Return.</b> Ring relay connects this pin to PT. Connect to ringing supply return.
25	NSTAT	O	<b>Loop Status.</b> The output of the loop status detector (loop start detector wired-OR with ring trip detector). This loop status supervision output is not controlled by the data latch.
26	B3	I	<b>Data Control Input.</b> See Table 2, Primary Control States and Table 3, Secondary Control States for details.
27	B2	I	<b>Data Control Input.</b> See Table 2, Primary Control States and Table 3, Secondary Control States for details.
28	B1	I	<b>Data Control Input.</b> See Table 2, Primary Control States and Table 3, Secondary Control States for details.
29	B0	I	<b>Data Control Input.</b> See Table 2, Primary Control States and Table 3, Secondary Control States for details.
30	RESET	I	<b>Reset.</b> A logic low will override the B[0:3] and LATCH inputs and reset the state of the SLIC to the disconnect state and the switch to the all-off state.
31	LATCH	I	<b>Latch Control Input.</b> Edge-level sensitive control for data latches.
32	V <sub>DD</sub>	P	<b>5 V Digital Power Supply.</b> 5 V supply for digital circuitry.
33	DGND	G	<b>Digital Ground.</b> Ground return for V <sub>DD</sub> current.
34	TRGDET	O	<b>Tip/Ring Ground Detect.</b> When high, this open collector output indicates the presence of a ring ground or a tip ground. This supervision output may be used in ground start, ground key, or common-mode fault detection applications. It has an internal pull-up.
35	ICM	I	<b>Common-Mode Current Sense.</b> To program tip or ring ground sense threshold, connect a resistor to ground and connect a capacitor to AGND to filter 50 Hz/60 Hz. If unused, the pin is connected to ground.
36	VTX	O	<b>Tip/Ring Voltage Output.</b> This output is a voltage that is directly proportional to the differential tip/ring current. A resistor from this node to ITR sets the device transimpedance. Gain shaping for termination impedance with a COMBO I codec is also achieved with a network from this node to ITR.

**Pin Information** (continued)

**Table 1. Pin Descriptions** (continued)

Pin	Symbol	Type	Name/Function
37	ITR	I	<b>Transmit Gain.</b> A current output which is proportional to the differential current flowing from tip to ring. Input to AX amplifier. Connect a resistor from this node to VTX to set transmit gain to 300 $\Omega$ . Hybrid reject of meter pulse is done by a resistor from this node to PPMOUT. Gain shaping for termination impedance with a COMBO I codec is also achieved with a network from this node to VTX.
38	TXN	I	<b>Transmit ac Input (Inverting).</b> For higher-voltage meter pulse signals (5 Vrms), connect a network to this node for meter pulse filtering. If lower-voltage meter pulse is used and meter pulse rejection is done via PPMOUT, this node is not used. This node has an internal connection to VREF; thus, it may be left floating if unused.
39	TXI	I	<b>Transmit ac Input (Noninverting).</b> Connect a 0.1 $\mu$ F capacitor from this pin to VTX for dc blocking.
40	VITR	O	<b>Transmit ac Output Voltage.</b> The output is a voltage that is directly proportional to the differential ac tip/ring current. This output is connected via a proper interface network to the codec.
41	RCVP	I	<b>Receive ac Signal Input (Noninverting).</b> This high-impedance input controls the ac differential voltage on tip and ring.
42	RCVN	I	<b>Receive ac Signal Input (Inverting).</b> This high-impedance input controls the ac differential voltage on tip and ring.
43	AGND	G	<b>Analog Ground.</b> Ground return for Vcc current.
44	Vcc	P	<b>5 V Analog Power Supply.</b> 5 V supply for analog circuitry.

## Operating States

### Input State Coding

State control is via a tiered logic system. The device must initially be set to a primary control state ( $B3 = 0$ ). This will set the operational state of the SLIC and switch. The secondary control table ( $B3 = 1$ ) is used to turn on the PPM amplifier or to turn on the test circuitry and enter a test state. The primary state of the device (the state of the SLIC and switch) will not change when entering a secondary control state.

Within the primary control table, each state will set the SLIC and the switch to a specific mode. The exception is the tip-amp and ring-amp states. The tip-amp and ring-amp states will change the configuration of the switches, but leave the state of the SLIC unchanged from the previous primary control mode.

Once a primary (device) control state is selected, the PPM or test circuitry can be activated via a secondary control state. Within the secondary control table, there are PPM active modes and test active modes. Upon entering a test active mode in the secondary control table, both TESTLEV output and TESTSIG input are active and the test switches set to the appropriate condition. (See Test Architecture Diagram, Figure 2.) An exception is the  $V_{REF}$  test active mode. Upon entering

$V_{REF}$ , only the TESTLEV output is active, and the internal (2.35 V typical) reference voltage appears at TESTLEV. In the  $V_{REF}$  mode, the TESTSIG input is deactivated.

Once PPM is on, the user may reverse the battery in the primary state table without turning off PPM. With PPM, if the user goes to the scan, ring, or disconnect mode in the primary table, PPM will be turned off.

Unlike PPM, the test feature, once on, will remain on if the user transitions to forward active, reverse active, scan, ring, or disconnect state in the primary state table.

PPM or test is deactivated by selecting PPM/test off in the secondary control table.

Data control is via a parallel latched data control scheme. Data latches are edge-level sensitive. Data is latched in when the LATCH control input goes low. Data must be set up 200 ns before LATCH goes low and held 50 ns after LATCH goes high. While LATCH is low, the user should not change the data control inputs at B0, B1, B2, and B3. The data control inputs at B0, B1, B2, and B3 may only be changed when LATCH is high. NSTAT supervision output is not controlled by the LATCH control input.

**Operating States** (continued)

**Input State Coding** (continued)

**Table 2. Primary Control States**

B3	B2	B1	B0	RESET	State
0	0	0	0	1	Scan
0	0	0	1	1	Powerup, forward battery
0	0	1	0	1	Powerup, reverse battery
0	0	1	1	1	Tip and ring amp
0	1	0	0	1	Ring
0	1	0	1	1	Tip amp
0	1	1	0	1	Ring amp
0	1	1	1	1	Disconnect, break before make
X	X	X	X	0	Disconnect, break before make

**Table 3. Secondary Control States**

B3	B2	B1	B0	Type	Active	State
1	0	0	0	Test	TESTLEV, TESTSIG	Tip/ring voltage
1	0	0	1	Test	TESTLEV, TESTSIG	Tip voltage
1	0	1	0	Test	TESTLEV, TESTSIG	Ring voltage
1	0	1	1	Test	TESTLEV, TESTSIG	VTX—current
1	1	0	0	Test	TESTLEV	V <sub>REF</sub>
1	1	0	1	Test	TESTLEV, TESTSIG	V <sub>ITR</sub> —current
1	1	1	0	PPM	PPMIN, PPMOUT	PPM On
1	1	1	1	PPM	PPM Off	PPM Off/TEST Off

**Table 4. Supervision Coding**

Pin NSTAT	Pin TRGDET
0 = off-hook or ring trip	0 = ring ground
1 = on-hook and no ring trip	1 = no ring ground

## State Definitions

### Primary Control Modes

#### Powerup, Forward Battery

- Normal talk and battery feed state.
- Pin PT is positive with respect to pin PR.
- All ac transmission and dc feed circuits are powered up.
- On-hook transmission is enabled.
- Thermal shutdown is active.
- Battery window comparator sense shutdown is on.
- Switch break switches (SW1 and SW2) are closed, and ring access switches (SW3 and SW4) are open.
- $V_{BAT1}$  is applied to tip and ring during on-hook conditions.
- Automatic battery switch selects  $V_{BAT1}$  or  $V_{BAT2}$  during off-hook conditions.
- All supervision circuits except for ring trip detector are active.
- Overhead is set via pin OVH.
- TESTLEV output is in the high-impedance mode, and TESTSIG input is off unless this feature is selected via the secondary control table.
- PPMOUT is in the high-impedance mode, and PPMIN input is off unless this feature is selected via the secondary control table.
- NSTAT represents the loop closure detector status.

#### Powerup, Reverse Battery

- Normal talk and battery feed state.
- Pin PR is positive with respect to pin PT.
- All ac transmission and dc feed circuits are powered up.
- On-hook transmission is enabled.
- Thermal shutdown is active.
- Battery window comparator sense shutdown is on.
- Switch break switches (SW1 and SW2) are closed, and ring access switches (SW3 and SW4) are open.
- $V_{BAT1}$  is applied to tip and ring during on-hook conditions.

- Automatic battery switch selects  $V_{BAT1}$  or  $V_{BAT2}$  under off-hook conditions.
- All supervision circuits except for ring trip detector are active.
- Overhead is set via pin OVH.
- TESTLEV output is in the high-impedance mode, and TESTSIG input is off unless this feature is selected via the secondary control table.
- PPMOUT is in the high-impedance mode, and PPMIN input is off unless this feature is selected via the secondary control table.
- NSTAT represents the loop closure detector status.

### Scan

- Scan clamp circuitry is active.
- Loop closure is active.
- All ac transmission, dc feed, and other supervision circuits, including ring trip, are shut down.
- PPM is powered down.
- Thermal shutdown is active.
- Battery window comparator sense shutdown is on.
- On-hook transmission is disabled.
- Pin PT is positive with respect to PR, and  $V_{BAT1}$  is applied to tip/ring.
- Switch break switches (SW1 and SW2) are closed, and ring access switches (SW3 and SW4) are open.
- When the scan clamp circuitry is on, overhead voltage is fixed and not controlled by OVH. Also the current limit is not the normal current limit set at  $V_{PROG}$ .
- NSTAT represents the loop closure detector status.

### Ground Start

- Tip amplifier is on, tip break switch is open.
- The device presents a high impedance ( $>100\text{ k}\Omega$ ) to pin PT and a current-limited battery ( $V_{BAT2}$ ) to PR.
- Common-mode current detector is on.
- Ring trip detector is off.
- Output TRGDET indicates current flowing in the ring lead.
- This is not a defined state in the primary control mode table. It is achieved via the powerup and the ring amp states in the primary control mode table.



## State Definitions (continued)

### Primary Control Modes (continued)

#### Ringing

- Switch break switches (SW1 and SW2) are open, and ring access switches (SW3 and SW4) are closed.
- Tip/ring drive amplifiers are powered down.
- Ring trip circuit is active.
- Loop supervision and common-mode current detectors are powered down.
- NSTAT represents the ring trip detector status.

#### Disconnect—Break Before Make

- The tip and ring amplifiers are turned off to conserve power.
- Break switches (SW1 and SW2) are open, and ring access switches (SW3 and SW4) are open. This mode is also used as a transitional mode to achieve break-before-make switching from the power ring to active or scan mode.
- All supervision circuits are powered down; NSTAT overrides the actual loop condition and is forced high (on-hook).

#### Tip Amp

- Tip side break switch is closed, and ring side break switch and ring access switches are open.
- SLIC mode is unaffected by reconfiguring the ring relay via this mode; thus, SLIC will remain in the mode it was in prior to selecting this mode.

#### Ring Amp

- Ring side break switch is closed; tip side break switch and ring access switches are open.
- SLIC mode is unaffected by reconfiguring the ring relay via this mode; thus, SLIC will remain in the mode it was in prior to selecting this mode.

#### Tip and Ring Amp

- Tip and ring side break switches are open; ring access switches are open.
- SLIC mode is unaffected by reconfiguring the break switches via this mode; thus, SLIC will remain in the mode it was in prior to selecting this mode.
- This is the calibration mode for differential and single-ended tip/ring current measurements.

#### Reset

- Selection of device reset via the RESET pin will set the device into the disconnect break-before-make state.

### Secondary Control Mode States

#### Voltage: Tip to Ground

- A voltage proportional to the tip to ground voltage appears at the TESTLEV output.
- TESTSIG input is on.
- Customer applies ac test tone or  $V_{REF}$  to TESTSIG to select an ac or dc measurement.

#### Voltage: Ring to Ground

- A voltage proportional to the ring to ground voltage appears at the TESTLEV output.
- TESTSIG input is on.
- Customer applies ac test tone or  $V_{REF}$  to TESTSIG to select an ac or dc measurement.

#### Voltage: Tip to Ring

- A voltage proportional to the differential tip to ring voltage appears at the TESTLEV output.
- TESTSIG input is on.
- Customer applies ac test tone or  $V_{REF}$  to TESTSIG to select an ac or dc measurement.

## State Definitions (continued)

### Secondary Control Mode States (continued)

#### Current: Tip to Ring—VTX

- A voltage proportional to the ac, plus dc tip to ring differential current, tip to ground current, or ring to ground current appears at the TESTLEV output. Use this state for dc measurements.
- Choice is determined by primary control mode table.
- Differential current is selected by choosing powerup forward or reverse from the primary control mode table.
- Tip to ground or ring to ground current is selected by first choosing powerup forward or reverse from the primary mode table, and then choosing tip amp or ring amp from the primary mode table.
- TESTSIG input is on.
- Customer applies ac test tone or  $V_{REF}$  to select an ac or dc measurement.

#### Current: Tip to Ring—VITR

- A voltage proportional to the ac tip to ring differential current, tip to ground current, or ring to ground currents, appears at TESTLEV output. Use this state for ac measurements.
- Choice is determined by primary control mode table.
- Differential current is selected by choosing powerup forward or reverse from the primary control mode table.
- Tip to ground or ring to ground current is selected by first choosing powerup forward or reverse from the primary mode table, and then choosing tip amp or ring amp from the primary mode table.
- TESTSIG input is on.
- Customer applies ac test tone or  $V_{REF}$  to select an ac or dc measurement.

### Reference Voltage

- A voltage proportional to the internal dc reference voltage  $V_{REF}$  appears at the TESTLEV output.
- TESTSIG input is off.
- This is the calibration state for voltage measurements.

### PPM On

- The PPMIN input is activated and the PPM signal at PPMIN is transmitted to tip and ring.
- Device mode per primary control mode table. Once PPM is active, transition to the scan, disconnect, or ring modes in the primary state table will deactivate PPMIN. Transition to forward battery, reverse battery, ring amp, or tip amp state will not deactivate PPMIN.

### PPM Off/TEST Off

- The PPMIN input is deactivated and the PPM signal at PPMIN does not appear at tip and ring.
- PPMOUT is high impedance.
- Device mode is per primary control mode table.
- The TESTSIG input is deactivated.
- TESTLEV output is high impedance.
- Device mode is per primary control mode table.

## Special States

### Thermal Shutdown

- Not controlled via truth table inputs.
- This mode is caused by excessive heating of the device, such as may be encountered in an extended power cross situation.
- Upon reaching the thermal shutdown temperature, the device will enter an all-off mode.
- Upon cooling, the device will re-enter the state it was in prior to thermal shutdown.
- Hysteresis is built in to prevent oscillation. In this mode, supervision output NSTAT is forced low (off-hook) regardless of loop status or if the disconnect logic state is selected.

## State Definitions (continued)

### Special States (continued)

#### Battery Out of Range

- Not controlled via truth table inputs.
- This mode is caused by a battery out of range; that is, the battery voltage rising above or below a specified threshold.
- Upon reaching the specified high or low battery voltage, the device will enter an all-off mode.
- Upon the battery returning to the specified normal operating range, the device will re-enter the state it was in prior to the low battery shutdown.
- Hysteresis is built in to prevent oscillation. In this mode, supervision output NSTAT is forced low (off-hook) regardless of loop status or if the disconnect logic state is selected.

## Absolute Maximum Ratings (at TA = 25 °C)

Stresses in excess of the absolute maximum ratings can cause permanent damage to the device. These are absolute stress ratings only. Functional operation of the device is not implied at these or any other conditions in excess of those given in the operational sections of the data sheet. Exposure to absolute maximum ratings for extended periods can adversely affect device reliability.

Parameter	Symbol	Min	Max	Unit
5 V dc Supplies (V <sub>CC</sub> + V <sub>DD</sub> )	—	-0.5	7.0	V
High Office Battery Supply (V <sub>BAT1</sub> )	—	-75	0.5	V
Auxiliary Office Battery Supply (V <sub>BAT2</sub> )	—	—	V <sub>BAT1</sub> to 0.5 V	V
Ringing Voltage	—	—	110	V <sub>rms</sub>
Logic Input Voltage	—	-0.5	V <sub>CC</sub> + 0.5 V	V
Maximum Junction Temperature	—	—	165	°C
Storage Temperature Range	—	-40	125	°C
Relative Humidity Range	—	5	95	%
Switch 1, 2, 3; Pole to Pole	—	—	320	V
Switch 4; Pole to Pole	—	—	465	V
Switch Input to Output	—	—	320	V

Note: The IC can be damaged unless all ground connections are applied before, and removed after, all other connections. Furthermore, when powering the device, the user must guarantee that no external potential creates a voltage on any pin of the device that exceeds the device ratings. For example, inductance in a supply lead could resonate with the supply filter capacitor to cause a destructive overvoltage.

## Electrical Characteristics

In general, minimum and maximum values are testing requirements. However, some parameters may not be tested in production because they are guaranteed by design and device characterization. Typical values reflect the design center or nominal value of the parameter; they are for information only and are not a requirement. Minimum and maximum values apply across the entire temperature range (–40 °C to +85 °C) and entire battery range (–36 V to –70 V). Unless otherwise specified, typical is defined as 25 °C,  $V_{CC} = V_{DD} = 5.0$ ,  $V_{BAT1} = -48$  V,  $V_{BAT2} = -25$  V. Positive currents flow into the device.

**Table 5. Device Operating Conditions and Powering**

Parameter	Min	Typ	Max	Unit
Temperature Range	–40	—	85	°C
Humidity Range	5	—	95*	%RH
$V_{BAT1}$ Operational Range	–36	–48	–72	V
$V_{BAT2}$ Operational Range	–19	–25	$V_{BAT1}$	V
5 V dc Supplies ( $V_{CC}$ , $V_{DD}$ )	4.75	5.0	5.25	V
Supply Currents, Scan State No Loop Current, $V_{BAT} = -48$ V, $V_{CC} = V_{DD} = 5$ V:				
$I_{VCC+VDD}$	—	2	2.5	mA
$I_{VBAT1}$	—	100	200	μA
Power Dissipation	—	15	22	mW
Supply Currents, Forward/Reverse Active No Loop Current, with On-hook Transmission, PPM Not Active, Test Not Active, $V_{BAT} = -48$ V, $V_{CC} = V_{DD} = 5$ V:				
$I_{VCC+VDD}$	—	6	6.5	mA
$I_{VBAT1}$	—	1.1	1.4	mA
Power Dissipation	—	83	100	mW
Supply Currents, Forward Disconnect, $V_{BAT} = -48$ V, $V_{CC} = V_{DD} = 5$ V:				
$I_{VCC+VDD}$	—	1.2	1.85	mA
$I_{VBAT1}$	—	65	275	μA
Power Dissipation	—	9	22.5	mW
Supply Currents, Ring State, No Loop Current, $V_{BAT} = -48$ V, $V_{CC} = V_{DD} = 5$ V, $V_{RING} = 80$ Vrms:				
$I_{VCC+VDD}$	—	4	—	mA
$I_{VBAT1}$	—	200	—	μA
$I_{RING}$ Generator	—	500	—	μA
Power Dissipation	—	70	—	mW
Power Adders, $V_{CC} = V_{DD} = 5$ V, Power for PPM and Test Amplifiers Drawn Only from 5 V Supply:				
PPM	—	1	—	mW
Test	—	5	—	mW
PSRR 500 Hz—3000 Hz:				
$V_{BAT1}$ , $V_{BAT2}$	45	—	—	dB
$V_{CC}$	30	—	—	dB
Thermal Protection Shutdown ( $T_{TSD}$ )	150	165	—	°C

\* Not to exceed 26 grams of water per kilogram of dry air.

## Electrical Characteristics (continued)

### Ring Trip Detector

Table 6. Ring Trip Detector

Parameter	Min	Typ	Max	Unit
Voltage at Input that will Cause Ring Trip After Appropriate Zero Crossings	±2.5	±3	±3.5	V
Voltage at Input that will Cause Immediate Ring Trip	±12	±15	±18	V
Ringing Source <sup>1</sup> :				
Frequency (f)	19	20	28	Hz
dc Voltage	-39.5	—	-57	V
ac Voltage	60	—	105	Vrms
Ring Trip (NDET = 0) <sup>2, 3</sup> :				
Loop Resistance	2000	—	—	Ω
Trip Time	—	—	200	ms
NDET Valid	—	—	80	ms

- The ringing source may be either of the following:
  - The ringing source consists of the ac and dc voltages added together (battery-backed ringing); the ringing return is ground.
  - The ringing source consists of only the ac voltage (earth-backed ringing); the ringing return is the dc voltage.
- NDET must also indicate ring trip when the ac ringing voltage is absent (<5 Vrms) from the ringing source.
- Pretrip ringing must not be tripped by a 10 kΩ resistor in parallel with an 8 μF capacitor applied across tip and ring.

### PPM

Table 7. PPM

Parameter	Min	Typ	Max	Unit
PPM Source <sup>1</sup> :				
Frequency (f1)	11.88	12	12.12	kHz
Frequency (f2)	15.80	16	16.20	kHz
Input Signal	—	—	1.0	Vrms
Signal Gain (from PPMIN to amplifier outputs)	9	10	11	—
Harmonic Distortion <sup>2</sup>	—	—	5	%
Isolation (nontest states)	65	—	—	dB
Isolation (test modes)	50	—	—	dB

- PPM signal should be ac coupled into PPMIN.
- This parameter is not tested in production, it is guaranteed by design and characterization.

## Electrical Characteristics (continued)

### Test

**Table 8. ac Test Source**

Parameter	Min	Typ	Max	Unit
Test Source <sup>1, 2</sup> :				
Frequency (f1)	—	—	100	kHz
Signal Gain (TESTSIG to amplifier outputs) $V_{TESTSIG} = 0.35$ V	—	10	—	—
Signal Gain Voltage Coefficient	—	1.27	—	1/V
Input Signal	0	—	1.25	Vrms
Harmonic Distortion <sup>3</sup>	—	—	5	%

1. ac test signal should be ac coupled into TESTSIG.

2. A pull-down resistor to  $V_{REF}$  should be connected to TESTSIG.

3. This parameter is not tested in production, it is guaranteed by design and characterization.

**Table 9. Test Sense**

Parameter	Min	Typ	Max	Unit
Single-ended Voltage Gain $\pm 10$ V on Tip/Ring	—	1/75	—	—
Differential Voltage Gain $\pm 10$ V on Tip/Ring	—	1/75	—	—
Voltage Gain Accuracy (single-ended or differential)	-3.5	—	3.5	%
Voltage Coefficient	—	0.01 <sup>1</sup>	—	%/V
Current Gain at VTX (dc) Differential	19.6	20	20.4	V/A
Current Gain at VTX (dc) Single-ended	9.8	10	10.2	V/A
Current Gain at VITR (ac) Differential	291	300	309	V/A
Current Gain at VITR (ac) Single-ended	145.5	150	154.5	V/A
Overload at VTX <sup>2</sup>	$\pm 105$	—	—	mA
Overload at VITR <sup>2</sup>	$\pm 7$	—	—	mA
$V_{REF}$	—	2.35	—	V
$V_{REF}$ Accuracy	-5	—	5	%
TESTLEV Offset Relative to $V_{REF}$	-40	—	40	mV
TESTLEV Amplifier				
Output Voltage Swing	AGND + 0.35	—	$V_{CC} - 0.4$	V
Input Voltage Swing	AGND + 0.35	—	$V_{CC} - 1.0$	V

1. This is the voltage coefficient with respect to tip/ring voltage. See Table 21 TESTLEV Output Options (Tip-to-Ring, Tip-to-Ground, and Ring-to-Ground equations) for application of this parameter.

2. This parameter is not tested in production, it is guaranteed by design and characterization.

**Electrical Characteristics** (continued)

**SLIC Two-Wire Port**

**Table 10. SLIC Two-Wire Port**

Parameter	Min	Typ	Max	Unit
PT and PR Drive Current = dc + Longitudinal + Signal Currents + PPM	105	—	—	mA <sub>peak</sub>
Signal Current	10	—	—	mArms
Longitudinal Current Capability per Wire (longitudinal current is independent of dc loop current)	8.5	15	—	mArms
PPM Signal Current (2.5 V <sub>rms</sub> max into 200 Ω ac)	12.5	—	—	mArms
PPM Signal Current (5 V <sub>rms</sub> max into 200 Ω ac)	25	—	—	mArms
dc Active Mode Loop Current – I <sub>LIM</sub> (R <sub>LOOP</sub> = 100 Ω): Programming Range (2.5 V <sub>rms</sub> max into 200 Ω ac) Voltage at V <sub>PROG</sub>	10 0.2	— —	70 1.4	mA V
dc Active Mode Loop Current – I <sub>LIM</sub> (R <sub>LOOP</sub> = 100 Ω): Programming Range (5 V <sub>rms</sub> max into 200 Ω ac) Voltage at V <sub>PROG</sub>	10 0.2	— 0	45 0.9	mA V
dc Current-limit Variation: V <sub>PROG</sub> = 0.8 V (I <sub>LIMIT</sub> = 40 mA)	—	5	—	%
Loop Resistance Range (from PT/PR) (3.17 dBm overload into 600 Ω): I <sub>LOOP</sub> = 20 mA at V <sub>BAT1</sub> = –48 V	1900	—	—	Ω
V <sub>REF</sub>	2.23	2.35	2.47	V
Offset at V <sub>PROG</sub>	–40	—	40	mV
dc Feed Resistance (includes internal SLIC dc resistance and break switch resistance)	50	75	110	Ω
dV/dT Sensitivity at PT/PR	—	200	—	V/μs
Ground Start State PT Resistance	100	—	—	kΩ
Powerup Open Loop Voltages (V <sub>BAT1</sub> = –48 V): Forward/Reverse Active Mode  PT – PR  – V <sub>BAT1</sub> (programming range) Voltage at OVH (programming voltage) Forward/Reverse Active Mode  PT – PR  – V <sub>BAT1</sub> (OVH to GND) Common Mode	5.5 0 5.5 —	— — 6.1 (V <sub>BAT1</sub> + 1)/2	15 1.9 — —	V V V V

**Electrical Characteristics** (continued)

**SLIC Two-Wire Port** (continued)

**Table 10. SLIC Two-Wire Port** (continued)

Parameter	Min	Typ	Max	Unit
Powerup Open Loop Voltages: Scan Mode  PT – PR  – V <sub>BAT1</sub>	0	—	13.5	V
Loop Closure Threshold: Voltage at LCTH	0	—	V <sub>REF</sub>	V
Loop Closure Threshold Hysteresis	—	20	—	%
Ground Key/Ground Start: Gain ICM to TRGDET	—	1	—	μA/mA
Common-mode Detector Threshold	5	—	10	mA
Longitudinal to Metallic Balance at PT/PR* (Test Method: Q552 [11/96] Section 2.1.2, <i>IEEE</i> <sup>†</sup> Std. 455):				
300 Hz to 600 Hz	54	—	—	dB
600 Hz to 3.4 kHz	54	—	—	dB
Metallic to Longitudinal (harm) Balance: 200 Hz to 4000 Hz	40	—	—	dB

\* Guarantees 46 dB from 300 Hz to 3.4 kHz, with 50 Ω, 1% protection, resistors into a complex resistive termination impedance.

† *IEEE* is a registered trademark of The Institute of Electrical and Electronics Engineers, Inc.



**Electrical Characteristics** (continued)

**Analog Pin Characteristics**

**Table 11. Analog Pin Characteristics**

Parameter	Min	Typ	Max	Unit
TXN and TXI (input impedance)	75	105	—	kΩ
V <sub>PROG</sub> Input Bias Current* (current flow out of pin)	—	-50	-250	nA
V <sub>OH</sub> Input Bias Current* (current flow out of pin)	—	-50	-250	nA
LCTH Input Bias Current* (+ current flows into pin)	—	50	250	nA
<b>VTX:</b>				
Output Offset	—	—	±40	mV
Output Drive Current	±1	—	—	mA
Output Voltage Swing (±1 mA load):				
Maximum	AGND	—	V <sub>CC</sub>	V
Minimum	AGND + 0.35	—	V <sub>CC</sub> - 0.4	V
Output Short-circuit Current	—	—	±50	mA
Output Load Resistance*	10	—	—	kΩ
Output Load Capacitance*	—	50	—	pF
<b>VITR:</b>				
Output Offset	—	—	±100	mV
Output Drive Current	±1	—	—	mA
Output Voltage Swing (±1 mA load):				
Maximum	AGND	—	V <sub>CC</sub>	V
Minimum	AGND + 0.35	—	V <sub>CC</sub> - 0.4	V
Output Short-circuit Current	—	—	±50	mA
Output Load Resistance*	10	—	—	kΩ
Output Load Capacitance*	—	50	—	pF
<b>RCVN and RCVP:</b>				
Input Voltage Range (V <sub>CC</sub> = 5.0 V)	0	—	V <sub>CC</sub> - 0.5	V
Input Bias Current	—	—	±1.5	μA

\* This parameter is not tested in production. It is guaranteed by design and device characterization.

**Electrical Characteristics** (continued)

**ac Feed Characteristics**

**Table 12. ac Feed Characteristics**

Parameter	Min	Typ	Max	Unit
ac Termination Impedance <sup>1</sup>	150	600	1400	Ω
Total Harmonic Distortion (200 Hz—4 kHz) <sup>2</sup> :				
Off-hook	—	—	0.3	%
On-hook	—	—	1.0	%
Transmit Gain <sup>3</sup> f = 1004 Hz, 1020 Hz: PT/PR Current to VTR	-291	-300	-309	V/A
Receive Gain, f = 1004 Hz, 1020 Hz Open Loop:				
RCVP or RCVN to PT—PR (gain = 8)	7.76	8	8.24	—
RCVP or RCVN to PT—PR (gain = 2)	1.94	2	2.06	—
ac Feed Resistance (includes internal SLIC ac resistance and break switch resistance)	50	75	110	Ω
Gain vs. Frequency (transmit and receive) <sup>2</sup> 900 Ω = 2.16 μF Termination, 1004 Hz Reference:				
200 Hz—300 Hz	-0.3	0	0.05	dB
300 Hz—3.4 kHz	-0.05	0	0.05	dB
3.4 kHz—20 kHz	-3.0	0	0.05	dB
20 kHz—266 kHz	—	—	2.0	dB
Gain vs. Level (transmit and receive) <sup>2</sup> 0 dBV Reference: -55 dB to +3.0 dB	-0.05	0	0.05	dB
Idle-channel Noise (tip/ring) 600 Ω Termination:				
Psophometric	—	-82	-77	dBmp
C-Message	—	8	13	dBnC
3 kHz Flat	—	—	20	dBn
Idle-channel Noise (VTX) 600 Ω Termination:				
Psophometric	—	-82	-77	dBmp
C-Message	—	8	13	dBnC
3 kHz Flat	—	—	20	dBn

1. Set externally either by discrete external components or a third- or fourth-generation codec. Any complex impedance  $R1 + R2 \parallel C$  between 150 Ω and 1400 Ω can be synthesized.
2. This parameter is not tested in production. It is guaranteed by design and device characterization.
3. VTR transconductance depends on the resistor from ITR to VTX. This gain assumes an ideal 6.34 kΩ, the recommended value. Positive current is defined as the differential current flowing from PT to PR.

**Electrical Characteristics** (continued)

**Logic Inputs and Outputs,  $V_{DD} = 5.0\text{ V}$**

**Table 13. Logic Inputs and Outputs**

Parameter	Symbol	Min	Typ	Max	Unit
Input Voltages:					
Low Level	$V_{IL}$	-0.5	0.4	0.7	V
High Level	$V_{IH}$	2.0	2.4	$V_{DD}$	V
Input Current:					
Low Level ( $V_{DD} = 5.25\text{ V}$ , $V_I = 0.4\text{ V}$ )	$I_{IL}$	—	—	$\pm 50$	$\mu\text{A}$
High Level ( $V_{DD} = 5.25\text{ V}$ , $V_I = 2.4\text{ V}$ )	$I_{IH}$	—	—	$\pm 50$	$\mu\text{A}$
Output Voltages (CMOS):					
Low Level ( $V_{DD} = 4.75\text{ V}$ , $I_{OL} = 180\ \mu\text{A}$ )	$V_{OL}$	0	0.2	0.4	V
High Level ( $V_{DD} = 4.75\text{ V}$ , $I_{OH} = -20\ \mu\text{A}$ )	$V_{OH}$	2.4	—	$V_{CC}$	V

**Timing Requirements**

**Table 14. Timing Requirements**

Parameter	Symbol	Min	Typ	Max	Unit
Minimum Setup Time from B0, B1, B2, B3 to LATCH	$t_{SU}$	200	—	—	ns
Minimum Hold Time from LATCH to B0, B1, B2, B3	$t_{HL}$	50	—	—	ns

Data control is via a parallel latched data control scheme. Data latches are edge-level sensitive. Data is latched in when the LATCH control input goes low. Data must be set up  $t_{SU}$  ns before LATCH goes low and held  $t_{HL}$  ns after LATCH goes high. While LATCH is low, the user should not change the data control inputs at B0, B1, B2, and B3. The data control inputs at B0, B1, B2, and B3 may only be changed when LATCH is high. NSTAT supervision output is not controlled by the LATCH control input.

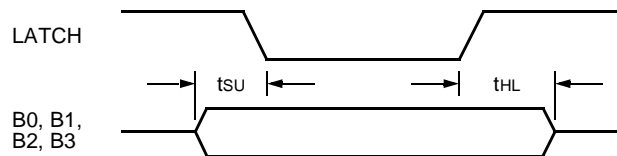

12-3526(F)

**Figure 4. Timing Requirements**

**Electrical Characteristics** (continued)

**Switch Characteristics**

**Table 15. Break Switches (SW1, 2)**

Parameter	Min	Typ	Max	Unit
Off State:				
Maximum Differential Voltage	—	—	±320 <sup>1</sup>	V
dc Leakage Current (V <sub>sw</sub> = ±320 V)	—	—	±20	µA
On State (see On-State I-V Switch Characteristics section):				
Resistance	—	18	28	Ω
Maximum Differential Voltage (V <sub>MAX</sub> ) <sup>2</sup>	—	—	320	V
Foldback Voltage Breakpoint 1 (V1)	72	—	—	V
Foldback Voltage Breakpoint 2 (V2)	V1 + 0.5	—	—	V
dc Current Limit 1 (I <sub>LIMIT1</sub> )	105	250	450	mA
dc Current Limit 2 (I <sub>LIMIT2</sub> )	2	—	—	mA
Dynamic Current Limit 10 x 700 µs, 1000 V Applied Surge T < 0.5 µs	—	2.5	—	A
dV/dT Sensitivity <sup>2, 3</sup>	—	200	—	V/µs

1. At 25 °C, maximum voltage rating has a temperature coefficient of 0.167 V/°C.

2. This parameter is not tested in production. It is guaranteed by design and device characterization.

3. Applied voltage is 100 Vp-p square wave at 100 Hz to measure dV/dT sensitivity.

**Table 16. Ring Return Switch (SW3)**

Parameter	Min	Typ	Max	Unit
Off State:				
Maximum Differential Voltage	—	—	±320 <sup>1</sup>	V
dc Leakage Current (V <sub>sw</sub> = ±320 V)	—	—	±20	µA
On State (see On-State Switch I-V Characteristics section):				
Resistance	—	60	100	Ω
Maximum Differential Voltage (V <sub>MAX</sub> ) <sup>2</sup>	—	—	130	V
dc Current Limit	—	200	—	mA
Dynamic Current Limit 10 x 700 µs, 1000 V Applied Surge T = 0.5 µs	—	2.5	—	A
dV/dT Sensitivity <sup>2, 3</sup>	—	200	—	V/µs

1. At 25 °C, maximum voltage rating has a temperature coefficient of 0.167 V/°C.

2. This parameter is not tested in production. It is guaranteed by design and device characterization.

3. Applied voltage is 100 Vp-p square wave at 100 Hz to measure dV/dT sensitivity.

**Electrical Characteristics** (continued)

**Switch Characteristics** (continued)

**Table 17. Ringing Access Switch (SW4)**

Parameter	Min	Typ	Max	Unit
Off State:				
Maximum Differential Voltage	—	—	±475	V
dc Leakage Current ( $V_{sw} = \pm 475$ V) (pole to pole)	—	—	±20	µA
Isolation	—	—	±320	V
On State (see On-State Switch I-V Characteristics section):				
Resistance	—	—	15	Ω
Voltage	—	—	3	V
Steady-state Current <sup>1</sup>	—	—	150	mA
Surge Current (10 x 700 µs pulse) <sup>2</sup>	—	—	2	A
Release Current	—	500	—	µA
dV/dT Sensitivity <sup>2, 3</sup>	—	200	—	V/µs

1. Choice of secondary protector and feed resistor should ensure these ratings are not exceeded. A minimum 400 Ω feed resistor is recommended.
2. This parameter is not tested in production. It is guaranteed by design and device characterization.
3. Applied voltage is 100 Vp-p square wave at 100 Hz to measure dV/dT sensitivity.

**On-State Switch I-V Characteristics**

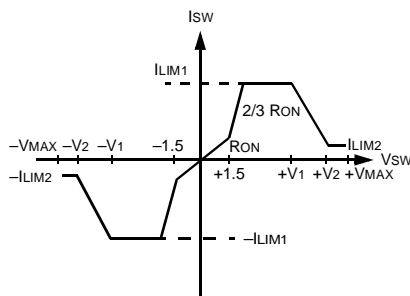

A. Line Break Switch SW1, SW2 5-5990.c(F)

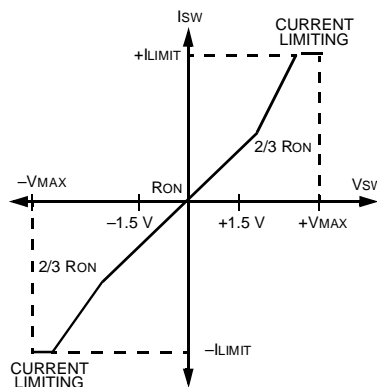

B. Ring Return SW3 12-3291.a(F)

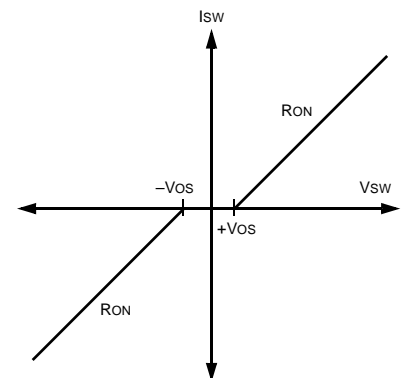

C. Ring Access SW4 12-3292.a(F)

**Figure 5. On-State Switch I-V Characteristics**

Test Configurations

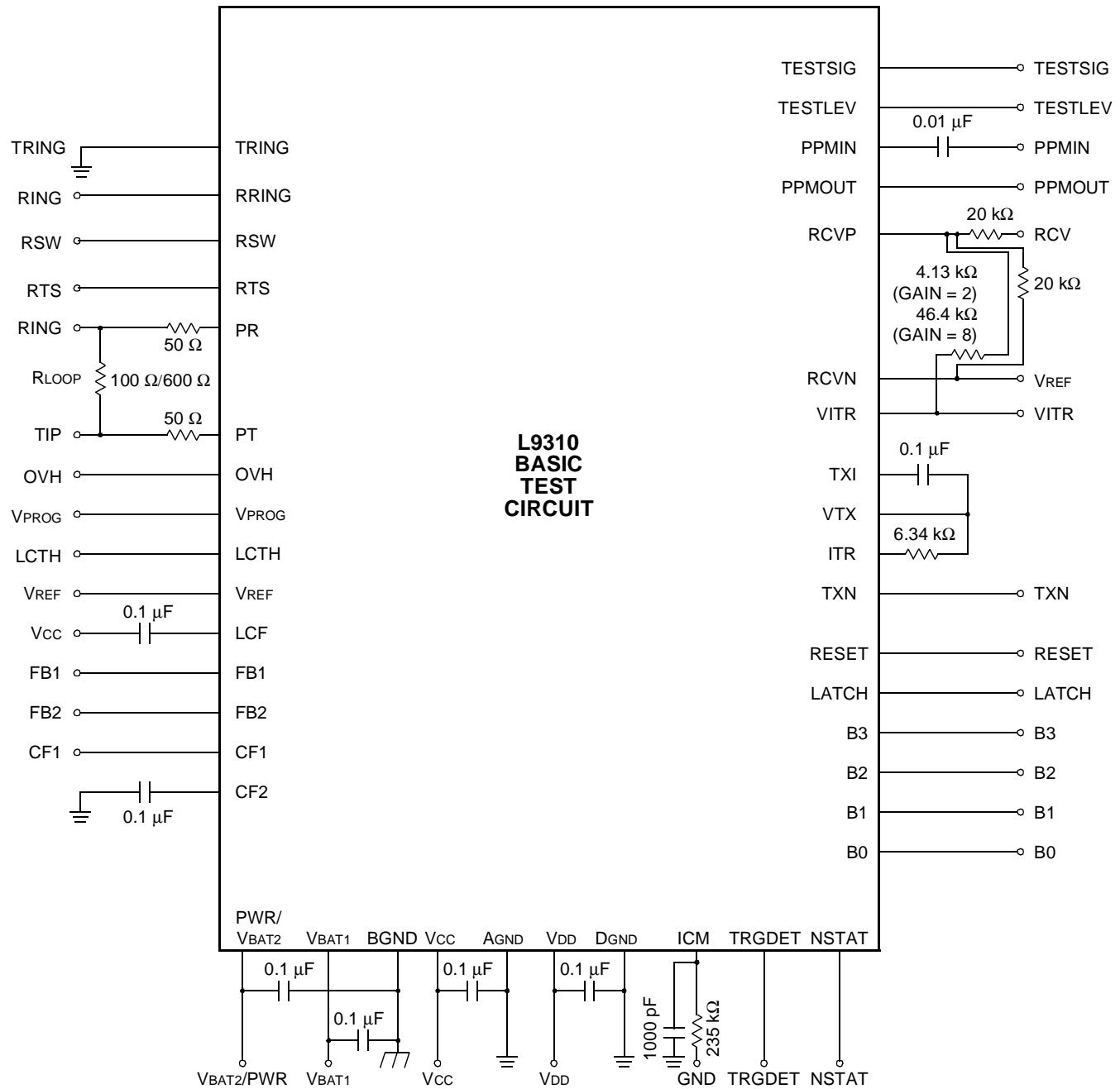

12-3524H(F)

Figure 6. Basic Test Circuit

Test Configurations (continued)

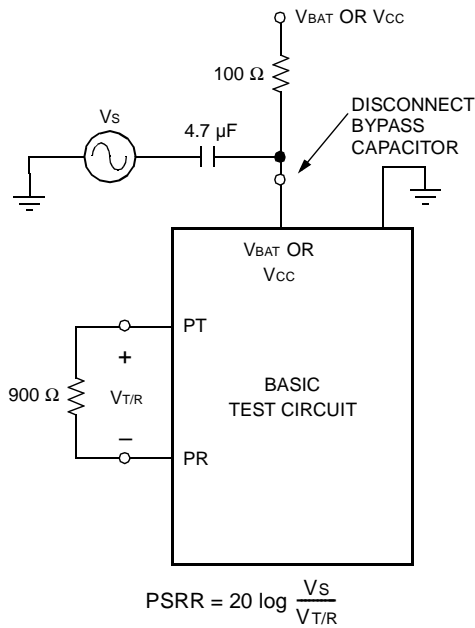

$$PSRR = 20 \log \frac{V_S}{V_{T/R}}$$

12-2582 (F)

Figure 7. Metallic PSRR

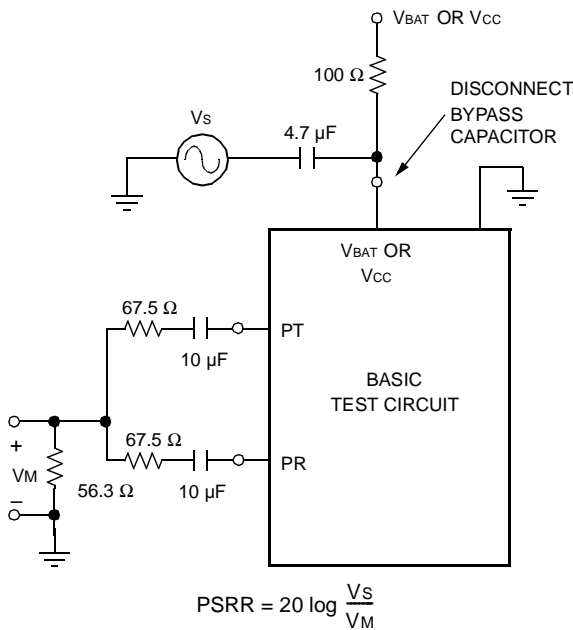

$$PSRR = 20 \log \frac{V_S}{V_M}$$

12-2583 (F)

Figure 8. Longitudinal PSRR

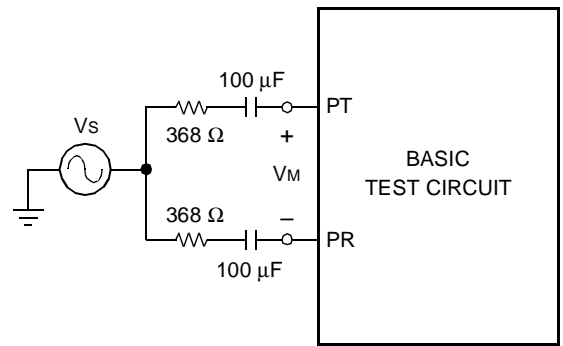

$$LONGITUDINAL \text{ BALANCE} = 20 \log \frac{V_S}{V_M}$$

ANSI/IEEE STANDARD 455-1985

12-2584 (F)

Figure 9. Longitudinal Balance

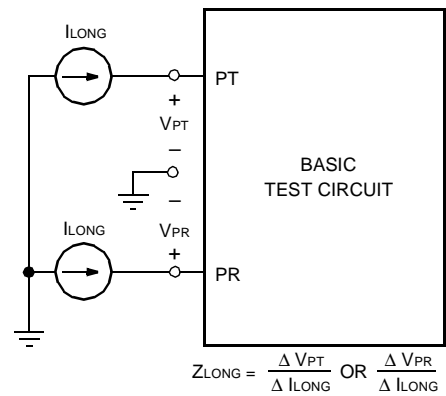

$$Z_{LONG} = \frac{\Delta V_{PT}}{\Delta I_{LONG}} \text{ OR } \frac{\Delta V_{PR}}{\Delta I_{LONG}}$$

12-2585 (F)

Figure 10. Longitudinal Impedance

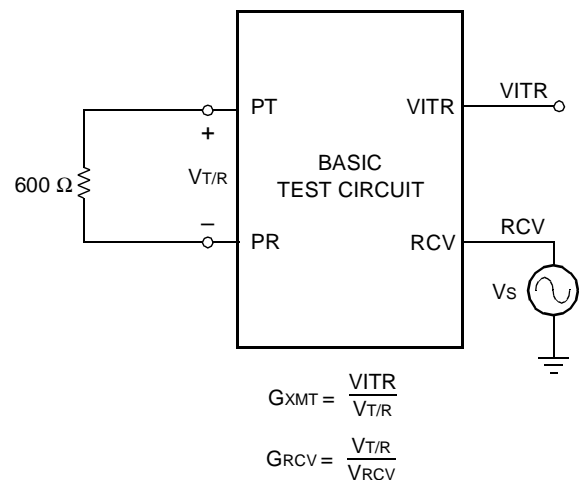

$$G_{XMT} = \frac{V_{ITR}}{V_{T/R}}$$

$$G_{RCV} = \frac{V_{T/R}}{V_{RCV}}$$

12-2587.g (F)

Figure 11. ac Gains

\* ANSI is a registered trademark of the American National Standards Institute, Inc.

## Applications

### dc Characteristics

#### Power Control

Under normal device operating conditions, thermal design must ensure that the device temperature does not rise above the thermal shutdown. Power dissipation is highest with higher battery voltages, with higher current limit, and under shorter dc loop conditions. Higher ambient temperature will reduce thermal margin.

Power control may be done in several ways, by use of the integrated automatic battery switch and a lower-voltage auxiliary battery or by use of a power control resistor with single battery operation. The thermal capability of the 44-pin PLCC package is sufficient to allow for single battery operation without the power control resistor when the device is used under lower-power operating conditions.

#### Power Derating

Operating temperature range, maximum current limit, maximum battery voltage, minimum dc loop length, and protection resistors' values, number of PCB board layers, and airflow, will influence the overall thermal performance. The still-air thermal resistance of the 44-pin PLCC package is typically 38 °C/W for a two-layer board with 0 LFPM airflow.

The L9310 will enter thermal shutdown at a temperature of 150 °C. The thermal design should ensure that the SLIC does not reach this temperature under normal operating conditions.

For this example, assume a maximum ambient operating temperature of 85 °C, a maximum current limit of 30 mA, and a maximum battery of -56 V. Further assume a (worst-case) minimum dc loop of 20 Ω for wire resistance, 50 Ω protection resistors, and 200 Ω for the handset. Include the effects of parameter tolerance in these calculations.

$$T_{TSD} - T_{AMBIENT(max)} = \text{allowed thermal rise}$$

$$150\text{ °C} - 85\text{ °C} = 65\text{ °C}$$

$$\text{Allowed thermal rise} =$$

$$\text{package thermal impedance} \times \text{SLIC power dissipation}$$

$$65\text{ °C} = 38\text{ °C/W} \times \text{SLIC power dissipation}$$

$$\text{Allowed SLIC power dissipation (P}_D) = 1.71\text{ W}$$

Thus, in this example, if the total power dissipated on the SLIC is less than 1.71 W, it will not enter thermal shutdown. Total SLIC power is calculated:

$$\text{Total } P_D = \text{maximum battery} \times (\text{maximum current limit})$$

$$(\text{current limit accuracy}) + \text{SLIC quiescent power.}$$

For the L9310, the worst-case SLIC on-hook active quiescent power is 100 mW. Thus,

$$\text{Total off-hook power} = (I_{LOOP})(1.05) \times (V_{BATAPPLIED}) +$$

$$\text{SLIC quiescent power}$$

$$\text{Total off-hook power} = (0.030\text{ A})(1.05) \times (52) + 100\text{ mW}$$

$$\text{Total off-hook power} = 1.864\text{ W}$$

The power dissipated in the SLIC is the total power dissipation less the power that is dissipated in the loop.

$$\text{SLIC } P_D = \text{total power} - \text{loop power}$$

$$\text{Loop off-hook power} = (I_{LOOP} \times 1.05)^2 \times (R_{LOOPdmin} +$$

$$2R_P + R_{HANDSET})$$

$$\text{Loop off-hook power} = \{(0.030\text{ A})(1.05)\}^2 \times$$

$$(20\ \Omega + 100\ \Omega + 200\ \Omega)$$

$$\text{Loop off-hook power} = 317.5\text{ mW}$$

SLIC off-hook power = total off-hook power – loop off-hook power

$$\text{SLIC off-hook power} = 1.864\text{ W} - 0.3175\text{ W}$$

$$\text{SLIC off-hook power} = 1.5465\text{ W} < 1.71\text{ W}$$

Thus, under the operating conditions of this example, the thermal capability of the 44-pin PLCC package is adequate to ensure that the L9310 will not be driven into thermal shutdown and no additional power control measures are needed. If, however, for a given set of operating conditions, the thermal capabilities of the package are not adequate to ensure the SLIC is driven into thermal shutdown, then one of the power control techniques described below should be used. Additionally, even if the thermal capability of the 44-pin PLCC package is adequate to ensure that the L9310 will not be driven into thermal shutdown, the battery switch technique described below can be used to reduce total short-loop power dissipation.



## Applications (continued)

### dc Characteristics (continued)

#### Automatic Battery Switch

Use of the automatic battery switch controls power dissipation by automatically switching to the lower-voltage auxiliary battery under short dc loop conditions, thus reducing the short-loop power that is generated. This has the advantage of not only controlling device temperature rise, but reducing overall power dissipation. The switch will automatically apply the appropriate battery to support the dc loop. No logic control is needed to control the switch. Switching is quiet, and the dc loop current will not be interrupted when switching between batteries. The lower-voltage auxiliary battery is connected to the V<sub>BAT2</sub>/PRW package pin.

The equation governing the switch point is as follows:

$$R_{LOOP} = \frac{|V_{BAT2}| - 3.0}{I_{LIM}} - 2R_P - R_{dc}$$

A graph showing loop and battery current versus loop resistance with use of the battery switch is shown in Figure 12.

The V<sub>BAT2</sub> voltage must be chosen properly so that the power dissipation is minimized. When the voltage at pin PR equals V<sub>BAT2</sub> + 1 V + (50 Ω × I<sub>LOOP</sub>), at least 98% of the loop current minus 2.5 mA flows into V<sub>BAT2</sub> and 2.5 mA + 2% of the loop current plus quiescent current flows into V<sub>BAT1</sub>.

To choose V<sub>BAT2</sub>, add:

1. Maximum tip overhead voltage (2 V for V<sub>OVH</sub> = 0).
2. Maximum loop voltage (maximum loop resistance, protection resistance, and dc feed resistance [100 Ω] times the maximum loop current limit).
3. 1 V for the soft switch.

Thus, for a 40 mA current limit, 640 Ω loop, 30 Ω protection resistors, and 3.17 dBm signal (V<sub>OVH</sub> = 0):

$$V_{BAT2} = -(2 + 0.042 \times (100 + 60 + 640) + 1) = -36.6 \text{ V}$$

Then, for any loop resistance from 0 Ω to 640 Ω, the worst-case V<sub>BAT1</sub> and V<sub>BAT2</sub> currents will be:

$$I_{BAT1} = 1.39 \text{ mA} + 2.5 \text{ mA} + 0.02 \times (42 \text{ mA} - 2.5 \text{ mA}) = 4.68 \text{ mA}$$

$$I_{BAT2} = (0.98) \times 42 \text{ mA} = 38.71 \text{ mA}$$

$$\text{Total max power} = 1.641 \text{ W (} V_{BAT} = -48 \text{ V)}$$

Note that to minimize power statistically, this may not be the best choice for V<sub>BAT2</sub>. Over a large number of lines, power is minimized according to the statistical distribution of loop resistance.

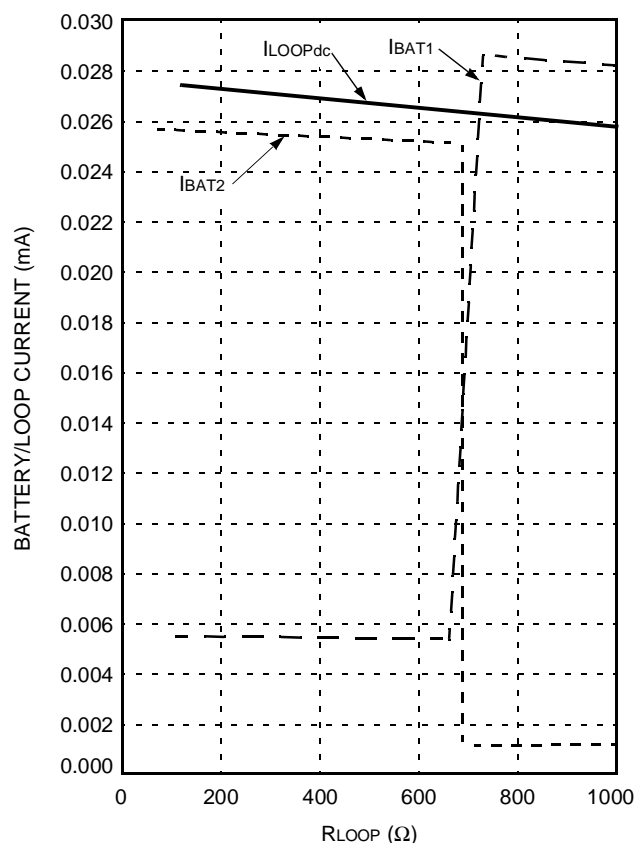

12-3470a (F)

Figure 12. L9310 Loop/Battery Current (with Battery Switch) vs. Loop Resistance

**Applications** (continued)

**dc Characteristics** (continued)

**Power Control Resistor**

Device temperature rise may be controlled with use of a single battery voltage by use of a power control resistor. This technique will reduce power dissipation on the chip, by sharing the total power not dissipated in the loop between the L9310 and the power control resistor. It does not, however, reduce the total power consumed, as does use of the auxiliary battery. The power control resistor is connected from the primary battery to the V<sub>BAT2</sub>/PWR node of the device.

The magnitude of the power control resistor must be low enough to ensure that sufficient power is dissipated on the resistor to ensure the L9310 does not exceed its thermal shutdown temperature. At the same time, the more power that is dissipated by the power control resistor, the higher the resistor's power rating must be, and thus, the more costly the resistor. The following equations are used to optimize the choice (magnitude and power rating) of the power control resistor.

Again assume:

$$T_{TSD} - T_{AMBIENT(max)} = \text{allowed thermal rise}$$

$$150\text{ }^{\circ}\text{C} - 85\text{ }^{\circ}\text{C} = 65\text{ }^{\circ}\text{C}$$

$$\text{Allowed thermal rise} =$$

$$\text{package thermal impedance} \times \text{SLIC power dissipation}$$

$$65\text{ }^{\circ}\text{C} = 38\text{ }^{\circ}\text{C/W} \times \text{SLIC power dissipation}$$

$$\text{Allowed SLIC power dissipation (P}_D) = 1.71\text{ W}$$

This time, assume a maximum ambient operating temperature of 85 °C, a maximum current limit of 45 mA (including tolerance), and a maximum battery of -56 V.

Again, assume a (worst-case) minimum dc loop of 0 Ω and that 50 Ω protection resistors are used. Assume the handset is 200 Ω:

$$\text{Total P}_D = (56\text{ V} \times 45\text{ mA}) + 0.100\text{ W}$$

$$\text{Total P}_D = 2.34\text{ W} + 0.100\text{ W}$$

$$\text{Total P}_D = 2.4375\text{ W}$$

Again, the power dissipated in the SLIC is the total power dissipation less the power that is dissipated in the loop.

$$\text{SLIC P}_D = \text{total power} - \text{loop power}$$

$$\text{Loop power} = (I_{LIM})^2 \times (R_{LOOPdmin} + 2R_P + R_{HANDSET})$$

$$\text{Loop power} = (45\text{ mA})^2 \times (0\text{ } \Omega + 100\text{ } \Omega + 200\text{ } \Omega)$$

$$\text{Loop power} = 0.6075\text{ W}$$

$$\text{SLIC power} = 2.4375\text{ W} - 0.6075\text{ W}$$

$$\text{SLIC power} = 1.83\text{ W} > 1.5\text{ W}$$

Under these extreme conditions, thermal margin is increased via an external power control resistor.

The power dissipated in the power control resistor is calculated by:

$$P_{PRW} = \frac{(|V_{BAT}| - V_{ROH} - V_{LOOP})^2}{R_{PWR}}$$

where in this example:

$$P_{PRW} \text{ is power in the resistor}$$

$$V_{BAT} = -52\text{ V}$$

$$V_{LOOP} = I_{LIM} \times (R_{LOOP} + R_{PROT})$$

$$V_{ROH} \text{ is the ring-side overhead voltage of the SLIC.}$$

Since this device is dc unbalanced, the tip side overhead will remain typically at -2 V and the ring side overhead will vary with the voltage at V<sub>OH</sub>. For the total tip/ring default overhead of 5.5 V, the ring overhead is typically 3.5 V.

**dc Loop Current Limit**

In the active modes, dc current limit is programmable via an applied voltage source at the device's V<sub>PROG</sub> control input. The voltage source may be an external voltage source or derived via a resistor divider network from the V<sub>REF</sub> SLIC output or an external voltage source. A programmable external voltage source may be used to provide software control of the loop current limit. The loop current limit (I<sub>LIM</sub>) is related to the V<sub>PROG</sub> voltage by:

$$I_{LIM} \text{ (mA)} = 50 \times V_{PROG} \text{ (V)}$$

## Applications (continued)

### dc Characteristics (continued)

#### dc Loop Current Limit (continued)

Note that the overall current-limit accuracy achieved will not only be affected by the specified accuracy of the internal SLIC current-limit circuit (accuracy associated with the 50 term), but also by the accuracy of the voltage source and the accuracy of any external resistor divider network used and voltage offsets due to the specified input bias current. If a resistor divider from  $V_{REF}$  is used, a lower magnitude resistor will give a more accurate result due to a lower offset associated with the input bias current; however, lower value resistors will also draw more power from  $V_{REF}$ . The sum of the two resistors in the resistor divider should be between 75 k $\Omega$  and 200 k $\Omega$ . Offset at  $V_{PROG}$  and  $V_{REF}$  accuracies are specified in Table 9 and Table 10.

The above equation describes the active mode steady-state current-limit response. There will be a transient response of the current-limit circuit (with the device in the active mode) upon an on- to off-hook transition. Typical active mode transient current-limit response is given in Table 18.

**Table 18. Typical Active Mode On- to Off-Hook Tip/Ring Current-Limit Transient Response**

Parameter	Value	Unit
dc Loop Current: Active Mode $R_{LOOP} = 100 \Omega$ On- to Off-hook Transition $t < 5$ ms	$I_{LIM} + 60$	mA
dc Loop Current: Active Mode $R_{LOOP} = 100 \Omega$ On- to Off-hook Transition $t < 50$ ms	$I_{LIM} + 20$	mA
dc Loop Current: Active Mode $R_{LOOP} = 100 \Omega$ On- to Off-hook Transition $t < 300$ ms	$I_{LIM}$	mA

The current limit with the SLIC set in an active mode will be different from the current limit with the SLIC set in the scan mode. This is due to differences in the scan clamp circuit versus the active tip/ring drive amplifiers. The scan mode current limit is fixed and is a function of the internal design of the scan clamp circuit. The steady-state scan mode current limit will be a typical 40 mA to 50 mA and may, over temperature and process, vary typically from 30 mA to 110 mA. The scan clamp current limit will typically settle to its steady-state value within 300 ms.

### Overhead Voltage

Overhead is programmable in the active mode via an applied voltage source at the device's OVH control input. The voltage source may be an external voltage source or derived via a resistor divider network from the  $V_{REF}$  SLIC output or an external voltage source. A programmable external voltage source may be used to provide software control of the overhead voltage.

The overhead voltage ( $V_{OH}$ ) is related to the OVH voltage by:

$$V_{OH} = 5.5 \text{ V} + 5 \times V_{OVH} \text{ (V)}$$

Overall accuracy is determined by the accuracy of the voltage source and the accuracy of any external resistor divider network used and voltage offsets due to the specified input bias current. If a resistor divider from  $V_{REF}$  is used, lower magnitude resistor will give a more accurate result due to a lower offset associated with the input bias current; however, lower value resistors will also draw more power from  $V_{REF}$ . The sum of programming resistors should be between 75 k $\Omega$  and 200 k $\Omega$ .

Note that a default overhead voltage of 5.5 V is achieved by shorting input pin OVH to analog ground. Internally, the SLIC needs typically 2 V from each supply rail to bias the amplifier circuitry. This can be thought of as an internal saturation voltage.

The default overhead provides sufficient headroom for on-hook transmission of a 3.14 dBm signal into 900  $\Omega$ .

$$3.14 = 10 \log \frac{V^2}{0.9}$$

$V = 1.36$  V, which is required over and above the internal saturation voltage for signal swing.

$1.36 \text{ V} + 4 \text{ V} = 5.36 \text{ V} < 5.5 \text{ V}$  default overhead; thus, a 3.14 dBm into 900  $\Omega$  signal is passed without clipping distortion.

The overhead voltage accuracy achieved will not only be affected by the accuracy of the internal SLIC circuitry, but also by the accuracy of the voltage source and the accuracy of any external resistor divider network used.

In the scan mode, overhead is unaffected by  $V_{OVH}$  and internally fixed by the scan clamp circuitry to within the specified limits.

**Applications** (continued)

**dc Characteristics** (continued)

**Overhead Voltage** (continued)

The TESTSIG and RCV inputs will not overload with an input signal swing between ground and  $V_{CC} - 0.5$  V. However, the SLIC output saturation point (at PT/PR) is a function of the device overhead. Default overhead with  $OVH = 0$  is 3.14 dBm into 900  $\Omega$ . After that, output signal swing increases 1 V for every volt that overhead is increased.

Overhead voltage may need to be increased to accommodate on-hook transmission of higher-voltage signals, such as meter pulse. The following example is meant to illustrate the design procedure that can be followed.

Assume that an on-hook transmission of a 2.2 Vrms meter pulse into 200  $\Omega$  is needed. Further assume 50  $\Omega$  protection resistors are used.

$$V_{OH} = 4.0 \text{ V} + (1 + (2 \times R_p)/200) \times V_{peak}$$

$$V_{OH} = 4.0 + (1 + (2 \times 50)/200) \times 2.2 \text{ (1.414)}$$

$$V_{OH} = 8.662 \text{ V}$$

Adding 0.5 V for tolerance, the overhead needs to be increased to  $(8.662 + 0.5) 9.16 \approx 9.2$  V to allow for an undistorted on-hook transmission of a 2.2 Vrms meter pulse into 200  $\Omega$ .

The overhead is set with respect to battery voltage and during a test mode, the battery voltage is unknown. With zero voltage on RCV input, the output is battery voltage minus the overhead on the input, which is the main offset. The small RCV input offset that is multiplied by RCV gain to tip/ring output is inconsequential.

**Loop Range**

The dc loop range is calculated using:

$$R_L = \frac{|V_{BAT}| - V_{OH}}{I_{LOOP}} - 2R_P - R_{dc}$$

$V_{BAT1}$  is used because the maximum loop range is being calculated. The loop resistance value where the device automatically switches to  $V_{BAT2}$  is calculated in the Automatic Battery Switch section of this data sheet.

**Battery Feed**

The L9310 operates in a dc unbalanced mode. In the forward active state, under open circuit (on-hook) conditions, with the default overhead chosen, the tip to ring voltage will be a nominal 5.5 V less than the battery. This is the overhead voltage. The tip and ring overhead is achieved by biasing ring a nominal 3.5 V above battery and by biasing tip a nominal 2.0 V below ground.

During off-hook conditions, some dc resistance will be applied to the subscriber loop as a function of the physical loop length, protection, and telephone handset. As the dc resistance decreases from infinity (on-hook) to some finite value (off-hook), the tip to ring voltage will decrease as shown in Figure 13.

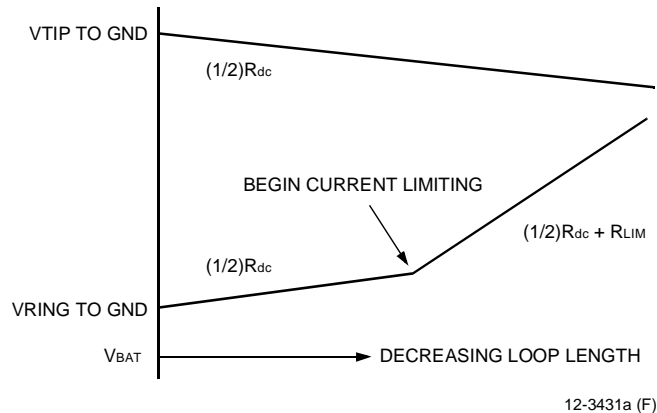

**Figure 13. Tip/Ring Voltage**

As illustrated in Figure 13, as loop length decreases, the tip to ground voltage will decrease with a slope corresponding to one-half the internal dc feed resistance of the SLIC (typical 75  $\Omega$ ). The ring to ground voltage will also decrease with a slope corresponding to one-half the internal dc feed resistance of the SLIC, until the SLIC reaches the current-limit region of operation. At that point, the slope of the ring to ground voltage will increase to the sum of one half the internal dc feed resistance plus approximately 10 k $\Omega$ .

The dc feed characteristic can be described by:

$$I_{LOOP} = \frac{|V_{BAT}| - V_{OH}}{R_{LOOP} + 2R_P + R_{dc}}$$

$$V_{T/R} = \frac{(|V_{BAT}| - V_{OH}) \cdot R_{LOOP}}{R_{LOOP} + 2R_P + R_{dc}}$$

Where:

- $I_{LOOP}$  = dc loop current.
- $V_{T/R}$  = dc loop voltage.
- $|V_{BAT}|$  = battery voltage magnitude.
- $V_{OH}$  = overhead voltage.
- $R_{LOOP}$  = loop resistance, including wire and handset resistance.
- $R_P$  = protection resistance.
- $R_{dc}$  = SLIC internal dc feed resistance.

Refer to Figure 13 and Figure 14 in this section and to Figure 12 in the Automatic Battery Switch section.

**Applications** (continued)

**dc Characteristics** (continued)

**Battery Feed** (continued)

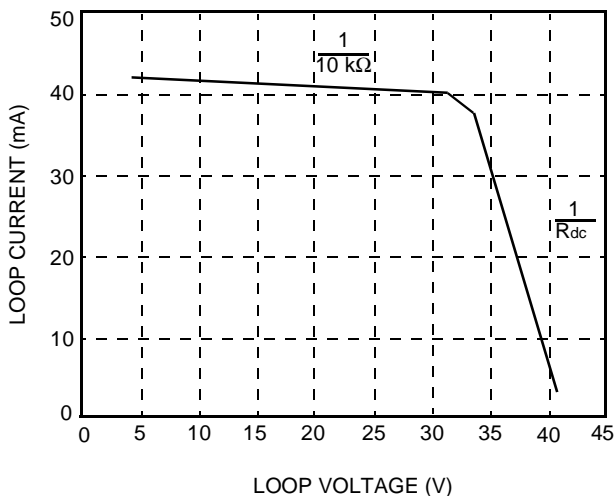

Notes:  
 VBAT1 = -48 V.  
 VBAT2 = -24 V.  
 ILIM = 40 mA (RPROG = 66.5 kΩ).

12-3050.g (F)

**Figure 14. L9310 Loop Current vs. Loop Voltage**

Starting from the on-hook condition and going through to a short circuit, the curve passes through two regions:

Region 1: On-hook and low loop currents: the slope corresponds to the dc feed resistance of the SLIC (plus any series resistance). The open-circuit voltage is the battery voltage less the overhead voltage of the device.

Region 2: Current limit: the dc current is limited to a value determined by VPROG. This region of the dc template has a high resistance (10 kΩ).

Notice that the I-V curve is uninterrupted when the power is shifted from the high-voltage battery to the low-voltage battery (if auxiliary battery option is used).

This is shown in Figure 12 in the Automatic Battery Switch section.

**Battery Reversal Rate**

The rate of battery reverse is controlled or ramped by capacitors FB1 and FB2. A chart showing FB1 and FB2 values versus typical ramp time is given below. Leave FB1 and FB2 open if it is not desired to ramp the rate of battery reversal.

**Table 19. FB1 and FB2 Values vs. Typical Ramp Time**

CFB1 and CFB2*	Transition Time
0.01 μF	20 ms
0.1 μF	220 ms
0.22 μF	440 ms
0.47 μF	900 ms
1.0 μF	1.8 s
1.22 μF	2.25 s
1.3 μF	2.5 s
1.4 μF	2.7 s
1.6 μF	3.2 s

\* Typical recommended value for CFB1 and CFB2 is less than 0.033 μF.

**Longitudinal to Metallic Balance**

Longitudinal to metallic balance at PT/PR is specified in the Electrical Characteristics section of this data sheet.

**Supervision**

**Loop Closure**

Loop closure supervision threshold is programmed via an applied voltage source or ground, through a resistor at the LCTH input. Loop closure status is presented at the NSTAT output. NSTAT is an unlatched output that represents either the loop closure or ring trip status, depending on the device state. See Table 2 and Table 3 for more details. Loop closure threshold current (ILCTH) is set by:

$$\frac{250(V_{REF} - V_{LCTH})}{R_{LCTH} (k\Omega)} = I_{LCTH} (mA)$$

where:

RLCTH is a resistor from the LCTH node to ground or a voltage source.

VLCTH is ground or an external voltage source.

There is a built-in hysteresis associated with the loop closure detector. The above equation describes the on-hook to off-hook threshold. To help prevent false glitches, the off-hook to on-hook threshold will be a typical 20% lower than the corresponding on-hook to off-hook threshold. PPM injection can cause false loop closure indication. Connect a 0.01 μF capacitor to a 0.1 μF capacitor from this node, LCF to Vcc to filter the loop closure detector the larger the capacitor the higher the filtering. If loop closure filtering is not required, leave LCF open.

## Supervision (continued)

### Ring Trip

Ring trip is set by the value of RS1.

The ring trip threshold at the ring trip inputs is  $\pm 2.5$  V minimum,  $\pm 3.5$  V maximum.

A resistor value of 400  $\Omega$ , as shown in Figure 4, will set the ring trip current threshold to  $\pm 7.5$  mA typical.

Ring trip is asserted upon entering the ringing mode until the second zero crossing of ringing. This is either a positive-going zero crossing (between  $-40$  V and  $-30$  V at  $-50$  V  $V_{BAT}$ ) or a negative-going zero crossing (between  $-10$  V and  $-20$  V at  $-50$  V  $V_{BAT}$ ). The different threshold for positive-going and negative-going zero crossings is the result of hysteresis of approximately 20 V. The act of turning on the switch may or may not produce a ringing zero crossing, therefore, there may be a delay of up to almost one cycle of ringing or 50 ms until NSTAT is high.

Ring trip will not be asserted unless the ring trip threshold is exceeded for two zero crossings. This is either a positive-going zero crossing (between  $-40$  V and  $-30$  V at  $-50$  V  $V_{BAT}$ ) or a negative-going zero crossing (between  $-10$  V and  $-20$  V at  $-50$  V  $V_{BAT}$ ). The different threshold for positive-going and negative-going zero crossings is the result of hysteresis of approximately 20 V.

Note that since the ringing voltage is monitored at RSW, one zero crossing can occur at switch turn-on depending on initial conditions.

Ring trip is asserted immediately if the ring trip input is  $15$  V  $\pm 3$  V.

### Tip or Ring Ground Detector

In the ground key or ground start applications, a common-mode current detector is used to indicate that either a tip or ring ground has occurred (ground key) or an off-hook has occurred (ground start). The detection threshold is set by connecting a resistor from ICM to ground.

$$2350/R_{ICM} \text{ (k}\Omega\text{)} = I_{TH} \text{ (mA)}$$

Additionally, a filter capacitor across  $R_{ICM}$  will set the time constant of the detector. No hysteresis is associated with this detector.

## Switching Behavior

The solid-state ring relay in the L9310 device is able to provide either make-before-break or break-before-make timing with respect to switching into and out of the ring mode. If switching is done directly into and out of the ring mode, the design of the L9310 will give make-before-break switching with respect to both the ring and tip side switches. To achieve break-before-make switching, the user should, via software control, enter an intermediate all-off mode when switching into and out of the ring mode. The all-off state should be held a minimum of 8 ms.

### Make-Before-Break Operation

The break switches are constructed from DMOS transistors. The tip side ring return is also a DMOS transistor. Because the on resistance of the break switches is less than the tip side ring return switch, the break switches are physically bigger. This implies a larger gate to source capacitance, with inherently slower switching speeds since it will take longer to charge or discharge the gate to source capacitance of the break switches (to change the state of the switch). The ring access switch is a pnpn type device. The pnpn device has inherently faster switching speeds than any of the DMOS type switches.

Going from the active to ring mode, the smaller tip side ring return switch and the pnpn ring access switch will change states before the larger break switches. Thus, the ring contacts are made before the line break switches are broken: make-before-break operation.

Going from the ring mode to active or scan, the natural tendency is for the smaller tip side ring return DMOS to break or open, before the larger DMOS can turn on. This would not be make-before-break operation on the tip side. Thus, circuitry is added to speed up charging of the tip break switch, to speed up the turn on of that switch to give make-before-break operation on the tip side.

On the ring side, going from the ring mode to the active or scan mode, the pnpn will not turn off until the ring current drops below the hold current of the pnpn device (which is typically 500  $\mu$ A); this is effectively zero current for zero current turn off. This can take up to one-half cycle of ringing to occur. With this inherent delay in switching by the pnpn ring access switch, the break switches will make contact before the ring access switch breaks contact; so again, make-before-break switching is achieved.

## Supervision (continued)

### Make-Before-Break Operation (continued)

With the make-before-break switch, there will be a period of time (depending on ring signal frequency but measured in tens of microseconds) where all four switch contacts will be on. This means that the ring generator will be connected through the current-limited break switches to the input of the SLIC device. Current will be limited by the break switch current limit, and this will not damage the SLIC. This current may, however, cause a false glitch at the NSTAT supervision output that will need to be digitally filtered. The board designer should consider any ramifications of this state on the overall system or ring generator and battery design.

The major benefit of make-before-break switching is that it will minimize any impulse noise generated during ringing cadence. In many cases when operating the switch in the make-before-break mode, no special design to switch at zero current and voltage crossing is required. Impulse noise generation when using solid-state relays is documented in the *Impulse Noise and the L758X Series of Solid State Switches* Application Note.

### Break-Before-Make Operation

To achieve break-before-make, use the logic control sequence device switching as shown below.

**Table 20. Break-Before-Make Logic Control Sequence Device Switching**

State	Break Switches	Ring Switches	Comment
Active/Scan	closed	open	—
Disconnect (all-off)	open	open	hold >8 ms
Ring	open	closed	—
Disconnect (all-off)	open	open	hold >8 ms
Active/Scan	closed	open	—

The advantage of break-before-make operation is that it eliminates the current spike when the ring access relay changes state. The disadvantage is that it forces an all-off state. Under inductive ringing loads, due to  $Ldi/dt$  effects, may cause a reduction in the impulse noise performance compared to make-before-break switching.

## Protection

### External Protection

An external overvoltage clamp is required to ensure that the off-state and on-state ratings of the solid-state break switch and solid-state ring access switch are not exceeded. The solid-state switches in the L9310 are constructed in a dielectrically isolated high-voltage technology. Because of the high device-to-device isolation that is inherent in the dielectric isolation, only a tip to ground and a ring to ground clamp is required. A tip to ring overvoltage clamp is not needed. A foldback or crowbar type device is recommended to minimize power across the solid-state switches under a fault condition.

The break switches and tip return switch are constructed from DMOS transistors. Because the on resistance of the break switches is less than the tip side ring return switch, the break switches are physically bigger and have a higher current handling capability. Additionally, the break switches have a foldback characteristic which enables them to survive a higher on-state voltage (320 V) than the tip ring return switch (130 V), which does not have the foldback characteristic. (See the On-State Switch I-V Characteristics section.) The ring access switch is a pnpn type device. Additionally, the ring side will see the full power ring voltage, and the tip side switch will see the power ringing voltage that is attenuated by the ringing load, subscriber loop, feed resistor, and protection resistors. Because of these differences, the protection requirements on the tip side are different from the protection requirements on the ring side. Thus, it is recommended that an asymmetrical (with respect to tip and ring) overvoltage protection scheme be used.

Please contact your Agere Account Representative for a recommended protection device.

Additionally, a series protection resistor with a fusible characteristic or a PTC resistor is recommended to limit current during lightning and power cross faults. A minimum 50  $\Omega$  is recommended in tip and ring.

## **Protection** (continued)

### **External Protection** (continued)

The overall device protection is achieved through a combination of the external overvoltage and overcurrent devices, along with the integrated thermal shutdown feature, the integrated window comparator, the break switch foldback characteristic, and the dc/dynamic current-limit response of the break and tip return switches.

### **Active Mode Response at PT/PR**

The line break switches and tip return switch are current-limited switches. The current-limit mechanism limits current through the switch to the specified dc current limit under low frequency or dc faults (power cross and/or tip-ring to ground short) and limits the current to the specified dynamic current-limit response under transient faults, such as lightning.

During a lightning fault (typical 1000 V 10 x 700  $\mu$ s applied surge), the current-limited line break switches will pass typically 2.5 A for 0.5  $\mu$ s before forcing the break switches off. Once in the off state, the external protection device must ensure that the off-state voltage rating of 320 V is not exceeded. Note that the maximum differential voltage is the positive zener rating of the protection device less the battery voltage, which will appear on the line feed side of the switch.

For a lower-voltage power cross, whose maximum peak voltage is below the foldback voltage breakpoint 1 (V1), the current-limited break switch will pass the current equal to the dc current limit. The current limit has a negative temperature coefficient, so as the device continues to pass current, the current limit will reduce with increasing device temperature. Ultimately, the device will reach the thermal shutdown temperature and the thermal shutdown mechanism will force an all-off state, which will stop current flow and begin device cooling. In the all-off state, the external protection device ensures that the switch off-state voltage rating is not exceeded. Once the device cools significantly, the break switches will turn on, and current will begin to flow again, until temperature forces the all-off state. This will continue until the fault condition is gone.

Sneak-under surge is a voltage surge that is just below the clamping threshold of the secondary protection device. For this type of surge, when the surge voltage

is below the foldback voltage breakpoint 1, operation is as described above. When the surge voltage rises above the foldback voltage breakpoint 1 (V1), but is still less than the secondary protector clamping voltage, the line break switch will crowbar into the high-impedance region of its I-V characteristic and reduce current to the specified I<sub>LIMIT2</sub> value.

For surges whose magnitude range above the trigger of the external secondary protector, the device will operate as described above for the portion of the surge below the secondary protector trigger voltage. When the voltage rises above the external secondary protector's trigger voltage, the secondary protector will crowbar on, shunting fault current to ground and reducing the tip/ring voltage seen at the device.

In the active mode, the external secondary protector must ensure that the off-state voltage ratings of the ring access and ring return switch are not exceeded. Normally, the ring return switch is connected to ground on the TRING side and to the protector on the PT side; thus, the protector on the tip side in the active mode must clamp at less than 320 V. As will be seen in the Ring Mode Response at PT/PR section, during the power ringing mode, this clamp voltage on the tip side is significantly less than 320 V.

Normally, the ring access switch is connected to the ring generator on the RRING side and to the protector on the PR side; thus, on one side of the switch, there is the battery voltage and the peak negative ring signal, and on the PR side, the maximum turn-on voltage of the secondary protector. The ring access switch is of pnpn construction. Thus, if the off-state voltage rating of the ring access switch is exceeded, the device will crowbar into a low-impedance state. This will cause a surge into the ring generator and can cause the on-state current rating of the switch to be exceeded.

The difference of the battery plus peak negative ring signal voltage less the maximum turn on of the secondary protector must not exceed the off-state voltage rating of the ring access switch. Additionally, as the secondary protector will see the power ring signal, the minimum turn-on rating of the secondary protector must be high enough to not clamp the ring signal and cause clipping distortion. The ring side will see the full power ring voltage, and the tip side switch will see the power ringing voltage that is attenuated by the ringing load, subscriber loop, feed resistor, and protection resistors; thus, the ring side secondary protector requires a higher clamping voltage than the tip side.



## Protection (continued)

### Ring Mode Response at PT/PR

In this mode, the line break switches are off and the ring access and ring return switch is on. The secondary protectors must ensure that the minimum off-state voltage rating of the line break switches is not exceeded. Note that the maximum differential voltage is the positive zener rating of the protection device less the battery voltage which will appear on the line feed side of the switch.

The ring access switch is a pnpn type switch. This switch has no internal current limiting. Thus, through external current limit, the user must ensure that the surge ratings (both dynamic and dc for lightning and power cross faults) are not exceeded. A minimum 400  $\Omega$  ring feed resistor is recommended. This resistor also will set the ring trip threshold. See the Ring Trip section within the Supervision section of this data sheet.

During a lightning fault (typical 1000 V 10 x 700  $\mu$ s applied surge), the current-limited tip return switch will pass, typically 2.5 A for 0.5  $\mu$ s before forcing the switch off. Once in the off state, the external protection device must ensure that the off-state voltage rating of 320 V is not exceeded.

For power cross for lower-voltage faults, the tip side power ringing return switch will behave like the line break switches. However, this switch does not have the foldback clamping feature that is included in the line break switches; thus, in the on state, the voltage seen by the tip side power ringing return switch before damage is less than the line break switches. The on-state voltage of the line break switches can go up to the off-state voltage rating. The tip side power ringing return voltage should see less than 130 V in the on state. Thus, the secondary protector on the tip side should have a maximum crowbar voltage of 130 V. With typical protection device tolerance, this implies a minimum clamping voltage of 100 V. The users should ensure, based on minimum loop length, ringing load, and peak ring signal voltage, that the ring signal is not distorted by the (lower) voltage rating of the tip-side protector.

### Internal Tertiary Protection

The external secondary protector and switch current limit protect the 320 V high-voltage switches from lightning and power cross conditions. Integrated into the LILAC IC is an internal tertiary protection scheme that is meant to protect the 90 V SLIC portion of the device from residue fault current and voltages that may be

passed through the switches to the actual SLIC inputs. This scheme includes an internal diode bridge voltage clamp and a battery out of range detector that forces an all-off condition if the battery voltage falls high or low out of the specified operating range.

### Diode Bridge

The internal inputs of the actual SLIC chip are clamped to ground and to  $V_{BAT1}$  by an integrated diode bridge. Residual positive fault currents are clamped to ground and residual negative fault currents are clamped to battery. This implies that the battery have some current-sinking capability.

High common-mode currents, as may be seen under a fault condition, will be sensed and reduced to zero by the battery monitor circuit (see Battery Out of Range Detector: High [Magnitude] section). However, this detector will not prevent longitudinal current from flowing into battery. The battery supply must have the ability to sink longitudinal currents as specified in the longitudinal current capability requirement in Table 10.

### Battery Out of Range Detector: High (Magnitude)

This feature is useful in remote power applications where a dc-dc converter with limited ability to sink current is used as the primary battery supply. Under a fault condition, the diode bridge will want to sink current into the battery. As a function of the dc-dc converter input capacitance and design, this current may cause the magnitude of supply voltage to rise and ultimately cause damage to the supply. To prevent damage to the supply, the LILAC device will monitor the battery supply voltage. If the magnitude of the battery rises above the maximum specified operating battery, the battery out of range detector will force the line break switches and ring access switches into an all-off state, and will also force the SLIC into the disconnect state. This will stop the current flow into the battery, preventing damage to the battery fault conditions. NSTAT is forced low during this mode of operation.

### Battery Out of Range Detector: Low (Magnitude)

The LILAC device will monitor the battery supply voltage. If the magnitude of the battery drops below the minimum specified operating battery, the battery out of range detector will force the line break switches and ring access switches into an all-off state, and will also force the SLIC into the disconnect state. NSTAT is forced low during this mode of operation.

## Special Functions

### Periodic Pulse Metering (PPM)

Periodic pulse metering (PPM), also referred to as TTX, is input to the PPMIN input of the L9310. Upon application of appropriate logic control, this signal is presented to the tip/ring subscriber loop. The state of the L9310 may be changed while applying PPM signals. The L9310 assumes that a shaped PPM signal is applied to the PPMIN input.

Sufficient drive current is available in the tip and ring drive amplifiers to support 2.5 Vrms PPM signals into a 200 Ω load with a 70 mA dc current limit, and a 5 Vrms PPM signal into a 200 Ω load with a 45 mA dc current limit.

PPM input signals may be a maximum 1.25 V at PPMIN. The gain from PPMIN to tip/ring is 10. Thus, for 2.5 Vrms at tip and ring, apply a 0.25 Vrms signal at PPMIN. The PPM signal should be ac coupled to PPMIN through a 0.01 μF capacitor.

When applied to tip and ring, the PPM signal will also be returned through the SLIC and will appear at the SLIC VITR output. The concern is that this high-voltage signal can overload the codec input and cause distortion of the (desired) ac signal. Therefore, some sort of PPM rejection scheme must be employed. Refer to Figure 1, Architecture Diagram. The L9310 outputs pin PPMOUT, which is the output of the PPM input amplifier. Connecting a resistor, R<sub>PPM</sub>, from PPMOUT to node ITR will provide a path for a hybrid reject of the returned meter pulse signal. The return path from tip and ring to VITR for the PPM signal is through the internal AX amplifier. ITR is the input to this amplifier. Through R<sub>PPM</sub>, by applying a PPM signal equal in magnitude, but 180 degrees out of phase to the returned PPM signal at ITR, the PPM signal is cancelled, preventing overload at the codec input. Even if the cancellation is not perfect, the idea is to reduce the PPM signal so as not to overload the codec. Codecs typically have a low-pass filter at their input to reject any residual meter pulse signal.

The value of R<sub>PPM</sub> is selected by:

$$R_{PPM} = \left[ \frac{(V_{PPMIN} \times 10)}{(R_{PPMLOAD} + R_{dc} + 2R_P)} / 324.5 \right]^{-1}$$

In the case of very high meter pulse signals, such as 5 Vrms, the cancellation provided by resistor R<sub>PPM</sub> may not be sufficient to prevent overload at the codec input. In this case, additional filtering/rejection may be necessary.

PPM injection can cause false loop closure indication. Connect a 0.01 μF capacitor from this node LCF to V<sub>cc</sub> to filter the loop closure detector. If loop closure filtering is not required, leave LCF open.

### Line Test

The L9310 provides line test capability. Through a series of integrated analog switches, in the test mode, an analog voltage proportional to the dc tip to ground voltage, dc ring to ground voltage, the differential dc tip to ring voltage may be generated at the SLIC TESTLEV output. Additionally, an analog voltage proportional to the dc tip to ground current, dc ring to ground current, the differential dc tip to ring current may also be generated at the SLIC TESTLEV.

Figure 2 shows the architecture of the integrated test switches. The test switches are configured via the logic input table to provide voltage measurements, tip to ground, ring to ground, and tip to ring. A voltage that is proportional to the ac tip/ring current appears at the VITR output; thus, for ac current measurements, the test switches apply the VITR output to the TESTLEV output. A voltage that is proportional to the ac plus dc tip/ring current appears at the VTX output; thus, for dc current measurements, the test switches apply the VTX output to the TESTLEV output, with TESTSIG input grounded.

Differential tip to ring current is achieved via the logic truth table. Additionally, individual control of the line break switches allows tip to ground current measurements (tip break switch closed, ring break switch open, tip amp state) or ring to ground current measurements (tip break switch open, ring break switch closed, ring amp state).

An analog ac test tone may also be applied to a test input TESTSIG. TESTSIG input is active upon entering a test state and remains active until leaving the test mode. Using this feature, a voltage proportional to ac tip to ground voltage, ac ring to ground voltage, the differential ac tip to ring, the ac tip to ground current, ac ring to ground current, the differential ac tip to ring current may also be generated at the SLIC TESTLEV. By varying the frequency of the applied test tone, parameters such as line capacitance may be measured.

If the codec can accommodate self-test features, the L9310 can be configured to operate in this mode. During the test modes, the L9310 receive path is active; thus, a test tone may be applied at the RCVN/RCVP inputs, through the codec, via a PCM input. In this mode of operation, couple TESTLEV, not VITR, to the codec.

**Special Functions** (continued)

**Line Test** (continued)

All measurements that appear at the TESTLEV output are referenced to the internal VREF voltage of the device. For that reason, there is a test mode in which VREF itself will appear at the TESTLEV output.

When making a voltage measurement, first measure VREF and subtract VREF from VTESTLEV.

When making a current measurement, open the line break switches and measure VTESTLEV. This value is

then subtracted from the VTESTLEV that is seen during the actual measurement. Note that due to internal biasing of the line break switches, the value seen at VTESTLEV with the line break switches open will be less than the value seen with the line break switches closed under on-hook (open-loop) conditions.

TESTSIG should be externally connected to the device's VREF if it is not used during a test condition. This may be done by a high-impedance pull-up resistor. Additionally, TESTSIG should be ac coupled to the test signal generator.

Table 21 shows design equations to measure the various line voltages and currents.

**Table 21. TESTLEV Output Options**

Test Mode	Relationship	Comments
Test Off	High Impedance	—
VREF	$V_{TESTLEV} = V_{REF} + V_{OFFSET}$	Unity follower on VREF. This is the voltage measurement calibration state, use the VREF state in the secondary control state table.
Tip-to-Ring Voltage	$(V_{TIP} - V_{RING}) = 75 (1 - 0.0075  V_{TL} ) \times V_{TL}$ $V_{TL} = V_{TESTLEV} - (V_{REF} + V_{OFFSET})$	Difference amp.
Tip-to-Ground Voltage	$V_{TIP} = -75 (1 - 0.0075  V_{TL} ) \times V_{TL} + V_{REF} + V_{OFFSET}$ $V_{TL} = V_{TESTLEV} - (V_{REF} + V_{OFFSET})$	Inverting amp.
Ring-to-Ground Voltage	$V_{RING} = -75 (1 - 0.0075  V_{TL} ) \times V_{TL} + V_{REF} + V_{OFFSET}$ $V_{TL} = V_{TESTLEV} - (V_{REF} + V_{OFFSET})$	Inverting amp.
VTX, Zero Current (tip open, ring open)	$V_{TESTLEV} = V_{ZEROCUR}$	Unity follower on VTX close to VREF + VAXOFFSET + VOFFSET. This is the current measurement calibration state. In the secondary control state table, use tip amp or ring amp for single-ended current measurement calibration. Use tip and ring amp for differential current measurement calibration. Do not use the disconnect mode for current calibration.
VTX, dc Current Tip/Ring (tip closed, ring closed)	$V_{TESTLEV} = 20 \text{ V/A} \times I_{TIP\text{-to-RING}} + V_{ZEROCUR}$	Differential current.
VTX, dc Current Ring Ground (tip closed, ring open)	$V_{TESTLEV} = 10 \text{ V/A} \times I_{TIP\text{-to-RING}} + V_{ZEROCUR}$	Single-ended voltage.
VTX, dc Current Ring Ground (tip open, ring closed)	$V_{TESTLEV} = -10 \text{ V/A} \times I_{TIP\text{-to-RING}} + V_{ZEROCUR}$	Single-ended voltage.
VITR, Zero Current (tip open, ring open)	$V_{TESTLEV} = V_{ZAC}$	Unbuffered output of VITR close to VREF + VAXOFFSET + VACOFFSET. This is the current measurement calibration state. In the secondary control state table, use tip amp or ring amp; for single-ended current measurement calibration, use tip and ring amp for differential current measurement calibration. Do not use the disconnect mode for current calibration.
VITR, ac Current (tip closed, ring closed)	$V_{TESTLEV} = 300 \text{ V/A} \times I_{TIP\text{-to-RING}} + V_{ZAC}$	—

## ac Applications

### ac Parameters

There are four key ac design parameters. **Termination impedance** is the impedance looking into the 2-wire port of the line card. It is set to match the impedance of the telephone loop in order to minimize echo return to the telephone set. **Transmit gain** is measured from the 2-wire port to the PCM highway, while **receive gain** is done from the PCM highway to the transmit port. Transmit and receive gains may be specified in terms of an actual gain, or in terms of a transmission level point (TLP), that is, the actual ac transmission level in dBm. Finally, the **hybrid balance** network cancels the unwanted amount of the receive signal that appears at the transmit port.

### Codec Types

At this point in the design, the codec needs to be selected. The interface network between the SLIC and codec can then be designed. Below is a brief codec feature summary.

**First-Generation Codecs.** These perform the basic filtering, A/D (transmit), D/A (receive), and  $\mu$ -law/A-law companding. They all have an op amp in front of the A/D converter for transmit gain setting and hybrid balance (cancellation at the summing node). Depending on the type, some have differential analog input stages, differential analog output stages, +5 V only or  $\pm 5$  V operation, and  $\mu$ -law/A-law selectability. These are available in single and quad designs. This type of codec requires continuous time analog filtering via external resistor/capacitor networks to set the ac design parameters. An example of this type of codec is the Agere T7504 quad 5 V only codec.

This type of codec tends to be the most economical in terms of piece part price, but tends to require more external components than a third-generation codec. Further ac parameters are fixed by the external R/C network so software control of ac parameters is difficult.

**Third-Generation Codecs.** This class of devices includes all ac parameters set digitally under microprocessor control. Depending on the device, it may or may not have data control latches. Additional functionality sometimes offered includes tone plant generation and reception, PPM generation, test algorithms, and echo

cancellation. Again, this type of codec may be +5 V only or  $\pm 5$  V operation, single quad or 16-channel, and  $\mu$ -law/A-law or 16-bit linear coding selectable. Examples of this type of codec are the Agere T8536/7 (5 V only, quad, standard features), T8533/4 (5 V only, quad with echo cancellation), and T8531/36 (5 V only, 16-channel with self-test).

### ac Interface Network

The ac interface network between the L9310 and the codec will vary depending on the codec selected. With a first-generation codec, the interface between the L9310 and codec actually sets the ac parameters. With a third-generation codec, all ac parameters are set digitally, internal to the codec; thus, the interface between the L9310 and this type of codec is designed to avoid overload at the codec input in the transmit direction, and to optimize signal to noise ratio (S/N) in the receive direction.

Because the design requirements are very different with a first- or third-generation codec, the L9310 is offered with two different receive gains. Each receive gain was chosen to optimize, in terms of external components required, the ac interface between the L9310 and codec.

With a first-generation codec, the termination impedance is set by providing gain shaping through a feedback network from the SLIC VITR output to the SLIC RCVN/RCVP inputs. The L9310 provides a transconductance from T/R to VITR in the transmit direction and a single-ended to differential gain in the receive direction from either RCVN or RCVP to T/R. Assuming a short from VITR to RCVN or RCVP, the maximum impedance that is seen looking into the SLIC is the product of the SLIC transconductance times the SLIC receive gain, plus the protection resistors. The various specified termination impedance can range over the voiceband as low as 300  $\Omega$  up to over 1000  $\Omega$ . Thus, if the SLIC gains are too low, it will be impossible to synthesize the higher termination impedances. Further, the termination that is achieved will be far less than what is calculated by assuming a short for SLIC output to SLIC input. In the receive direction, in order to control echo, the gain is typically a loss, which requires a loss network at the SLIC RCVN/RCVP inputs, which will reduce the amount of gain that is available for termination impedance. For this reason, a high-gain SLIC is required with a first-generation codec.

## ac Applications (continued)

### ac Interface Network (continued)

With a third-generation codec, the line card designer has different concerns. To design the ac interface, the designer must first decide upon all termination impedance, hybrid balances, and TLP requirements that the line card must meet. In the transmit direction, the only concern is that the SLIC does not provide a signal that is too large and overloads the codec input. Thus, for the highest TLP that is being designed to, given the SLIC gain, the designer, as a function of voice band frequency, must ensure the codec is not overloaded. With a given TLP and a given SLIC gain, if the signal will cause a codec overload, the designer must insert some sort of loss, typically a resistor divider, between the SLIC output and codec input.

In the receive direction, the issue is to optimize the S/N. Again, the designer must consider all the considered TLPs. The idea, for all desired TLPs, is to run the codec at or as close as possible to its maximum output signal, to optimize the S/N. Remember, noise floor is constant, so the larger the signal from the codec, the better the S/N. The problem is if the codec is feeding a high-gain SLIC, either an external resistor divider is needed to knock the gain down to meet the TLP requirements, or the codec is not operated near maximum signal levels, thus compromising the S/N.

Thus, it appears the solution is to have a SLIC with a low gain, especially in the receive direction. This will allow the codec to operate near its maximum output signal (to optimize S/N), without an external resistor divider (to minimize cost).

Note also that some third-generation codecs require the designer to provide an inherent resistive termination via external networks. The codec will then provide gain shaping, as a function of frequency, to meet the return loss requirements. Further stability issues may add external components or excessive ground plane requirements to the design.

To meet the unique requirements of both types of codecs, the L9310 offers two receive gain choices. These receive gains are mask programmable at the factory and are offered as two different code variations. For interface with a first-generation codec, the L9310 is offered with a receive gain of 8. For interface with a third-generation codec, the L9310 is offered with a receive gain of 2. In either case, the transconductance in the transmit direction, or the transmit gain, is  $300\ \Omega$ .

This selection of receive gain gives the designer the flexibility to maximize performance and minimize external components, regardless of the type of codec chosen.

## Design Tools

The following examples illustrate the design techniques/equations followed to design the ac interface with a first- or third-generation codec for both a resistive and complex design. To aid the line circuit design, Agere has available *Windows*\*-based spreadsheets to do the individual component calculations. Further, Agere has available *PSPICE*<sup>†</sup> models for circuit simulation and verification. Consult your Agere Account Representative to obtain these design tools.

### First-Generation Codec ac Interface Network

Termination impedance may be specified as purely resistive or complex, that is, some combination of resistors and capacitors that causes the impedance to vary with frequency. The design for a pure resistive termination, such as  $600\ \Omega$ , does not vary with frequency, so it is somewhat more straightforward than a complex termination design. For this reason, the case of a resistive design and complex design will be shown separately.

\* *Windows* is a registered trademark of Microsoft Corporation.

† *PSPICE* is a registered trademark of MicroSim Corporation.

**First-Generation Codec ac Interface Network: Resistive Termination**

The following reference circuit shows the complete SLIC schematic for interface to the Agere T7504 first-generation codec for a resistive termination impedance. For this example, the ac interface was designed for a 600 Ω resistive termination and hybrid balance with transmit gain and receive gain set to 0 dBm. For illustration purposes, no PPM injection was assumed in this example. This implies use of the default overhead voltage and no components for meter pulse rejection. Also, this example illustrates the device with a single battery operation and fixed overhead, current limit, and loop closure threshold. This is a lower feature application example.

Resistor  $R_{GN}$  is optional. It compensates for any mismatch of input bias voltage at the RCVN/RCVP inputs. If it is not used, there may be a slight offset at tip and ring due to mismatch of input bias voltage at the RCVN/RCVP inputs. It is very common to simply tie RCVN directly to ground in this particular mode of operation. If used, to calculate  $R_{GN}$ , the impedance from RCVN to ac ground should equal the impedance from RCVP to ac ground.

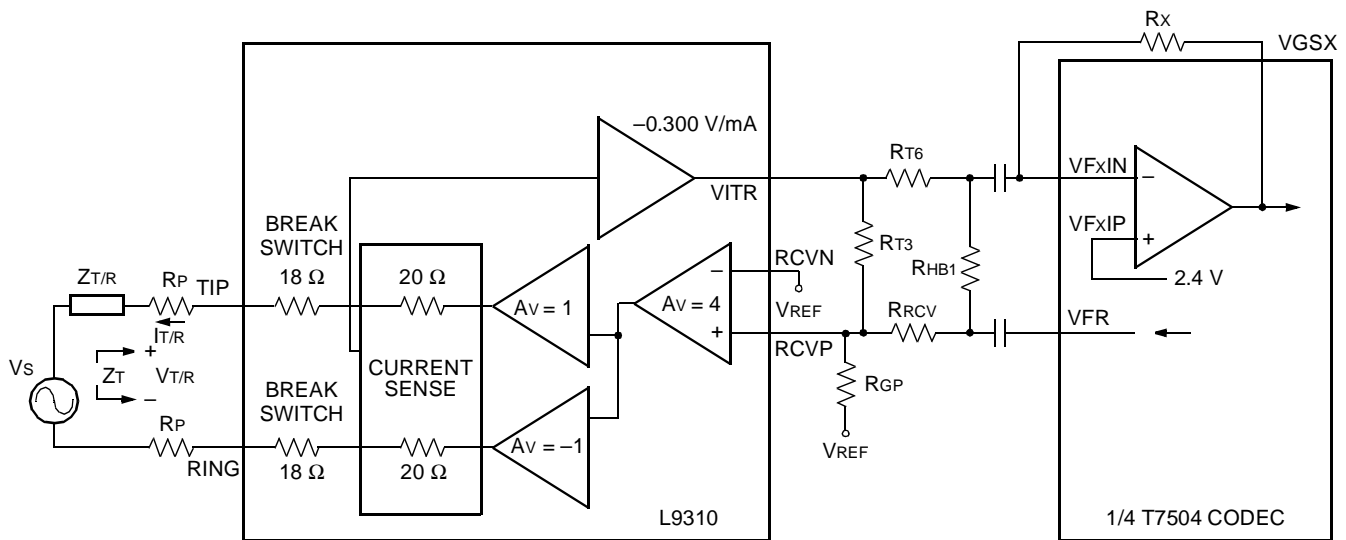

12-3580B (F)

**Figure 15. ac Equivalent Circuit**

## ac Applications (continued)

### First-Generation Codec ac Interface Network: Resistive Termination (continued)

#### Example 1, Real Termination

The following design equations refer to the circuit in Figure 15. Use these to synthesize real termination impedance.

#### Termination Impedance:

$$Z_T = \frac{V_{T/R}}{-I_{T/R}}$$

$$Z_T = 76 \Omega + 2R_P + \frac{2400}{1 + \frac{R_{T3}}{R_{GP}} + \frac{R_{T3}}{R_{RCV}}}$$

#### Receive Gain:

$$g_{rcv} = \frac{V_{T/R}}{V_{FR}}$$

$$g_{rcv} = \frac{8}{\left(1 + \frac{R_{RCV}}{R_{T3}} + \frac{R_{RCV}}{R_{GP}}\right) \left(1 + \frac{Z_T}{Z_{T/R}}\right)}$$

#### Transmit Gain:

$$g_{tx} = \frac{V_{GSX}}{V_{T/R}}$$

$$g_{tx} = \frac{-R_X}{R_{T6}} \times \frac{300}{Z_{T/R}}$$

#### Hybrid Balance:

$$h_{bal} = 20 \log \left( \frac{R_X}{R_{HB1}} - g_{tx} \times g_{rcv} \right)$$

$$h_{bal} = 20 \log \left( \frac{V_{GSX}}{V_{FR}} \right)$$

To optimize the hybrid balance, the sum of the currents at the VFX input of the codec op amp should be set to 0. The expression for ZHB becomes:

$$R_{HB}(k\Omega) = \frac{R_X}{g_{tx} \times g_{rcv}}$$

ac Applications (continued)

First-Generation Codec ac Interface Network: Resistive Termination (continued)

Example 1, Real Termination (continued)

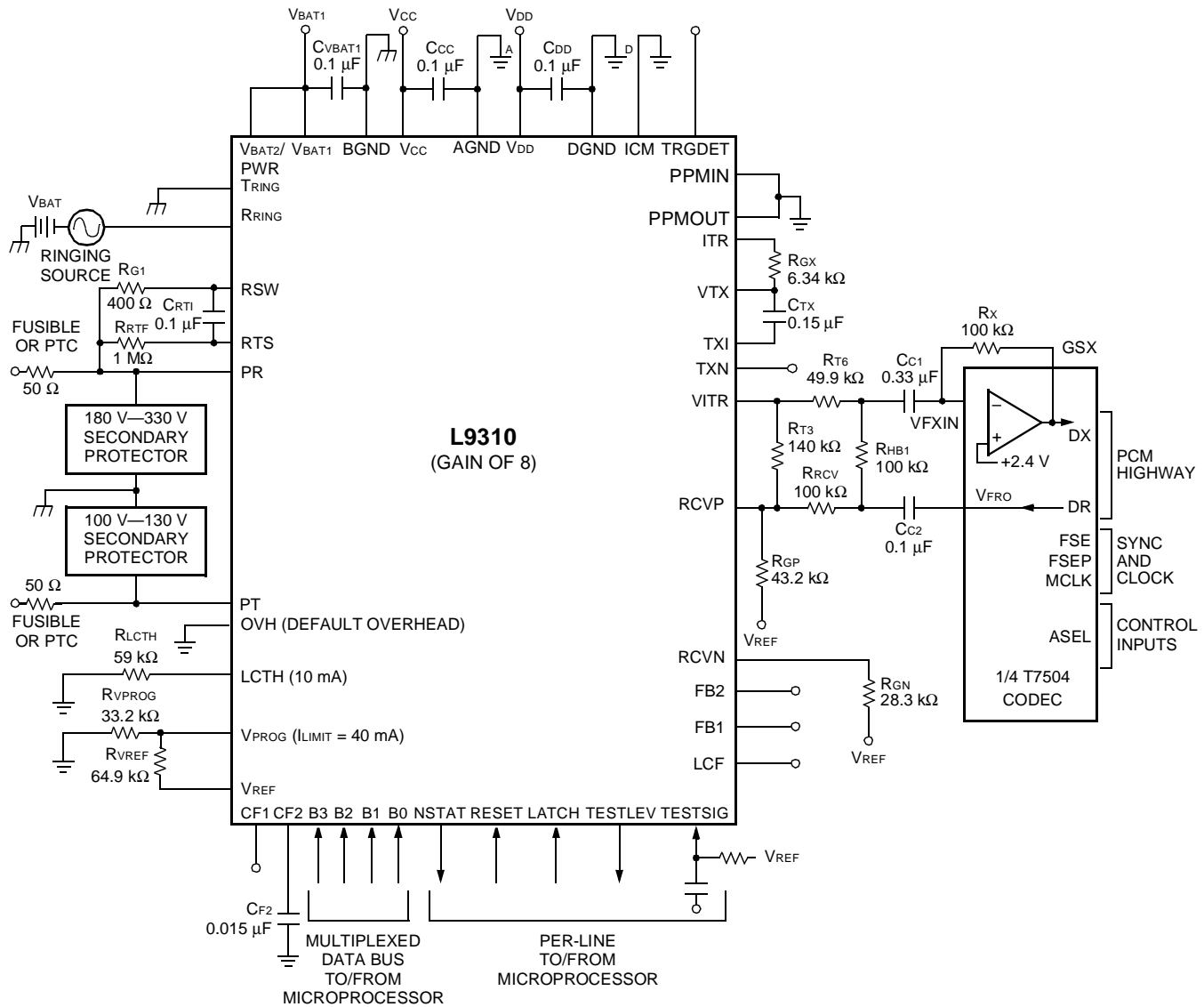

12-3521g (F)

- Notes:  
 Termination impedance = 600 Ω.  
 Hybrid balance = 600 Ω.  
 Tx = 0 dBm.  
 Rx = 0 dBm.

Figure 16. Agere T7504 First-Generation Codec Resistive Termination, Nonmeter Pulse Application, Single Battery Operation



**ac Applications** (continued)

**First-Generation Codec ac Interface Network: Resistive Termination** (continued)

**Example 1, Real Termination** (continued)

**Table 22. L9310 Parts List for Agere T7504 First-Generation Codec Resistive Termination, Nonmeter Pulse Application, Single Battery Operation**

Name	Value	Tolerance	Rating	Function
<b>Fault Protection</b>				
RPR	50 $\Omega$	1%	Fusible or PTC	Protection resistor.
RPT	50 $\Omega$	1%	Fusible or PTC	Protection resistor.
Protector*	180 V to 320 V	—	—	Ring-side secondary protector.
Protector*	100 V to 130 V	—	—	Tip-side secondary protector.
<b>Power Supply</b>				
CVBAT1	0.1 $\mu$ F	20%	100 V	Filter capacitor.
CCC	0.1 $\mu$ F	20%	10 V	Filter capacitor.
CDD	0.1 $\mu$ F	20%	10 V	Filter capacitor.
CF2	0.015 $\mu$ F	20%	100 V	Filter capacitor.
<b>dc Profile</b>				
RVPROG	33.2 k $\Omega$	1%	1/16 W	With RVREF fix dc current limit.
RVREF	64.9 k $\Omega$	1%	1/16 W	With RVPROG fix dc current limit.
<b>Supervision</b>				
CRTF	0.1 $\mu$ F	20%	100 V	Ring trip filter capacitor.
RRTF	1 M $\Omega$	1%	1/16 W	Ring trip filter resistor.
RRS1	400 $\Omega$	5%	2 W	Sets ring trip threshold.
RLCTH	59 k $\Omega$	1%	1/16 W	With RVREF, fix loop supervision threshold.
<b>ac Interface</b>				
RGX	6.34 k $\Omega$	1%	1/16 W	Sets T/R to VITR transconductance.
CTX	0.15 $\mu$ F	20%	10 V	ac/dc separation.
CC1	0.33 $\mu$ F	20%	10 V	dc blocking capacitor.
CC2	0.1 $\mu$ F	20%	10 V	dc blocking capacitor.
RT3	140 k $\Omega$	1%	1/16 W	With RGP and RRCV, sets termination impedance and receive gain.
RT6	49.9 k $\Omega$	1%	1/16 W	With RX, sets transmit gain.
RX	100 k $\Omega$	1%	1/16 W	With RT6, sets transmit gain.
RHB	100 k $\Omega$	1%	1/16 W	With RX, sets hybrid balance.
RRCV	100 k $\Omega$	1%	1/16 W	With RGP and RT3, sets termination impedance and receive gain.
RGP	43.2 k $\Omega$	1%	1/16 W	With RRCV and RT3, sets termination impedance and receive gain.
RGN Optional	28.3 k $\Omega$	1%	1/16 W	Optional. Compensates for input offset at RCVN/RCVP.

\* See your Agere Account Representative for a recommended secondary protection device.

**ac Applications** (continued)

**First-Generation Codec ac Interface Network: Complex Termination**

The following reference circuit shows the complete SLIC schematic for interface to the Agere T7504 first-generation codec for the German complex termination impedance. For this example, the ac interface was designed for a  $220 \Omega + (820 \Omega \parallel 115 \text{ nF})$  complex termination and hybrid balance with transmit gain and receive gain set to 0 dBm. For illustration purposes, 2.2 Vrms PPM injection was assumed in this example. This implies the overhead voltage is increased to 9.2 V and hybrid meter pulse rejection is used. Also, this example illustrates the device using the battery switch with multiple battery operation and fixed overhead, current limit, and loop closure threshold.

**Complex Termination Impedance Design**

Complex termination is specified in the form:

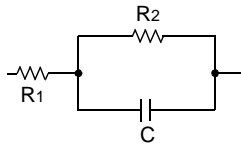

5-6396(F)

To work with this application, convert termination to the form:

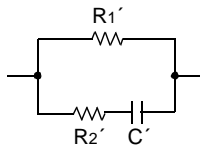

5-6398(F)

where:

$$R1' = R1 + R2$$

$$R2' = \frac{R1}{R2} (R1 + R2)$$

$$C' = \left( \frac{R2}{R1 + R2} \right)^2 C$$

**ac Interface Using First-Generation Codec**

$R_{TGP}/R_{TGS}/C_{GS}$  ( $Z_{TG}$ ): these components give gain shaping to get good gain flatness. These components are a scaled version of the specified complex termination impedance.

Note that for pure (600  $\Omega$ ) resistive terminations, components  $R_{TGS}$  and  $C_{GS}$  are not used. Resistor  $R_{TGP}$  is used and is still 6.34 k $\Omega$ .

$R_X/R_{T6}$ : with other components set, the transmit gain (for complex and resistive terminations)  $R_X$  and  $R_{T6}$  are varied to give specified transmit gain.

$R_{T3}/R_{RCV}/R_{GP}$ : for both complex and resistive terminations, the ratio of these resistors set the receive gain. For resistive terminations, the ratio of these resistors sets the return loss characteristic. For complex terminations, the ratio of these resistors set the low-frequency return loss characteristic.

$C_N/R_{N1}/R_{N2}$ : for complex terminations, these components provide high-frequency compensation to the return loss characteristic.

For resistive terminations, these components are not used and  $R_{CVN}$  is connected to ground via a resistor.

$R_{HB}$ : sets hybrid balance for all terminations.

**Set  $Z_{TG}$ —Gain Shaping**

$Z_{TG} = R_{TGP} \parallel R_{TGS} + C_{GS}$ , which is a scaled version of  $Z_{T/R}$  (the specified termination resistance), in the  $R1' \parallel R2' + C'$  form.

$R_{TGP}$  must be 6.34 k $\Omega$  to set SLIC transconductance to 300 V/A.

$$R_{TGP} = 6.34 \text{ k}\Omega$$

At dc,  $C_{GS}$  and  $C'$  are open.

$$R_{TGP} = M \times R1'$$

where M is the scale factor.

$$M = \frac{6340}{R1'}$$

It can be shown:

$$R_{TGS} = M \times R2'$$

and

$$C_{TGS} = \frac{C'}{M}$$

ac Applications (continued)

First-Generation Codec ac Interface Network: Complex Termination (continued)

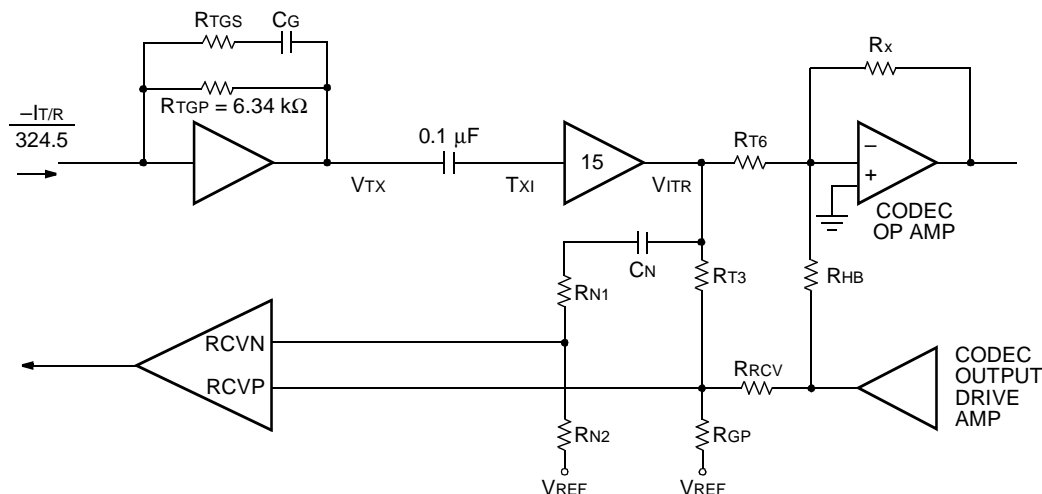

5-6400.M (F)

Figure 17. Interface Circuit Using First-Generation Codec (Blocking Capacitors Not Shown)

Transmit Gain

Transmit gain will be specified as a gain from T/R to PCM, Tx (dB). Since PCM is referenced to 600 Ω and assumed to be 0 dB, and in the case of T/R being referenced to some complex impedance other than 600 Ω resistive, the effects of the impedance transformation must be taken into account.

Again, specified complex termination impedance at T/R is of the form:

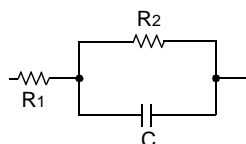

5-6396(F)

First, calculate the equivalent resistance of this network at the midband frequency of 1000 Hz.

$$R_{EQ} = \sqrt{\left( \frac{(2\pi f)^2 C^2 R_1 R_2^2 + R_1 + R_2}{1 + (2\pi f)^2 R_2^2 C^2} \right)^2 + \left( \frac{2\pi f R_2^2 C}{1 + (2\pi f)^2 R_2^2 C^2} \right)^2}$$

Using  $R_{EQ}$ , calculate the desired transmit gain, taking into account the impedance transformation:

$$T_x \text{ (dB)} = T_x \text{ (specified[dB])} + 20 \log \sqrt{\frac{600}{R_{EQ}}}$$

$T_x \text{ (specified[dB])}$  is the specified transmit gain. 600 Ω is the impedance at the PCM and  $R_{EQ}$  is the impedance at

tip and ring.  $20 \log \sqrt{\frac{600}{R_{EQ}}}$  represents the power loss/gain due to the impedance transformation.

Note in the case of a 600 Ω pure resistive termination

$$\text{at T/R } 20 \log \sqrt{\frac{600}{R_{EQ}}} = 20 \log \sqrt{\frac{600}{600}} = 0.$$

Thus, there is no power loss/gain due to impedance transformation and  $T_x \text{ (dB)} = T_x \text{ (specified[dB])}$ .

Finally, convert  $T_x \text{ (dB)}$  to a ratio,  $g_{TX}$ :

$$T_x \text{ (dB)} = 20 \log g_{TX}$$

The ratio of  $R_x/R_{T6}$  is used to set the transmit gain:

$$\frac{R_x}{R_{T6}} = g_{TX} \cdot \frac{324.5}{15} \cdot \frac{1}{M}$$

with a quad Agere codec such as T7504:

$$R_x < 200 \text{ k}\Omega$$

**ac Applications** (continued)

**First-Generation Codec ac Interface Network: Complex Termination** (continued)

**Receive Gain**

Ratios of  $R_{RCV}$ ,  $R_{T3}$ ,  $R_{GP}$  will set both the low-frequency termination and receive gain for the complex case. In the complex case, additional high-frequency compensation, via  $C_N$ ,  $R_{N1}$ , and  $R_{N2}$ , is needed for the return loss characteristic. For resistive termination,  $C_N$ ,  $R_{N1}$ , and  $R_{N2}$  are not used and  $R_{CVN}$  is tied to ground via a resistor.

Determine the receive gain,  $g_{RCV}$ , taking into account the impedance transformation in a manner similar to transmit gain.

$$R_X \text{ (dB)} = R_{X \text{ (specified[dB])}} + 20 \log \sqrt{\frac{R_{EQ}}{600}}$$

$$R_X \text{ (dB)} = 20 \log g_{RCV}$$

Then:

$$g_{RCV} = \frac{4}{1 + \frac{R_{RCV}}{R_{T3}} + \frac{R_{RCV}}{R_{GP}}}$$

and low-frequency termination

$$Z_{TER(low)} = \frac{2400}{1 + \frac{R_{T3}}{R_{GP}} + \frac{R_{T3}}{R_{RCV}}} + 2R_P + 76 \Omega$$

$Z_{TER(low)}$  is the specified termination impedance assuming low frequency ( $C$  or  $C'$  is open).

$R_P$  is the series protection resistor.

These two equations are best solved using a computer spreadsheet.

Next, solve for the high-frequency return loss compensation circuit,  $C_N$ ,  $R_{N1}$ , and  $R_{N2}$ :

$$C_N R_{N2} = \frac{(2R_P + 76 \Omega)}{2400} C_G R_{TGP}$$

$$R_{N1} = R_{N2} \left[ \frac{2400}{(2R_P + 76 \Omega)} \left( \frac{R_{TGS}}{R_{TGP}} \right) - 1 \right]$$

There is an input offset voltage associated with nodes  $R_{CVN}$  and  $R_{CVP}$ . To minimize the effect of mismatch of this voltage at T/R, the equivalent resistance to ac ground at  $R_{CVN}$  should be approximately equal to that at  $R_{CVP}$ .

**Hybrid Balance**

Set the hybrid cancellation via  $R_{HB}$ .

$$R_{HB} = \frac{R_X}{g_{RCV} \times g_{TX}}$$

ac Applications (continued)

First-Generation Codec ac Interface Network: Complex Termination (continued)

Blocking Capacitors

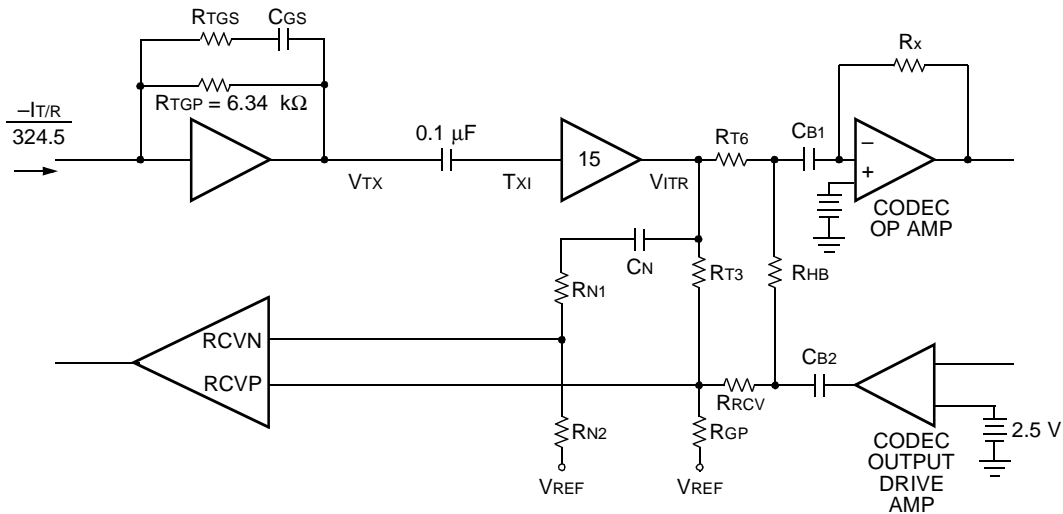

5-6401.K (F)

Figure 18. ac Interface Using First-Generation Codec (Including Blocking Capacitors) for Complex Termination Impedance

If a 5 V only codec such as the Agere T7504 is used, dc blocking capacitors must be added as shown in Figure 18. This is because the codec is referenced to 2.5 V and the SLIC to ground—with the ac coupling, a dc bias at T/R is eliminated and power associated with this bias is not consumed.

Typically, values of 0.1  $\mu\text{F}$  to 0.47  $\mu\text{F}$  capacitors are used for dc blocking. The addition of blocking capacitors will cause a shift in the return loss and hybrid balance frequency response toward higher frequencies, degrading the lower-frequency response. The lower

the value of the blocking capacitor, the more pronounced the effect is, but the cost of the capacitor is lower. It may be necessary to scale resistor values higher to compensate for the low-frequency response. This effect is best evaluated via simulation. A *PSPICE* model for the L9310 is available.

Design equation calculations seldom yield standard component values. Conversion from the calculated value to standard value may have an effect on the ac parameters. This effect should be evaluated and optimized via simulation.

ac Applications (continued)

First-Generation Codec ac Interface Network: Complex Termination (continued)

Basic Loop Start Application Using T7504 Type Codec

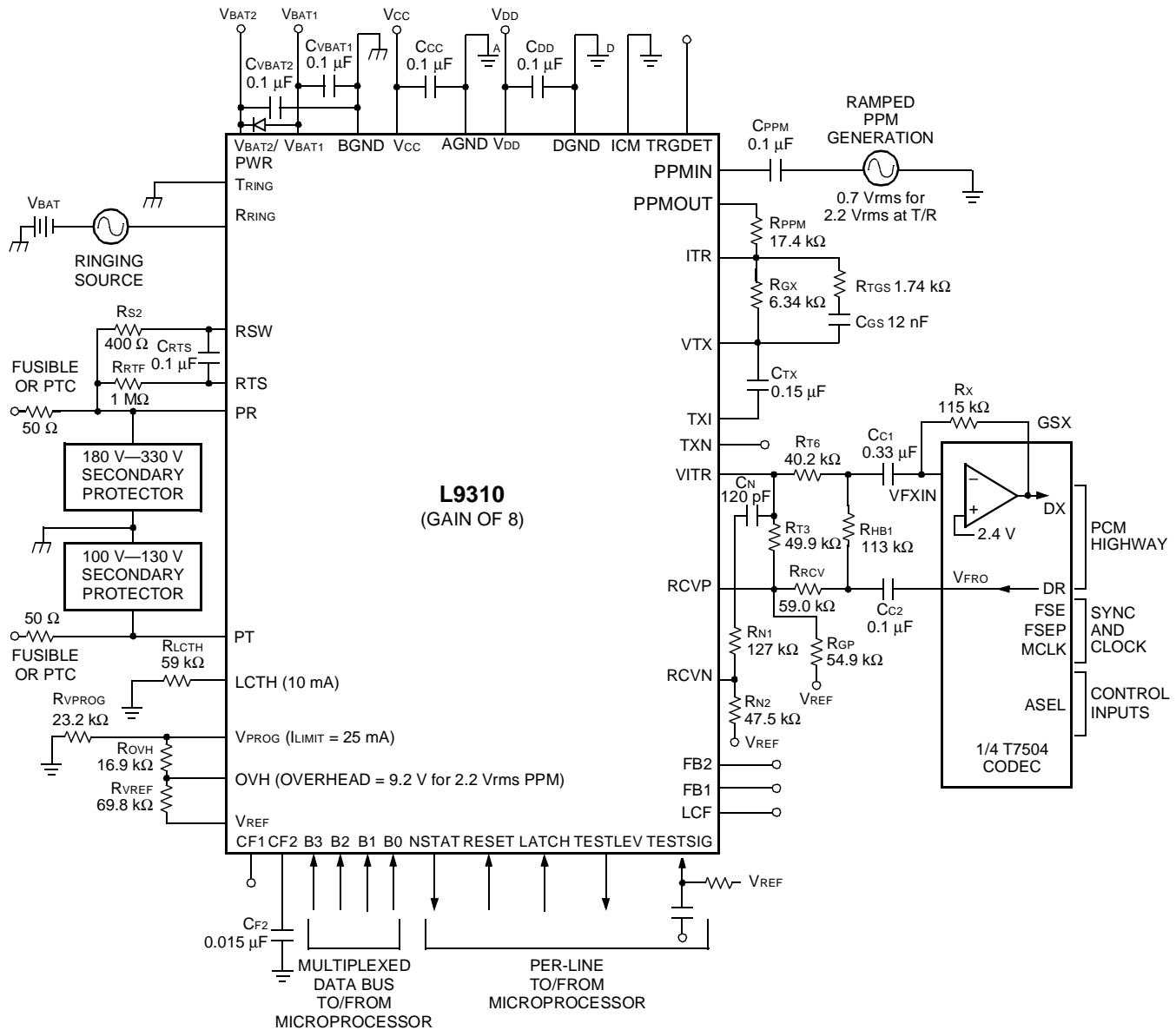

12-3528b (F)

- Notes:
- Termination impedance =  $220 \Omega + (820 \Omega \parallel 115 \text{ nF})$ .
  - Hybrid balance =  $220 \Omega + (820 \Omega \parallel 115 \text{ nF})$ .
  - Tx = 0 dBm.
  - Rx = 0 dBm.

Figure 19. Basic Loop Start Application Using T7504 Type Codec

**ac Applications** (continued)

**First-Generation Codec ac Interface Network: Complex Termination** (continued)

**Basic Loop Start Application Using T7504 Type Codec** (continued)

**Table 23. L9310 Parts List for Agere T7504 First-Generation Codec Complex Termination, Meter Pulse Application, Dual Battery Operation**

Name	Value	Tolerance	Rating	Function
<b>Fault Protection</b>				
RPR	50 $\Omega$	1%	Fusible or PTC	Protection resistor.
RPT	50 $\Omega$	1%	Fusible or PTC	Protection resistor.
Protector*	180 V to 320 V	—	—	Ring-side secondary protector.
Protector*	100 V to 130 V	—	—	Tip-side secondary protector.
<b>Power Supply</b>				
Diode	1N4004	—	—	Reverse battery current.
CVBAT1	0.1 $\mu$ F	20%	100 V	Filter capacitor.
CVBAT2	0.1 $\mu$ F	20%	50 V	Filter capacitor.
CCC	0.1 $\mu$ F	20%	10 V	Filter capacitor.
CDD	0.1 $\mu$ F	20%	10 V	Filter capacitor.
CF2	0.01 $\mu$ F	20%	100 V	Filter capacitor.
<b>dc Profile</b>				
RVPROG	23.2 k $\Omega$	1%	1/16 W	With RVREF fix dc current limit.
ROVH	16.9 k $\Omega$	1%	1/16 W	With RVREF fix overhead voltage.
RVREF	69.8 k $\Omega$	1%	1/16 W	With RVPROG fix dc current limit.
<b>Supervision</b>				
CRTF	0.1 $\mu$ F	20%	100 V	Ring trip filter capacitor.
RRTF	1 M $\Omega$	1%	1/16 W	Ring trip filter resistor.
RRS1	400 $\Omega$	5%	2 W	Sets ring trip threshold.
RLCTH	59 k $\Omega$	1%	1/16 W	With RVREF, fix loop supervision threshold.
<b>PPM</b>				
CPPM	0.01 $\mu$ F	20%	5 V	ac-couple PPM input.
RPPM	17.4 k $\Omega$	1%	1/16 W	PPM hybrid rejection.

\* See your Agere Account Representative for a recommended Secondary Protection Device.

**ac Applications** (continued)

**First-Generation Codec ac Interface Network: Complex Termination** (continued)

**Basic Loop Start Application Using T7504 Type Codec** (continued)

**Table 23. L9310 Parts List for Agere T7504 First-Generation Codec Complex Termination, Meter Pulse Application, Dual Battery Operation** (continued)

Name	Value	Tolerance	Rating	Function
<b>ac Interface</b>				
RGX	6.34 kΩ	1%	1/16 W	Sets T/R to VITR dc transconductance and gain shaping for complex termination.
RTGC RTGS	1.74 kΩ	1%	1/16 W	Gain shaping for complex termination.
CGS	12 nF	5%	10 V	Gain shaping for complex termination.
CTX	0.1 μF	20%	10 V	ac/dc separation.
CC1	0.47 μF	20%	10 V	dc blocking capacitor.
CC2	0.1 μF	20%	10 V	dc blocking capacitor.
RT3	49.9 kΩ	1%	1/16 W	With RGP and RRCV, sets termination impedance and receive gain.
RT6	40.2 kΩ	1%	1/16 W	With Rx, sets transmit gain.
RX	115 kΩ	1%	1/16 W	With RT6, sets transmit gain.
RHB	113 kΩ	1%	1/16 W	With Rx, sets hybrid balance.
RRCV	59.0 kΩ	1%	1/16 W	With RGP and RT3, sets termination impedance and receive gain.
RGP	54.9 kΩ	1%	1/16 W	With RRCV and RT3, sets termination impedance and receive gain.
CN	120 pF	20%	10 V	High-frequency compensation.
RN1	127 kΩ	1%	1/16 W	High-frequency compensation.
RN2	47.5 kΩ	1%	1/16 W	High-frequency compensation, compensate for dc offset at RCVP/RCVN.

\* See your Agere Account Representative for a recommended Secondary Protection Device.



ac Applications (continued)

Third-Generation Codec ac Interface Network: Complex Termination

The following reference circuit shows the complete SLIC schematic for interface to the Agere T8536 third-generation. All ac parameters are programmed by the T8536. Note that this codec differentiates itself in that no external components are required in the ac interface to provide a dc termination impedance or for stability. For illustration purposes, 2.2 Vrms PPM injection was assumed in this example, and hybrid meter pulse rejection is used. Also, this example illustrates the device using the battery switch with multiple battery operation and programmable overhead, current limit, and loop closure threshold. Please see the T8535/6 data sheet for information on coefficient programming.

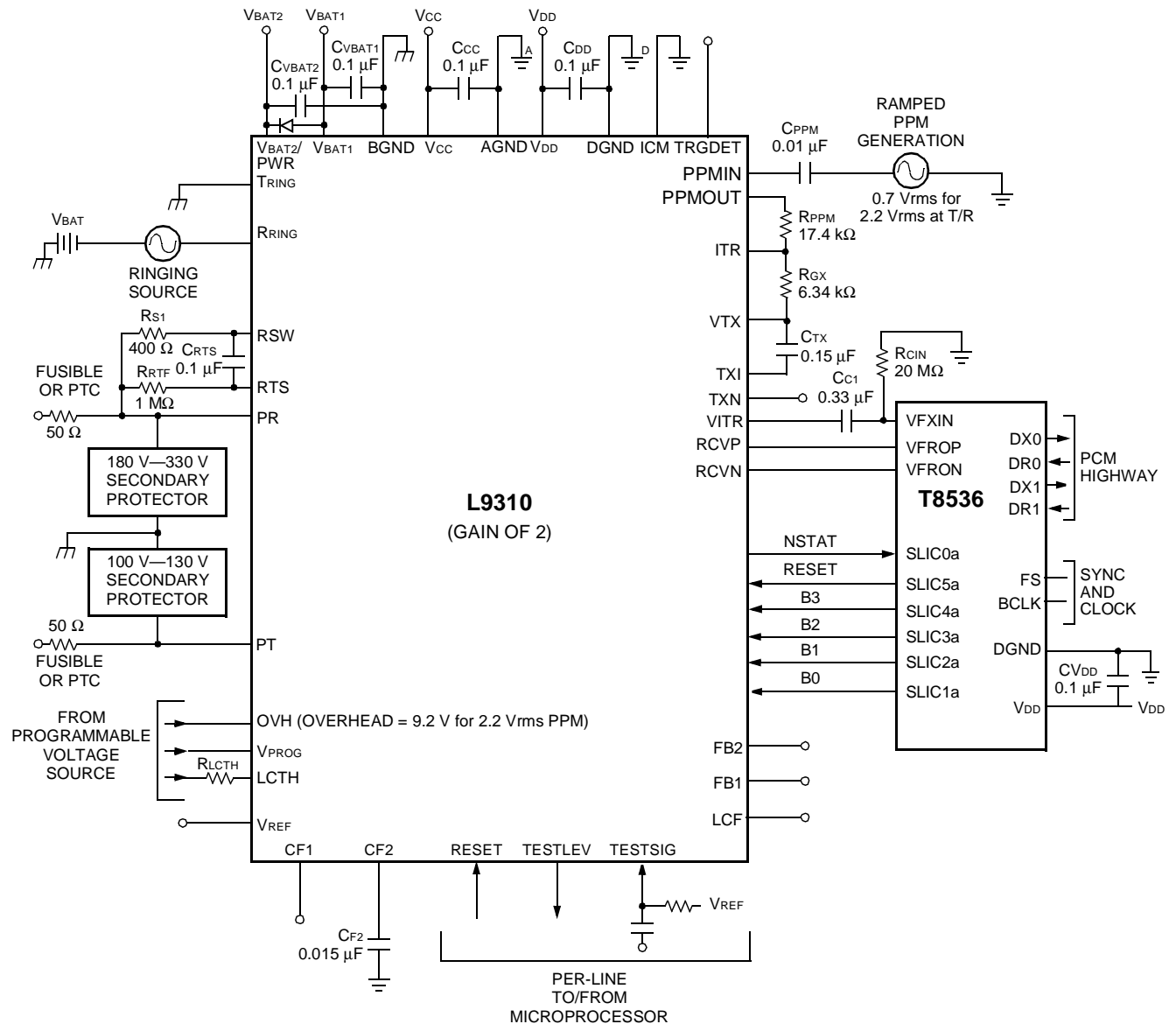

12-3527f (F)

Figure 20. L9310 for Agere T8536 Third-Generation Codec Meter Pulse Application, Dual Battery Operation, ac and dc Parameters, Fully Programmable

**ac Applications** (continued)

**Third-Generation Codec ac Interface Network: Complex Termination** (continued)

**Table 24. L9310 Parts List for Agere T8536 Third-Generation Codec Meter Pulse Application, Dual Battery Operation, ac and dc Parameters, Fully Programmable**

Name	Value	Tolerance	Rating	Function
<b>Fault Protection</b>				
RPR	50 $\Omega$	1%	Fusible or PTC	Protection resistor.
RPT	50 $\Omega$	1%	Fusible or PTC	Protection resistor.
Protector*	180 V to 320 V	—	—	Ring-side secondary protector.
Protector*	100 V to 130 V	—	—	Tip-side secondary protector.
<b>Power Supply</b>				
Diode	1N4004	—	—	Reverse battery current.
CVBAT1	0.1 $\mu$ F	20%	100 V	Filter capacitor.
CVBAT2	0.1 $\mu$ F	20%	50 V	Filter capacitor.
CCC	0.1 $\mu$ F	20%	10 V	Filter capacitor.
CDD	0.1 $\mu$ F	20%	10 V	Filter capacitor.
CF2	0.015 $\mu$ F	20%	100 V	Filter capacitor.
<b>Supervision</b>				
CRTF	0.1 $\mu$ F	20%	100 V	Ring trip filter capacitor.
RRTF	1 M $\Omega$	1%	1/16 W	Ring trip filter resistor.
RRS1	400 $\Omega$	5%	2 W	Sets ring trip threshold.
<b>PPM</b>				
CPPM	0.01 $\mu$ F	20%	5 V	ac couple PPM input.
RPPM	17.4 k $\Omega$	1%	1/16 W	PPM hybrid rejection.
<b>ac Interface</b>				
RGX	6.34 k $\Omega$	1%	1/16 W	Sets T/R to VITR transconductance.
RCIN	20 M $\Omega$	5%	1/16 W	dc bias.
CTX	0.15 $\mu$ F	20%	10 V	ac/dc separation.
CC1	0.33 $\mu$ F	20%	10 V	dc blocking capacitor.

\* See your Agere Account Representative for a recommended secondary protection device.

## Outline Diagram

### 44-Pin PLCC

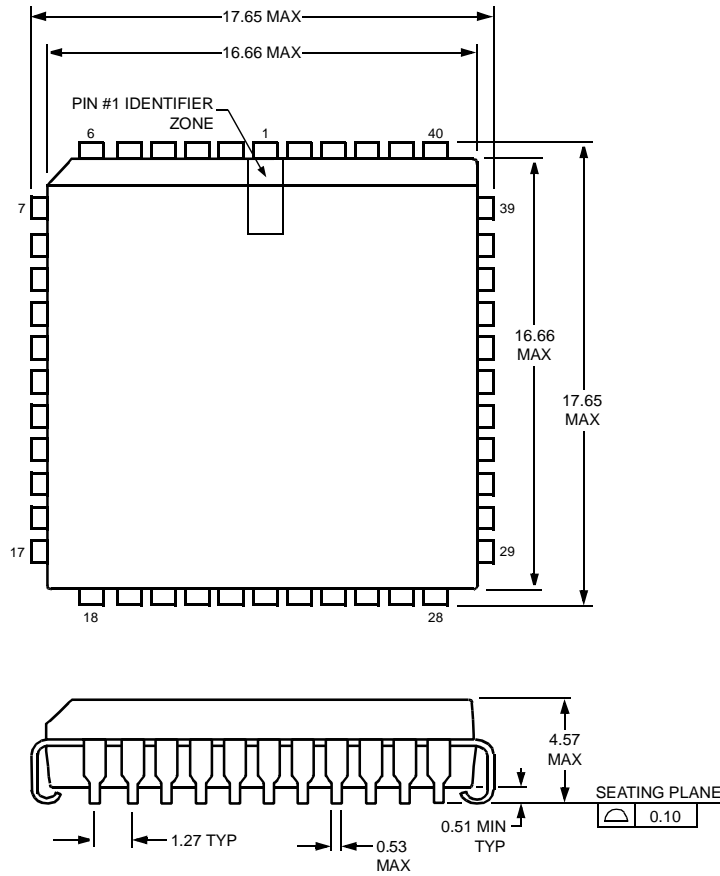

5-2506F

## Ordering Information

Device Part Number	Package	Comcode
LUCL9310AP-D	44-Pin PLCC, Dry-bagged	108326729
LUCL9310AP-DT	44-Pin PLCC, Dry-bagged, Tape and Reel	108326737
LUCL9310GP-D	44-Pin PLCC, Dry-bagged	108417866
LUCL9310GP-DT	44-Pin PLCC, Dry-bagged, Tape and Reel	108417874

For additional information, contact your Agere Systems Account Manager or the following:

INTERNET: <http://www.agere.com>

E-MAIL: [docmaster@micro.lucent.com](mailto:docmaster@micro.lucent.com)

N. AMERICA: Agere Systems Inc., 555 Union Boulevard, Room 30L-15P-BA, Allentown, PA 18109-3286  
**1-800-372-2447**, FAX 610-712-4106 (In CANADA: **1-800-553-2448**, FAX 610-712-4106)

ASIA PACIFIC: Agere Systems Singapore Pte. Ltd., 77 Science Park Drive, #03-18 Cintech III, Singapore 118256  
**Tel. (65) 778 8833**, FAX (65) 777 7495

CHINA: Agere Systems (Shanghai) Co., Ltd., 33/F Jin Mao Tower, 88 Century Boulevard Pudong, Shanghai 200121 PRC  
**Tel. (86) 21 50471212**, FAX (86) 21 50472266

JAPAN: Agere Systems Japan Ltd., 7-18, Higashi-Gotanda 2-chome, Shinagawa-ku, Tokyo 141, Japan  
**Tel. (81) 3 5421 1600**, FAX (81) 3 5421 1700

EUROPE: Data Requests: DATALINE: **Tel. (44) 7000 582 368**, FAX (44) 1189 328 148

Technical Inquiries: GERMANY: **(49) 89 95086 0** (Munich), UNITED KINGDOM: **(44) 1344 865 900** (Ascot),

FRANCE: **(33) 1 40 83 68 00** (Paris), SWEDEN: **(46) 8 594 607 00** (Stockholm), FINLAND: **(358) 9 3507670** (Helsinki),

ITALY: **(39) 02 6608131** (Milan), SPAIN: **(34) 1 807 1441** (Madrid)

Agere Systems Inc. reserves the right to make changes to the product(s) or information contained herein without notice. No liability is assumed as a result of their use or application.