

Digital Audio Delay

General Description

The NJU26902 is a digital audio delay. The NJU26902 provides delay-time adjustment function and digital audio interface.

Package

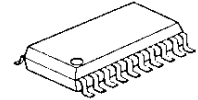

NJU26902V

FEATURES

- 2-Channel Audio Delay (24 bits data width).
Delay Time 85msec at fs = 48kHz (128msec at fs = 32kHz , 43msec at fs = 96kHz)
- To make longer delay time, the NJU26902 can be connected serially.
- Non-audio-signal data can be delayed by the NJU26902.

Hardware Specification

- | | | |
|-----------------------------------|---|--|
| • Digital Audio Interface | : | 1 Input port, 1 Output port |
| • Digital Audio Format | : | LJ / RJ / I ² S 24bit BCK : 64fs / 32fs, Slave Mode |
| • Audio Bit Clock (BCK) Frequency | : | 13MHz Max (approximate fs=200KHz) |
| • Package | : | SSOP20 (Pb-Free) |
| • Power Supply | : | 2.5V (+3.3V input tolerant) |

Function Block Diagram

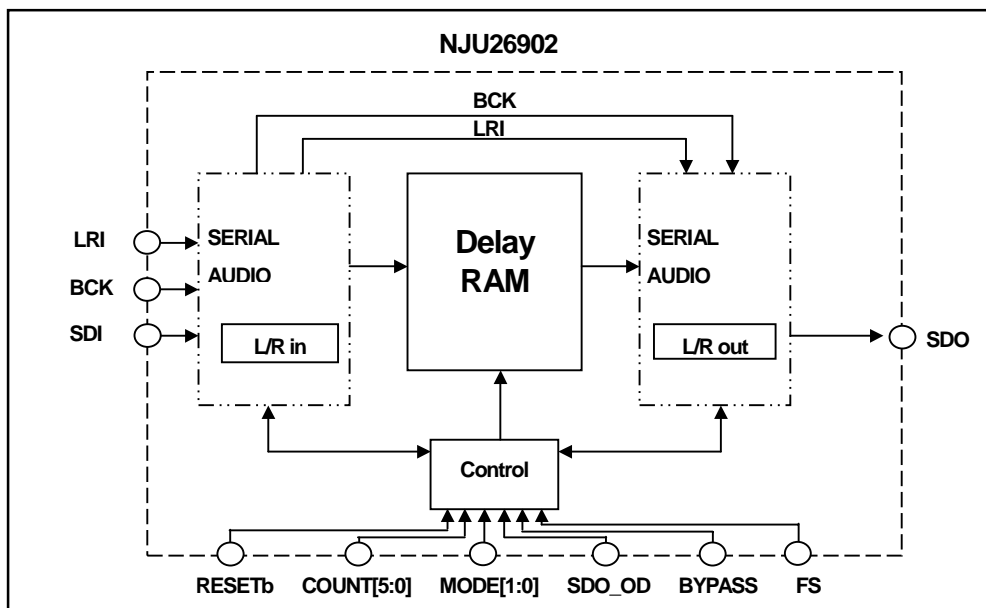

Fig. 1 Function Block Diagram

■ Pin Assignment

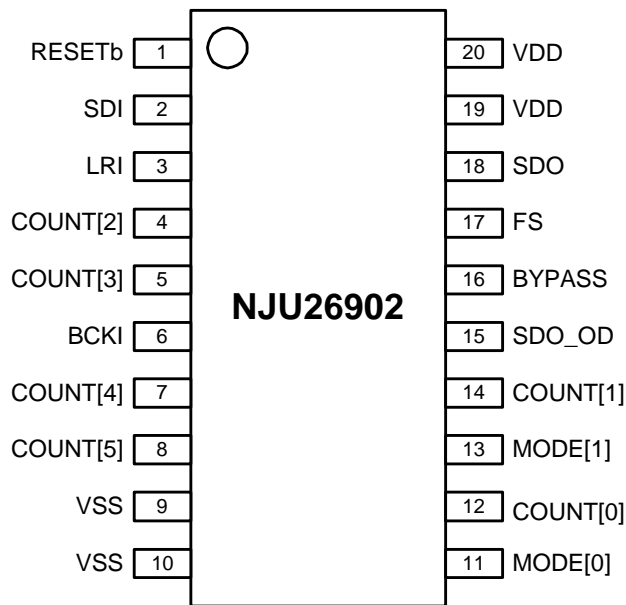

Fig. 2 Pin Assignment

■ Pin Description

Table 1 Pin Description

No.	Symbol	I/O	Description
1	RESETb	lpu	Reset (Active low)
2	SDI	l	Audio Data Input
3	LRI	l	LR Clock Input
4	COUNT[2]	lpu	Delay Time Control 2
5	COUNT[3]	lpu	Delay Time Control 3
6	BCKI	l	Bit Clock Input
7	COUNT[4]	lpu	Delay Time Control 4
8	COUNT[5]	lpu	Delay Time Control 5
9	VSS	-	GND
10	VSS	-	GND
11	MODE[0]	lpd	Digital Audio Interface Format Select
12	COUNT[0]	lpu	Delay Time Control 0
13	MODE[1]	lpu	Digital Audio Interface Format Select
14	COUNT[1]	lpu	Delay Time Control 1
15	SDO_OD	lpd	SDO pin Open Drain Select
16	BYPASS	lpd	SDO pin BYPASS Control
17	FS	lpu	BCK fs Select
18	SDO	O	Audio Data Output (CMOS Output / Open Drain Output)
19	VDD	-	Power Supply +2.5V
20	VDD	-	Power Supply +2.5V

- * l : Input
 lpu : Input (internal pull-up)
 lpd : Input (internal pull-down)
 O : Output

■ Absolute Maximum Ratings

Table2 Absolute Maximum Ratings (V_{SS}=0V, Ta=25°C)

Parameter	Symbol	Rating	Units
Power Supply Voltage	V _{DD}	-0.3 to +3.05	V
Input Pin Voltage	V _{TMI}	-0.3 to +3.6 (V _{DD} ≥ 2.25V) -0.3 to +3.05 (V _{DD} < 2.25V)	V
SDO Pin Voltage * (CMOS Output)	V _{TMO}	-0.3 to +3.05	V
SDO Pin Voltage * (Open Drain Output)	V _{TMOD}	-0.3 to +3.6 (V _{DD} ≥ 2.25V) -0.3 to +3.05 (V _{DD} < 2.25V)	V
Power Dissipation	P _D	300	mW
Operating Temperature	T _{OPR}	-40 to +85	°C
Storage Temperature	T _{STR}	-40 to +125	°C

* This specification is applied to V_{TMO} at the SDO pin in case of SDO_OD= Low".

■ Electric Characteristics

Table 3 Electric Characteristics

($V_{DD}=2.5V, V_{SS}=0V, T_a=25^{\circ}C$)

Parameter	Symbol	Test Condition	Min.	Typ.	Max.	Units
Operating V_{DD} Voltage	V_{DD}		2.25	2.5	2.75	V
Operating Current	I_{DD}	BCKI:13MHz SDO:C _L =25pF	-	1.0	-	mA
Operating Temperature	T_{OPR}		-40	25	85	°C
High Level Input Voltage	V_{IH}		2.0	-	3.3	V
Low Level Input Voltage	V_{IL}		-	-	0.5	V
High Level Output Voltage (SDO_OD="Low")	V_{OH}	$I_{OH} = -2mA$ $I_{OH} = -100\mu A$	$V_{DD}-0.4$ $V_{DD}-0.1$	-	V_{DD} V_{DD}	V
Low Level Output Voltage	V_{OL}	$I_{OL} = 2mA$ $I_{OL} = 100\mu A$	0 0	-	0.4 0.1	V
Open Drain Output Current (SDO_OD="High")	I_{OD}	$V_{IN} = 3.3V$	-15	-	+15	μA
Input Current	I_{IN}	$V_{IN} = V_{SS} \text{ to } 3.3V$	-15	-	+15	μA
Input Current (Internal Pull-up Pin)	$I_{IN(PU)}$	$V_{IN} = V_{SS} \text{ to } 3.3V$	-100	-	+15	μA
Input Current (Internal Pull-down Pin)	$I_{IN(PD)}$	$V_{IN} = V_{SS} \text{ to } 3.3V$	-15	-	+200	μA
Input Capacitance	C_{IN}		-	10	-	pF
Input Rise/Fall transition Time	t_r / t_f		-	-	100	ns

■ Equivalent Circuit

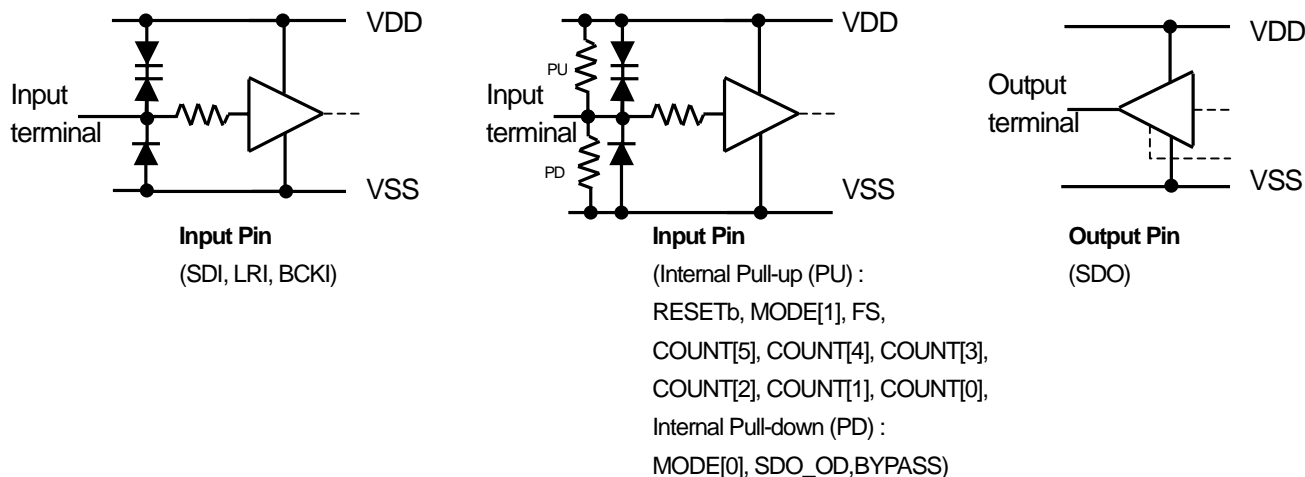

Fig. 3 I/O Equivalent Circuits

Serial Audio Timing

Table 4 Serial Audio Input Timing Parameters ($V_{DD}=2.5V, V_{SS}=0V, T_a=25^\circ C$)

Parameter	Symbol	Test Condition	Min	Typ.	Max	Units
BCKI Frequency	f_{BCK}		-	-	13	MHz
BCKI Period						
L Pulse Width	t_{SIL}		35	-	-	ns
H Pulse Width	t_{SIH}		35	-	-	ns
BCKI to LRI Time	T_{SLI}		15	-	-	ns
LRI to BCKI Time	t_{LSI}		15	-	-	ns
Data Setup Time	t_{DS}		15	-	-	ns
Data Hold Time	t_{DH}		15	-	-	ns
Data Output Delay	t_{DOD}	SDO: $C_L=25pF$ SDO_OD="Low"		-	15	ns

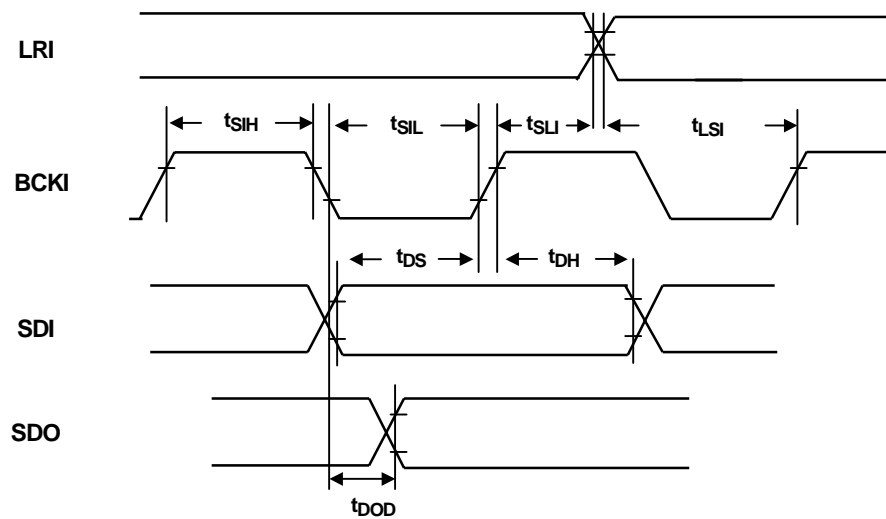

Fig. 4 Serial Audio Input / Output Timing

Serial Audio Interface

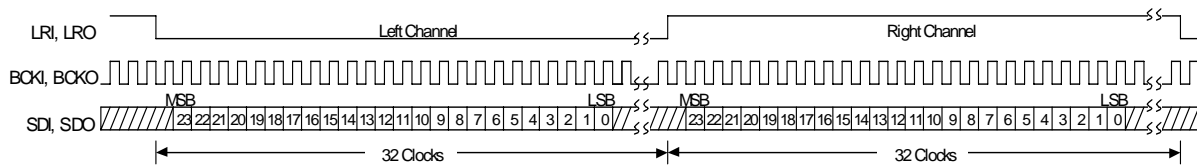

Fig. 5-1 I²S Data Format 64fs, 24bit Data

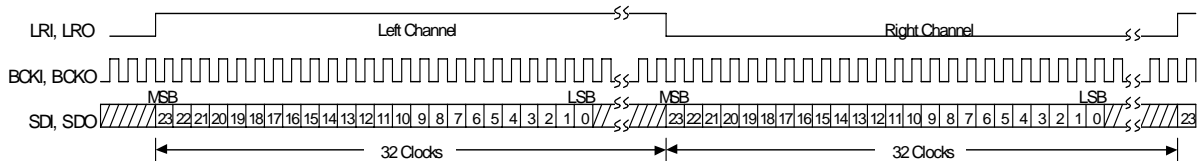

Fig. 5-2 Left-Justified Data Format 64fs, 24bit Data

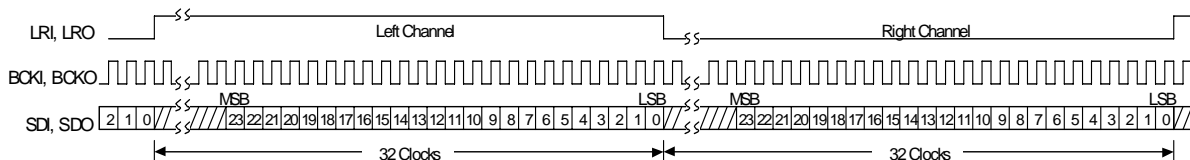

Fig. 5-3 Right-Justified Data Format 64fs, 24bit Data

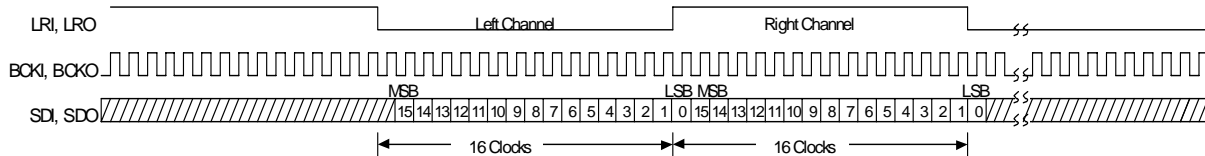

Fig. 5-4 I²S Data Format 32fs, 16bit Data

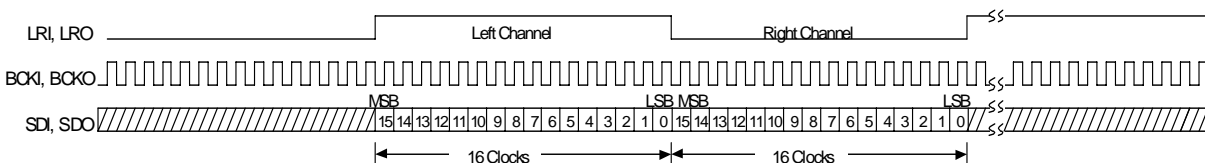

Fig. 5-5 Left-Justified Data Format 32fs, 16bit Data

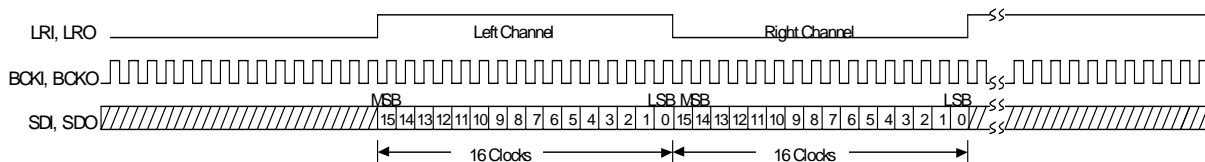

Fig. 5-6 Right-Justified Data Format 32fs, 16bit Data

■ Function Description

- SDI(#2) is the serial audio input pin. The input audio signal should be connected to this pin.
- LRI(#3) is the LR clock input pin. The LR clock frequency is the as same as of the input audio signal. In case of I²S format, if LRI="Low" SDI and SDO data are left channel data, if LRI="High" SDI and SDO data are right channel data.
- BCKI(#6) is the bit clock input pin. This BCKI clock frequency is 32 times (32fs) or 64 times (64fs) of the input audio signal frequency. The bit precision is 16-bit at 32 fs mode, and 24-bit at 64fs mode.
- MODE [1:0](#13,#11) and FS(#17) pins are used to select serial audio format. Refer to Table 5 "Mode pin, FS pin Setup" for details.
- SDO(#18) is the serial audio output pin. The delayed audio data come out through this pin.
- SDO is as the 2.5V CMOS output in case of SDO_OD(#15)= "Low". SDO is as the open drain output in case of SDO_OD= "High", SDO can be pulled up to 3.3V. In case of SDO_OD= "Low" & BYPASS= "High", the bypass mode is selected.
- The next combination is reserved. Do not use this combination. SDO_OD= "High" & BYPASS= "High". Refer to Table 6 "SDO_OD pin, BYPASS pin Setup" for details.
- COUNT [5:0](#8, #7, #5, #4, #14, #12) pins are used to select delay time. When the setup is changed, SDO outputs a "Low" level (mute) during the period selected by COUNT [5:0]. Refer to 4. Delay Time for details.
- When RESETb is "Low", the NJU26902 is initialized on the rising edge of BCKI. SDO outputs "Low" level (mute) voltage during the period selected by COUNT [5:0].
- In case of not using RESETb, connect RESETb to VDD.
- VDD is the power supply pin. Connect VDD to the 2.5V power supply. VSS is the GND pin. The decoupling capacitor is necessary between VDD and VSS.
- The input pins can interface with 3.3V ICs. Refer to Table 3 "Electric Characteristics" for details.
- After Power supply or serial audio format changing, there is possibility the NJU26902 generates random data for the delay time during the period set by COUNT[5:1] pins. If necessary, the mute circuit should be added or reset the NJU26902.

Table 5 Mode pin, FS pin Setup

FS (17pin)	MODE[1] (13pin)	MODE[0] (11pin)	Setup
0	0	0	RJ 16bit 32fs
0	0	1	LJ 16bit 32fs
0	1	0	I ² S 16bit 32fs
1	0	0	RJ 24bit 64fs
1	0	1	LJ 24bit 64fs
1	1	0	I ² S 24bit 64fs
Other			Reserved *1

* : 0=Low, 1=High

*1 : Do not use.

Table 6 SDO_OD pin, BYPASS pin Setup

SDO_OD (15pin)	BYPASS (16pin)	NJU26902 Function
0	0	Delay Operation, SDO=CMOS Output
0	1	Bypass Operation, SDO=CMOS Output
1	0	Delay Operation, SDO=Open Drain Output
1	1	Reserved *1

* : 0=Low, 1=High

*1 : Do not use.

■ Delay Time

- The NJU26902 provides maximum 4097 samples delay and slave-mode audio interface. The delay time depends on sampling frequency.
- The next formula shows how to calculate the delay time. Refer to Table 7 "Delay Sample Number Setup Example".

Total delay sample number =

$$\text{COUNT}[0]*2048+\text{COUNT}[1]*1024+\text{COUNT}[2]*512+\text{COUNT}[3]*256+\text{COUNT}[4]*128+\text{COUNT}[5]*64+64+1$$

Table 7 Delay Sample Number Setup Example

Pin No.	Symbol	Count	Setting								
			0	0	~	0	~	1	~	1	1
12	COUNT[0]	2048	0	0	~	0	~	1	~	1	1
14	COUNT[1]	1024	0	0		1		1		1	1
4	COUNT[2]	512	0	0	~	1	~	0	~	1	1
5	COUNT[3]	256	0	0		0		0		1	1
7	COUNT[4]	128	0	0	~	0	~	0	~	1	1
8	COUNT[5]	64	0	1		0		1		0	1
Total Delay Sample Number			65 (min.)	129	~	1601	~	3201	~	4033	4097 (max.)

Table 8 Sampling Frequency, Delay Sample Number Setup and Delay Time

Fs	Delay Time (ms)									Delay Sample Number
	65 (min.)	129	~	1601	~	3201	~	4033	4097 (max.)	
192kHz	0.3ms	0.7ms	~	8.3ms	~	16.7ms	~	21.0ms	21.3ms	
96kHz	0.7ms	1.3ms		16.7ms		33.3ms		42.0ms	42.7ms	
88.2kHz	0.7ms	1.5ms		18.2ms		36.3ms		45.7ms	46.5ms	
48kHz	1.4ms	2.7ms		33.4ms		66.7ms		84.0ms	85.4ms	
44.1kHz	1.5ms	2.9ms		36.3ms		72.6ms		91.5ms	92.9ms	
32kHz	2.0ms	4.0ms		50.0ms		100.0ms		126.0ms	128.0ms	

■ Package Dimensions (SSOP20, Pb-Free)

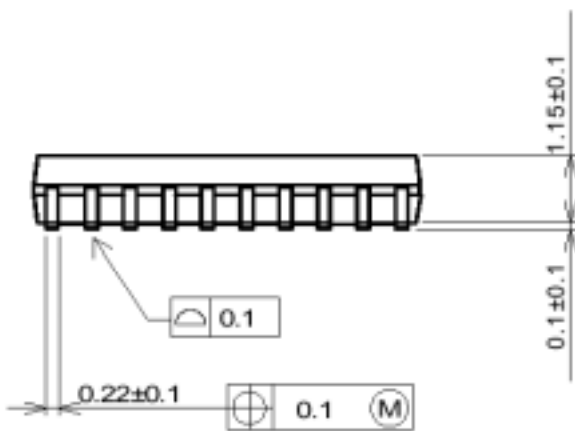
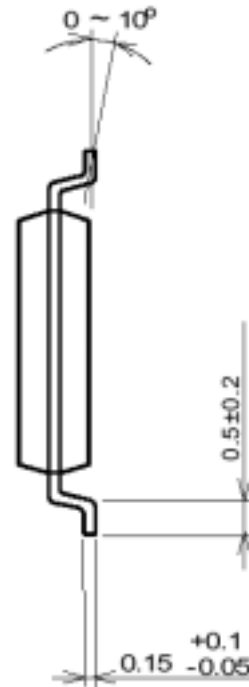
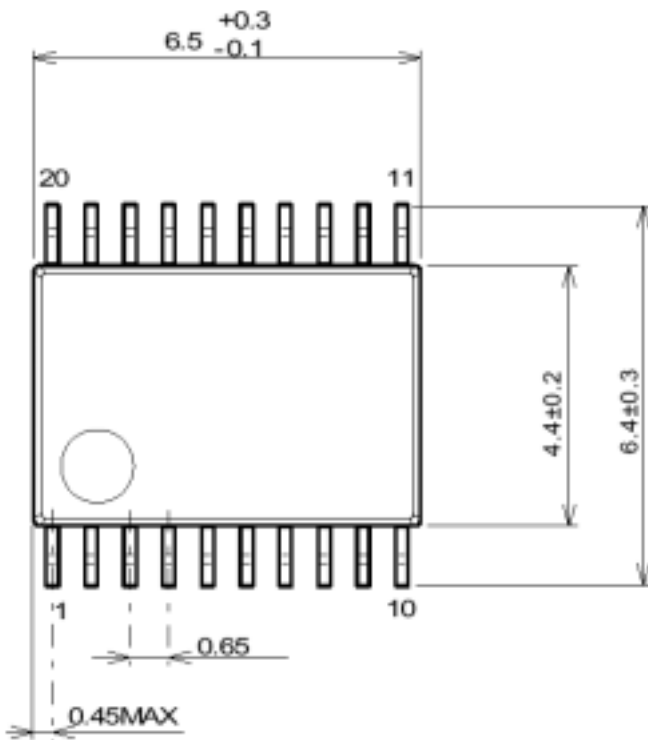

UNIT : mm

[CAUTION]

The specifications on this databook are only given for information, without any guarantee as regards either mistakes or omissions. The application circuits in this databook are described only to show representative usages of the product and not intended for the guarantee or permission of any right including the industrial rights.

Mouser Electronics

Authorized Distributor

Click to View Pricing, Inventory, Delivery & Lifecycle Information:

[NJR:](#)

[NJU26902V-TE1](#) [NJU26902VM1-TE2](#)