

THIS DRAWING IS UNPUBLISHED. RELEASED FOR PUBLICATION
 © COPYRIGHT - By - ALL RIGHTS RESERVED.

LOC		DIST		REVISIONS			
P	LTR	DESCRIPTION		DATE	DWN	APVD	
AF	50	E		REVISED PER ECR-12-013518	26NOV2012	KH PD	

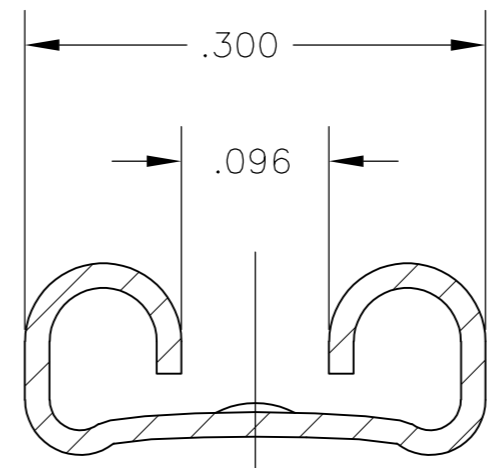

SECTION C-C

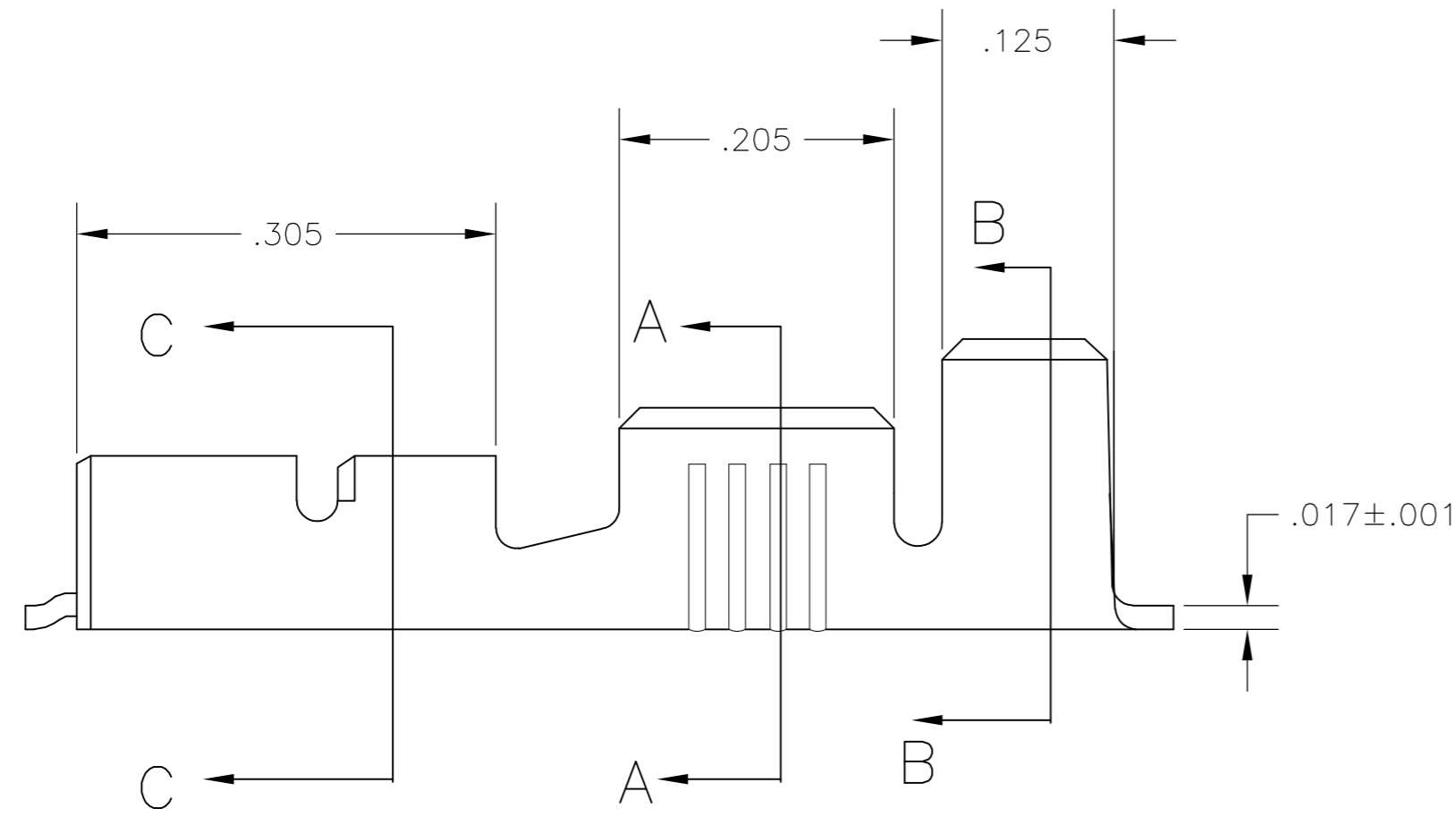
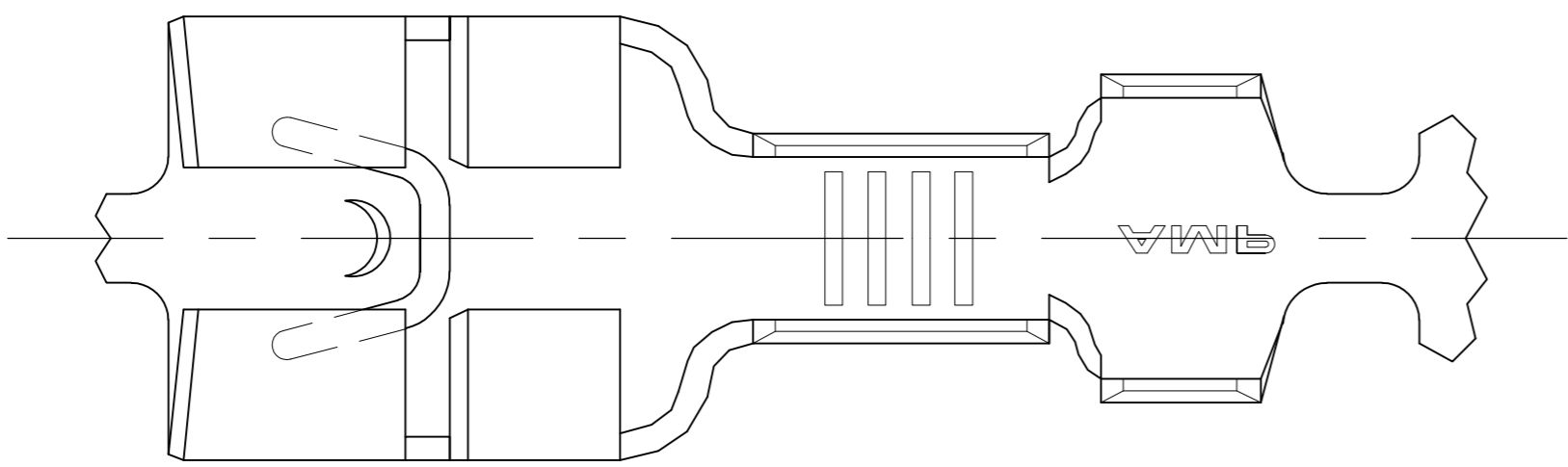
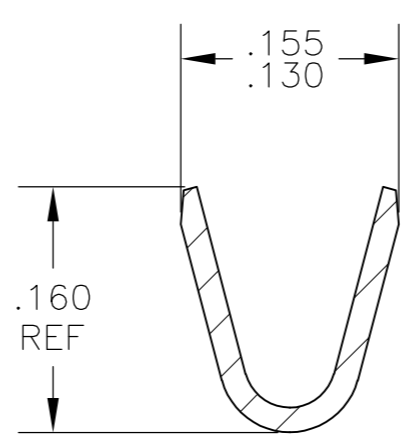

SECTION A-A

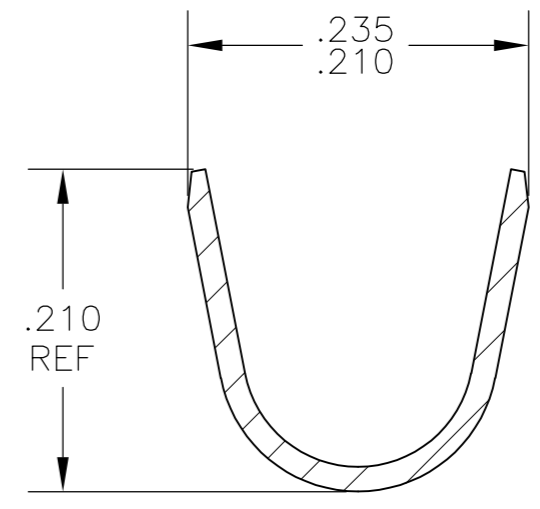

SECTION B-B

- 1 CONTINUOUS STRIP ON REELS
- 2 ACCEPTS #18-#14 AWG WIRE SIZE
CRIMP WIDTH, .120, F TYPE
- 3 INSULATION RANGE IS .120-.170 DIA
CRIMP WIDTH, .180, F OR O TYPE
- 4 MATING TAB THK IS .032±.001.
- 5 OBSOLETE PARTS: OBSOLETE CIS STREAMLINING
PER D.RENAUD/D.SINISI

5	OBSOLETE	-	1217917-2
		.000080 MIN TIN	1217917-1
		FINISH	PART NO

THIS DRAWING IS A CONTROLLED DOCUMENT.		DWN	JR RUTH	22JAN03	 TE Connectivity RECEPTACLE, FASTON, .250 SERIES							
DIMENSIONS: INCHES		CHK	P DESANTIS	11NOV03								
TOLERANCES UNLESS OTHERWISE SPECIFIED:		APVD	P DESANTIS	22JAN03								
0 PLC ± - 1 PLC ± - 2 PLC ± - 3 PLC ± .010 4 PLC ± - ANGLES ± - FINISH SEE TABLE		PRODUCT SPEC	-									
MATERIAL	BRASS	APPLICATION SPEC	-		SIZE	A2	CAGE CODE	00779	DRAWING NO	C=1217917	RESTRICTED TO	-
CUSTOMER DRAWING		WEIGHT	-		SCALE	1:1	SHEET	1 of 1	REV	E		

1217917