

Plug-in Detector for Type-C Connector

Features

- Compatible to USB Type-C™ Specification 1.1
- Backward compatible to USB Type-C Specification 1.0
- Supports Host mode/Device mode/Dual-role mode
- Supports Dual-role modes with/without Try.SNK/Try.SRC supported
- Auto-configure ports orientation through CC detection
- Supports both pin control and I2C interface for control and communication
- Integrated high-precision resistors and current sources for CC pins
- Provides support for Default current, 1.5A and 3A modes with I2C control
- Power saving mode
- Output indicator for plug-in detection
- Wide power supply range : 2.7V – 5.5V
- Industrial Temperature Range: -40°C to 85°C
- Packaging (Pb-free & Green):
 - 12- contact, STQFN(1.6mm x1.6mm)

Applications

- Notebooks
- Mobile Phones
- Tablets
- Docking Station

Pin Configuration

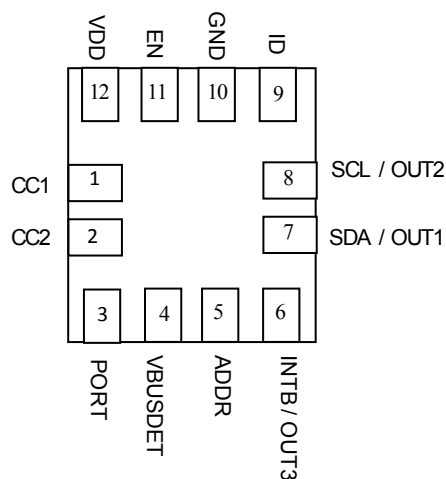

Figure 1. Pin Assignment (Top)

Description

Pericom Semiconductor's PI5USB30216D provides a cost-effective solution for USB 3.0 Type-C connector applications. PI5USB30216D detects the plug-in orientation of the cable at a Type-C connector. It supports host mode, device mode and dual role mode ports with automatic configuration based on the voltage levels detected on CC pins. It is a fully-integrated solution with ultra-low power dissipation. PI5USB30216D enters power-saving mode when EN pin is pulled down to GND through an internal resistor.

PI5USB30216D supports both pin and I²C control base on ADDR pin setting. It allows the system choose between pin control and I²C control mode. In pin control mode, the PORT input pin determines the port setting in which host, device or dual-role port can be selected. In host mode, the system can monitor ID pin to know the connector status while default current mode is set. Systems running in device mode can monitor system VBUS for connector status as well as OUT1 and OUT2 pins for host's charging profile capability. Enabling I²C control mode allows higher flexibility for port control and communications through registers read/write in PI5USB30216D. There is also flexibility to support Default, 1.5A and 3A current modes. An interrupt signal for indicating changes with the I²C registers is sent to the master to notify the system any change in the Type-C connector while in parallel the system can still monitor ID pin.

Block Diagram

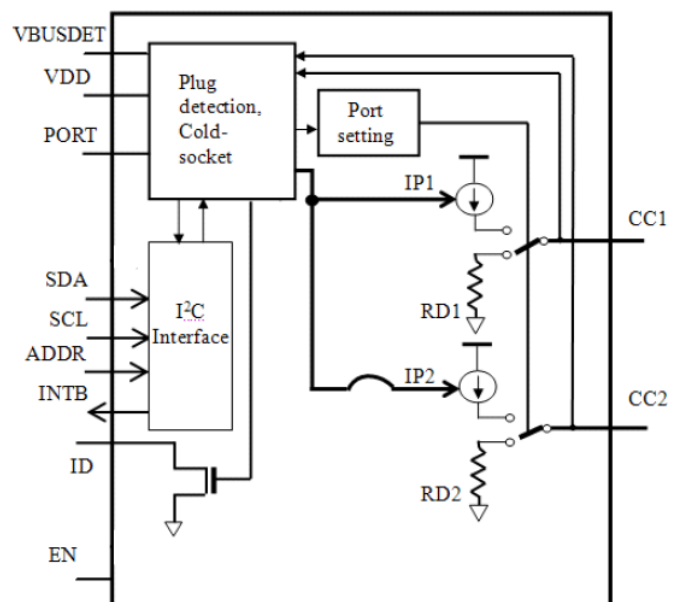

Figure 2. PI5USB30216D Block diagram

Plug-in Detector for Type-C Connector
Pin Descriptions

Pin Number	Pin Name	I/O	Description
1	CC1	I/O	Type-C Configuration channel signal
2	CC2	I/O	Type-C Configuration channel signal
3	PORT	I	Tri-level input pin to indicate port mode in pin control mode (see functional description): PORT is floating – Dual role (DRP with Try.SNK in Pin Control Mode); PORT=VDD – Host (SRC); PORT=GND – Device (SNK)
4	VBUSDET	I	4V to 28V VBUS input voltage. VBUS detection determines Device attachment. One 910kΩ external resistor required between system VBUS and VBUSDET pin
5	ADDR	I	Tri-level input pin to indicate I ² C address or-pin control mode: ADDR is floating – Pin control mode; ADDR=VDD – I ² C enabled with ADDR bit 6 equal to 1; ADDR=GND – I ² C enabled with ADDR bit 6 equal to 0
6	INTB / OUT3	O	Open drain output. In I ² C control mode, this is an active LOW interrupt signal for indicating changes in I ² C registers. Dual function as audio adapter accessory detection in pin control mode: OUT3=Hi-Z – Not detected OUT3=Low – Audio-adapter accessory detected
7	SDA / OUT1	I/O	I ² C communication data signal. Dual function as open drain Type-C Current Mode Detect 1 in pin control mode when port is a device: <u>OUT2 OUT1 Current Mode</u> Hi-Z Hi-Z Default Hi-Z Low Medium Low Low High
8	SCL / OUT2	I/O	I ² C communication clock signal. Dual function as open drain Type-C Current Mode Detect 2 in pin control mode when port is a device: <u>OUT2 OUT1 Current Mode</u> Hi-Z Hi-Z Default Hi-Z Low Medium Low Low High
9	ID	O	Open drain output. Asserted low when CC pin detected device attachment when port is a Host (or dual-role acting as Host), otherwise ID is hi-z.
10	GND	Ground	Ground
11	EN	I	Active-high enable input pin (with internal weak pull down) EN=GND – Disabled/Low Power State EN=VDD – Enabled/Active State
12	VDD	Power	Positive supply voltage from VBAT

Application Circuit

DRP in I2C Mode

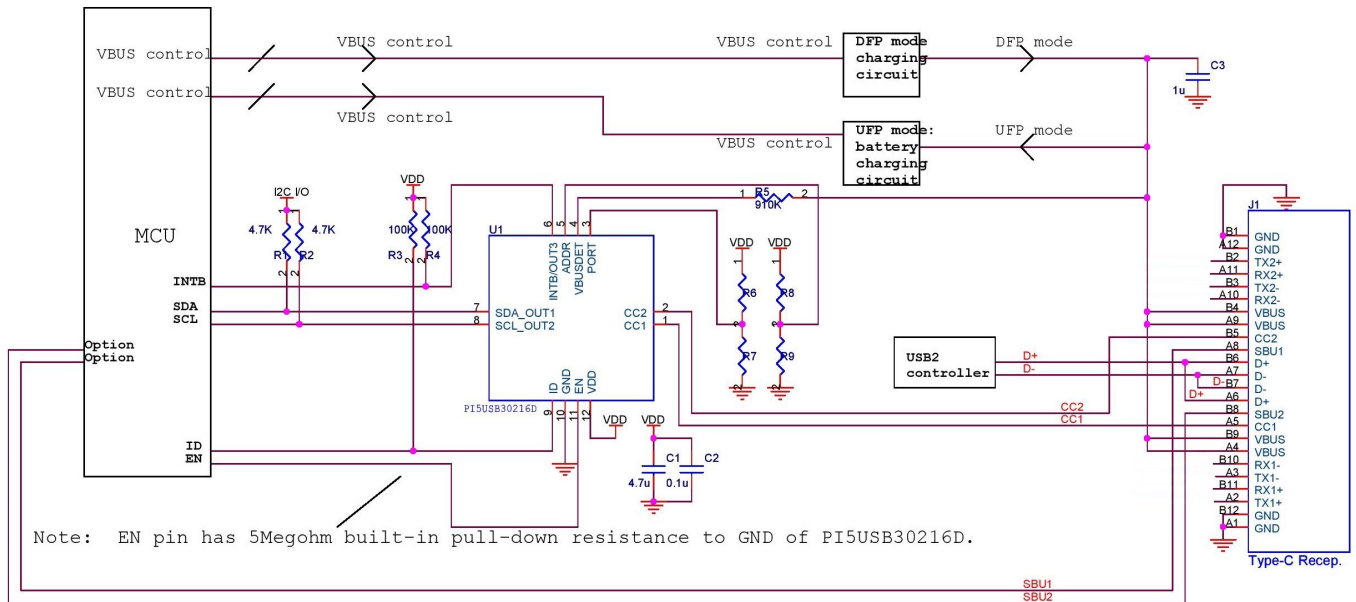

Type-C port mode	R6	R7
UFP/Sink/Device	NC	4.7K
DFP/Source/Host	4.7K	NC
DRP	NC	NC

Control mode	R8	R9
I2C mode address: 7-bit addressing: 0x1D or 8-bit write address: 0x3A 8-bit read address: 0x3B	NC	4.7K
I2C mode address: 7-bit addressing: 0x3D or 8-bit write address: 0x7A 8-bit read address: 0x7B	4.7K	NC
Pin Control Mode	NC	NC

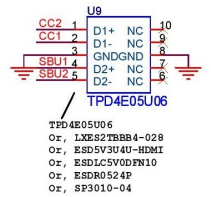

Maximum Ratings

Storage Temperature.....	-65°C to +150°C
Supply Voltage from Battery/Baseband	-0.5V to +6.0V
ID Pin Sink current	10mA
ESD: HBM all pins.....	2000V

Note:

Stresses greater than those listed under MAXIMUM RATINGS may cause permanent damage to the device. This is a stress rating only and functional operation of the device at these or any other conditions above those indicated in the operational sections of this specification is not implied. Exposure to absolute maximum rating conditions for extended periods may affect reliability.

Recommended operation conditions

Symbol	Parameter	Min.	Max.	Units
V _{DD}	Battery Supply Voltage	2.7	5.5	V
V _{BUS}	System VBUS Voltage	4	28	V
V _{BAT TH}	Battery Supply Under-Voltage Lockout Threshold	2.2	2.6	V
V _{IH}	High level input voltage (EN, SCL, SDA)	1.05	-	V
V _{IL}	Low level input voltage (EN, SCL, SDA)	-	0.4	V
V _{3IH}	High level input voltage (ADDR, PORT)	V _{DD} -0.4	-	V
V _{3IL}	Low level input voltage (ADDR, PORT)	-	0.4	V
V _{VBUSDET}	VBUSDET input voltage ⁽¹⁾	-	4.5V	V
V _{TYPEC CC}	CC1, CC2 input voltage ⁽²⁾	-	V _{DD} +0.5	V
V _{TYPEC VCONN}	CC1, CC2 input voltage when it is used for VCONN	-	5.5	V
T _A	Operating Temperature	-40	85	°C

(1) V_{VBUSDET} pin is internally clamp to ~5.5V.

(2) CC1, CC2 pins are internally clamp to ~V_{DD}+1.0V except when the pin is used for VCONN during attached.SRC state

DC Electrical Characteristics

Min and Max apply for T_A between -40°C to 85°C and T_J up to +125°C (unless otherwise noted).

Typical values are referenced to V_{DD}=3.6V, T_A=+25°C

Symbol	Parameter	Test Conditions	Min.	Typ.	Max.	Units
CC1/CC2 Configuration(Device mode, SNK)						
R _d	Device mode pull-down resistor		4.6	5.1	5.6	kΩ
V _{IH3_SNK}	High current mode entry threshold		1.16	1.23	1.31	V
V _{IH2_SNK}	Medium current mode entry threshold		0.61	0.66	0.70	V
V _{IH1_SNK}	Default current mode entry threshold		0.15	0.2	0.25	V
CC1/CC2 Configuration(Host mode, SRC)						
I _p	Host mode pull up current source	Default current mode	64	80	96	μA
		Medium current mode (1.5A)	166	180	194	
		High current mode (3A)	304	330	356	
VBUS Detection						
V _{VBUS}	VBUS detection threshold	R _{VBUS} =910kohm	2.51	3.01	4.01	V
R _{VBUS}	External resistor between VBUS and VBUSDET pin		865	910	955	kΩ
Host Interface Pins (INTB, ID, OUT1, OUT2, OUT3)						
V _{OL}	Output Low Voltage at 1.6 mA Sink current(Open-Drain)		0	-	0.4	V
I _{OFF}	Off-state leakage current	V _{INTB, ID/ID/OUT1/OUT2/OUT3}	-	-	1	μA
Input Control Pins (EN, ADDR, PORT, SCL, SDA)						
I _{IH}	High-level input current		-5	-	5	μA
I _{IL}	Low-level input current		-5	-	5	μA
R _{IEN}	Internal pull-down resistance for EN		2	5	10	MΩ
Current Consumption						
I _{DD}	Operating current, Device mode	SNK connects to SRC	-	35	65	μA
	Operating current, Host mode	SRC connects to SNK Default current mode	-	135	190	μA
I _{DISABLE}	Chip is disabled	EN=GND	-	-	5	μA
I _{DEV STBY}	Device mode standby current	V _{DD} =3.6V, Floating CC1 and CC2	-	35	65	μA
I _{DUAL STBY}	Dual-Role mode standby current	V _{DD} =3.6V, Floating CC1 and CC2	-	45	75	μA
I _{HOST STBY}	Host mode standby current	V _{DD} =3.6V, Floating CC1 and CC2	-	55	85	μA

Detailed Description using I2C Control

ADDR

ADDR is a tri-level input pin to indicate I2C or pin control (or GPIO) mode. When ADDR pin is floating, the part is set to pin control mode. When ADDR is set to VDD or GND, I2C mode is enabled, and bit 6 of I2C address is equal to 1 or 0 according to ADDR set to VDD or GND (see Table 2: I2C Slave Address).

Configuration

The PI5USB30216D requires minimal configuration for proper detection and reporting. Write register 0x02 (Control Register) to configure different charging profiles and port settings.

Processor Communication

Typical communication steps between the processor and the PI5USB30216D during plug detection are:

1. INTB asserted LOW, indicating changes in register 0x03 (Interrupt Register) or register 0x04 (CC Status Register).
2. Processor reads Interrupt registers to determine which event occurred. Interrupt Register (0x03) indicates if an attach or detach event was detected. All interrupt flags in Interrupt Register (0x03) will be cleared after the I²C read action. INTB will become hi-z again after the clearance of interrupt flags.
3. Processor reads CC Status Register (0x04) to determine plugin details and charging profile. Processor can configure the power and USB channels according to information in CC Status Register (0x04).

Interrupts

The baseband processor recognizes interrupt signals by observing the INTB signal, which is active LOW. Interrupts are masked upon bit 0 of Control Register 0x02 (Interrupt Mask Bit). After the Interrupt Mask Bit is cleared by the baseband processor, the INTB pin is hi-z in preparation for a future interrupt. When an interruptible event occurs, INTB pin transits to LOW and returns hi-z when the processor reads the Interrupt Register (0x03). Subsequent to the initial power up or reset; if the processor writes a “1” to Interrupt Mask Bit (bit 0 of Control Register 0x02) when the system is already powered up, INTB pin stays hi-z and ignores all interrupts until the interrupt mask bit is cleared.

Besides monitoring the I²C registers, the system can also monitor ID pin and VBUS for connector status. If the port is configured as a device (or dual-role acting as device), VBUS will go to 5V when host attachment is detected. If the port is configured as a host (or dual-role acting as host), ID pin will pull low when device attachment is detected, and system should assert VBUS.

Port Setting (Host/Device/Dual-Role)

When power is applied to VDD, an internal Power-On Reset (POR) holds the PI5USB30216D in a reset condition until VDD has reached 2.6V. At that point, the reset condition is released and the PI5USB30216D registers and I²C-bus state machine will initialize to their default states. After power up, the port setting can be changed by I2C writes to [2:1] of Control Register (0x02). Thereafter, VDD must be lowered below 1.0V to reset the device (both registers and I²C-bus state machine).

PI5USB30216D connects current sources to CC1 and CC2 when operating in host mode. It will also set the current level according to the charging current setting. In device mode, PI5USB30216D will connect two integrated resistor Rd1 and Rd2 to CC1 and CC2 respectively.

Dual-Role & Dual-Role 2 modes enables CC1 and CC2 toggle between host mode and device mode alternatively. The toggling will stop after connection is made and role negotiated. Dual-Role mode has similar chances to connect as SRC or SNK. Dual-Role 2 with Try.SNK supported has higher chance to connect as SNK and has a longer duty cycle ~65% in device mode. Dual-Role 2 with Try.SRC supported has higher chance to connect as SRC and has a longer duty cycle ~65% in host mode.

Current Mode Setting and Detection

PI5USB30216D can be configured as different current modes per CC1/CC2 setting. Host mode (or dual role acting as Host) allows the system to configure between High Current Mode (3A), Medium Current Mode (1.5A) and Default Current Mode. Different current modes can be set by writing Control Register (0x02). When in Device mode (or dual role acting as device), CC1/CC2 pins allow the system to detect the host charging capability. The charging capability is reported in CC Status Register (0x04) which can help the system to configure the charging current accordingly.

ID

When PI5USB30216D is configured as host mode (or dual role acting as host), ID pin will be pulled low when a device is attached to the type-C connector. The ID pin will work as an interrupt signal to acknowledge system when there is device attachment. It should be noted the ID pin will not be driven low when an audio or debug accessory is detected, and ID pin will always stay Hi-Z when port is in device mode.

Audio Adapter Accessory and Debug Accessory Mode

PI5USB30216D can detect audio adapter accessory or debug accessory attachment as per CC1/CC2 setting. This is reported in CC Status Register (0x04) to help system to configure Audio Adapter Accessory Mode or Debug Accessory Mode accordingly.

VBUS Detection

PI5USB30216D detects VBUS to determine the attached state when port is a device. A 910kohm +/- 5% is required to connect VBUS of the connector to VBUSDET input pin to protect the IC from the possible high voltage of VBUS during alternative mode.

EN

EN is an active high enable input pin. When EN pin is low, part is in disable and low power state. All outputs, with the exception of CC1, CC2, SCL, SDA & INTB are in High-Z state. CC1 and CC2 pins are pulled low with resistors Rd in disable state. I²C port will also be reset during disable state. SCL & SDA are still functional when the part is disable and ADDR is not floating. I2C port will also reset during every transition (rising or falling edge) of EN. Connection State will also be reset and forced to be Unattached.SNK state. Interrupt will be set low and Register 03H/04H (Interrupt/CC status) will be updated to indicate the change of state. However, disable has no effect on the value of Register 02H (Control).

When EN pin is high, part is enabled. The connection state will activate and detection will restart.

Dead Battery Startup

PI5USB30216D ensures dead battery charging when VDD=0V. Both CC1 and CC2 will be pulled down when VDD=0V. Such configuration helps other host port detect the dead battery port as a device mode port and enable charging through VBUS.

Pin Control Functional Description

Type-C Connector Port Setting (PORT)

PI5USB30216D can be configured as different ports by changing PORT pin voltage level.

Table 1A. Port Setting

Port setting	PORT
Device (SNK)	GND
Dual-role port (DRP) with Try.SNK	No Connection
Host (SRC)	VDD

Type-C Connector Current Mode Detection (OUT1, OUT2)

PI5USB30216D can detect different host current modes and other accessories per CC1/CC2 setting. When PI5USB30216D operates in device mode (or dual role mode acting as device), it detects CC1/CC2 status to determine host charging current modes and reports to the system using OUT1 and OUT2 pins. OUT1 and OUT2 will always stay hi-z unless medium or high current mode is detected.

Table 1B. Current Mode Detection

	OUT2	OUT1
Default current mode	Hi-Z	Hi-Z
Medium current mode (1.5A)	Hi-Z	Low
High current mode (3A)	Low	Low

Type-C Connector Current Mode Setting in Host Mode

When PI5USB30216D is configured as a host, it can only be set to Default Current Mode (current source $I_p=80\mu A$). I2C control is required to set current mode to 1.5A or 3A.

Audio Adapter Accessory Detection (OUT3)

PI5USB30216D—detects audio adapter accessory attachment as per CC1/CC2 setting. This is reported by the OUT3 pin. OUT3 will be pulled low when an audio adapter accessory attachment is detected. Otherwise, OUT3 is hi-z.

Table 1C. Audio Adapter Accessory Detection

Audio Adapter Accessory	OUT3
Detected	Low
Not Detected	Hi-Z

ADDR, ID, EN, and Dead Battery Startup

Functionality of the ADDR, ID, and EN pins are the same for pin control or I2C control modes. Dead battery startup operation is also the same for pin control and I2C control modes. Please refer to previous section for detail description.

I²C AC Electrical Characteristics

Symbol	Parameter	Fast Mode (400kHz)		Units
		Min.	Max.	
f _{SCL}	SCL Clock Frequency	0	400	kHz
t _{HDSTA}	Hold Time (Repeated) START Condition	0.6	-	μs
t _{LOW}	LOW Period of SCL Clock	1.3	-	μs
t _{HIGH}	HIGH Period of SCL Clock	0.6	-	μs
t _{SETSTA}	Set-up Time for Repeated START Condition	0.6	-	μs
t _{HDDAT}	Data Hold Time	0	0.9	μs
t _{SETDAT}	Data Set-up Time	250	-	ns
t _r	Rise Time of SDA and SCL Signals	-	300	ns
t _f	Fall Time of SDA and SCL Signals	-	300	
t _{SETSTO}	Set-up Time for STOP Condition	0.6	-	μs
t _{BUF}	Bus-Free Time between STOP and START Conditions	1.3	-	μs
t _{SP}	Pulse Width of Spikes that Must Be Suppressed by the Input Filter	0	50	ns

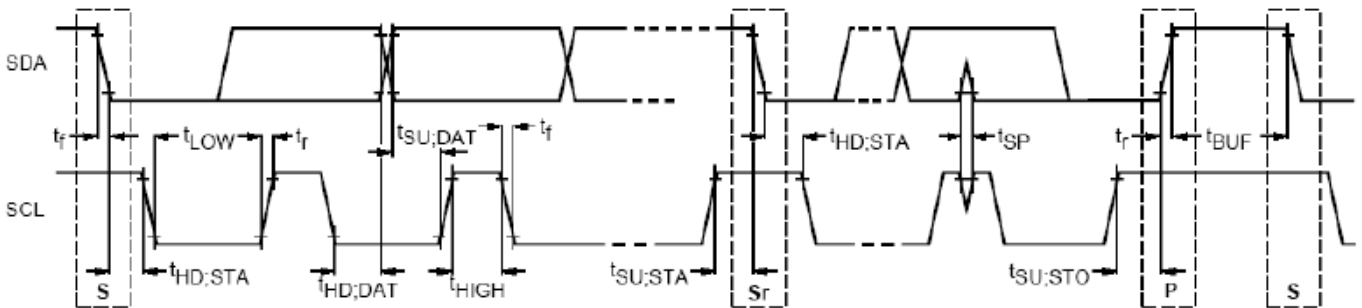

Figure 3. Definition of Timing for Full-Speed Mode Devices on the I²C Bus

Table 2. I²C Slave Address

Name	Size (Bits)	Bit 7	Bit 6	Bit 5	Bit 4	Bit 3	Bit 2	Bit 1	Bit 0
Slave Address(ADDR=1)	8	0	1	1	1	1	0	1	R/W
Slave Address(ADDR=0)		0	0	1	1	1	0	1	R/W

I²C Data Transfer

1. Read Sequence

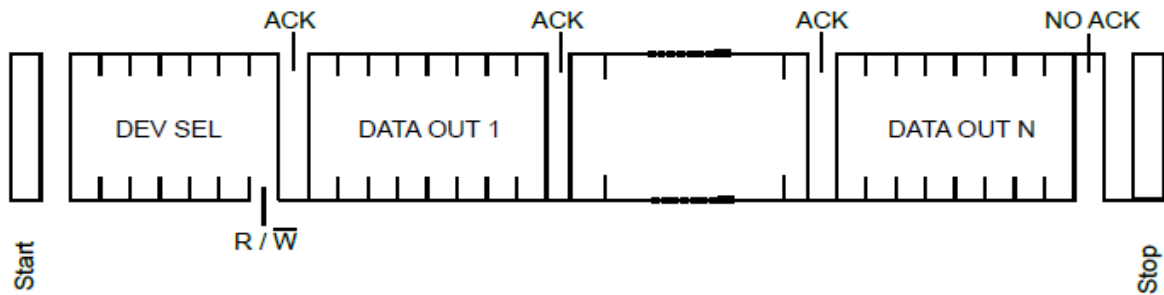

2. Write Sequence

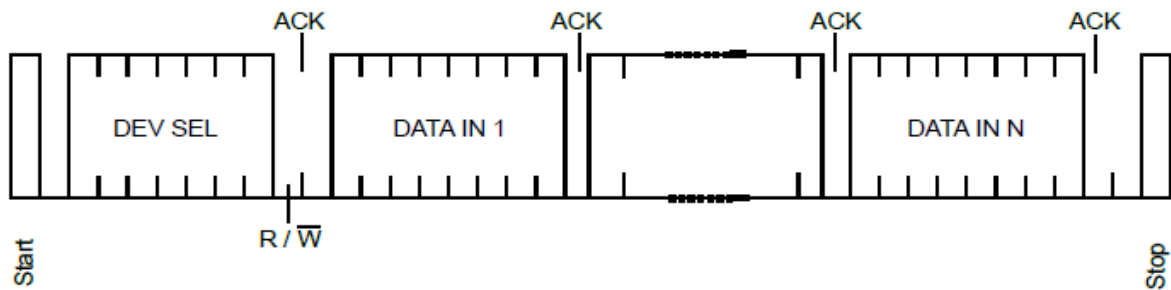

Note:

1. PI5USB30216D does not have offset byte. All registers must be read or written sequentially from 0x00. For example, in order to read address 0x04, PI5USB30216D I²C registers must be read sequentially from 0x01, 0x02, 0x03 to 0x04. In order to write address 0x02, it must be written sequentially from 0x01 to 0x02.

Table 3. I²C Register

Address	Name	Description	Default Value	Type
0x01	Device ID	<p>Bits [7:5] = Chip ID</p> <p>01h = PI5USB30216D</p> <p>Bits [4:3] = Version ID</p> <p>00h = Product version</p> <p>Bits [2:0] = Vendor ID(Pericom)</p> <p>00h = Pericom</p>	20h	R
0x02	Control	<p>Bit 7 = Powersaving</p> <p>0 = Enable/Active state 1 = Disable and low power state In Disable and low power state, all outputs of PI5USB30216D, with the exception of CC1 and CC2 pins, are in High-Z State. CC1 and CC2 pins are pulled low with resistor Rd.</p> <p>Bits [6] = Dual role 2 Try.SRC or Try.SNK setting</p> <p>0 = Enable Try.SRC supported 1 = Enable Try.SNK supported</p> <p>Bits [5] = Accessory Detection in Device Mode</p> <p>0 = Disable 1 = Enable</p> <p>Bits [4:3] = Charging current mode System can set the charging current mode when port is a host or dual role acting as host. These bits are ignored when port is a device or dual role acting as device.</p> <p>00 = Default current mode 01 = Medium current mode (1.5A) 10 = High current mode (3A)</p> <p>Bits [2:1] = 00h (POR value) System can set the role of the port.</p> <p>00 = Device (SNK) 01 = Host (SRC) 10 = Dual Role (DRP) 11 = Dual Role 2 (DRP) where Try.SRC or Try.SNK is supported</p> <p>Bit 0 = Interrupt Mask INTB pin is used to acknowledge system if there is any interrupt events triggered. When this bit is set to 0, INTB pin is pulled low when an interrupt event occur. When this bit is set to 1, INTB pin ignores all interrupt and remain High-Z.</p> <p>0 = Do not mask interrupt 1 = Mask interrupt</p>	00h	R/W
0x03	Interrupt	<p>Bits [7:2] = Reserved. Read all 0's.</p> <p>Bit 1 = Detach event When this bit is set to 1, it indicates the unplug action. The port changes from attached state (Attached.SNK, Attached.SRC, AudioAccessory or DebugAccessory state) to unattached state.</p> <p>Bit 0 = Attach event When this bit is set to 1, it indicates the plug action. The port changes from unattached state to attached state.</p>	00h	Clearable read only. Bits[1:0] are cleared when Byte 3 is read.

Address	Name	Description	Default Value	Type
0x04	CC status	<p>Bit 7 = VBUS detection This bit reports VBUS status when PI5USB30216D is in device mode, dual role mode acting as device or accessory mode.</p> <p>0 = VBUS not detected 1 = VBUS detected</p> <p>Bits [6:5] = Charging current detection These bits report the detected host charging current status when port is a device or dual role acting as device.</p> <p>00 = Standby 01 = Default current mode 10 = Medium current mode (1.5A) 11 = High current mode (3A)</p> <p>Bits [4:2] = Attached port status</p> <p>000 = Standby 001 = Device 010 = Host 011 = Audio Adapter Accessory 100 = Debug Accessory 101 = Device with Active Cable</p> <p>Bits [1:0] = Plug polarity</p> <p>00 = Standby 01 = CC1 makes connection 10 = CC2 makes connection 11 = Undetermined (e.g. AudioAccessory, DebugAccessory or other undetermined connections)</p>	00h	R

Table 3. I2C Register Table

Address	Register	Type	Reset Value	Bit 7	Bit 6	Bit 5	Bit 4	Bit 3	Bit 2	Bit 1	Bit 0	
01H	Device ID	Read	00100000	Chip ID (PI5USB30216D): 001			Version ID : 00		Vendor ID (Pericom): 000			
02H	Control	Read / Write	00000000	Powersaving	Dual Role 2	Accessory Detection in Device Mode	Charging Current mode (Port is a Host)		Port setting (see below)		Interrupt Mask	
				0: No Powersaving 1: Powersaving	0: Try.SRC supported 1: Try.SNK supported	0: Disable 1: Enable	00: Default 01: Medium 10: High	00: Device 01: Host 10: Dual Role 11: Dual Role 2	0: Does not Mask Interrupts 1: Mask Interrupts			
03H	Interrupt	Read / Clear	00000000	reserved						Detach Event	Attach Event	
										0: No Interrupt		
										1: Change from attached to detached	1: Change from detached to attached	
04H	CC status	Read	00000000	VBUS detection (Port is a Device or in accessory mode)	Charging current detection (Port is a Device)		Attached Port Status		Plug polarity			
				0: Vbus not detected 1: Vbus detected	00: Standby 01: Default 10: Medium 11: High	000: Standby 001: Device 010: Host 011: Audio 100: Debug Accessory 101: Device with Active cable	00: Standby 01: CC1 connected 10: CC2 connected 11: undetermined					

In I2C mode, PI5USB30216D will initialize to device mode when powered up, Bit 1 and Bit 2 of the register 02H is 00 whenever the Port is GND, VDD or floating.

Connection State Diagram: SRC

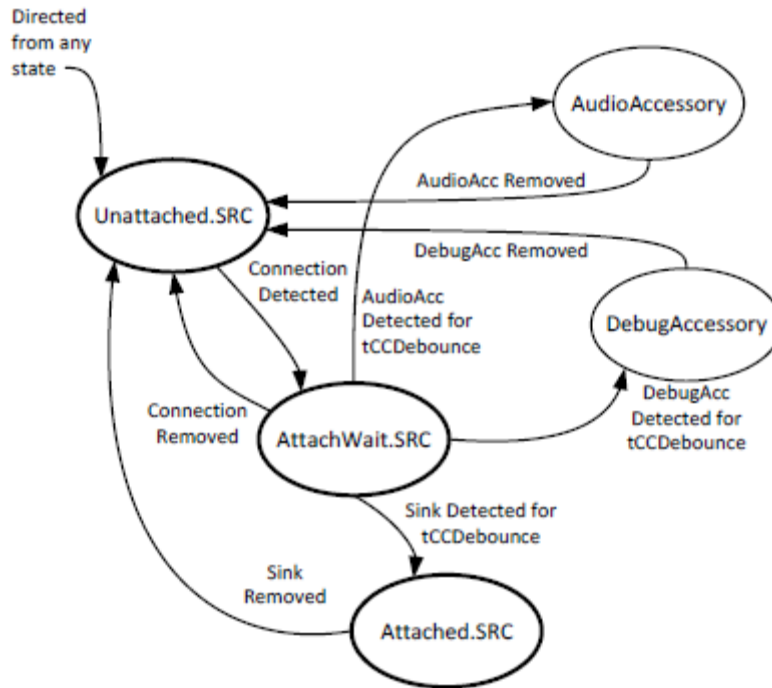

Connection State Diagram: SNK (Accessory Detection is disable)

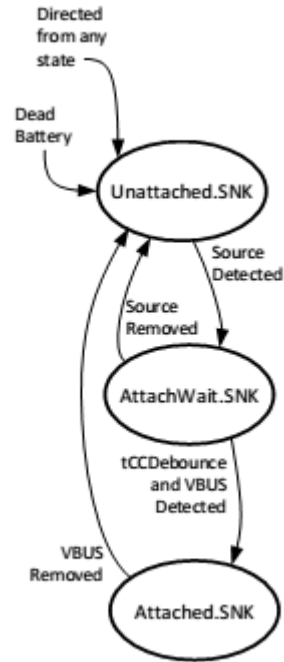

Connection State Diagram: SNK (Accessory Detection is enable)

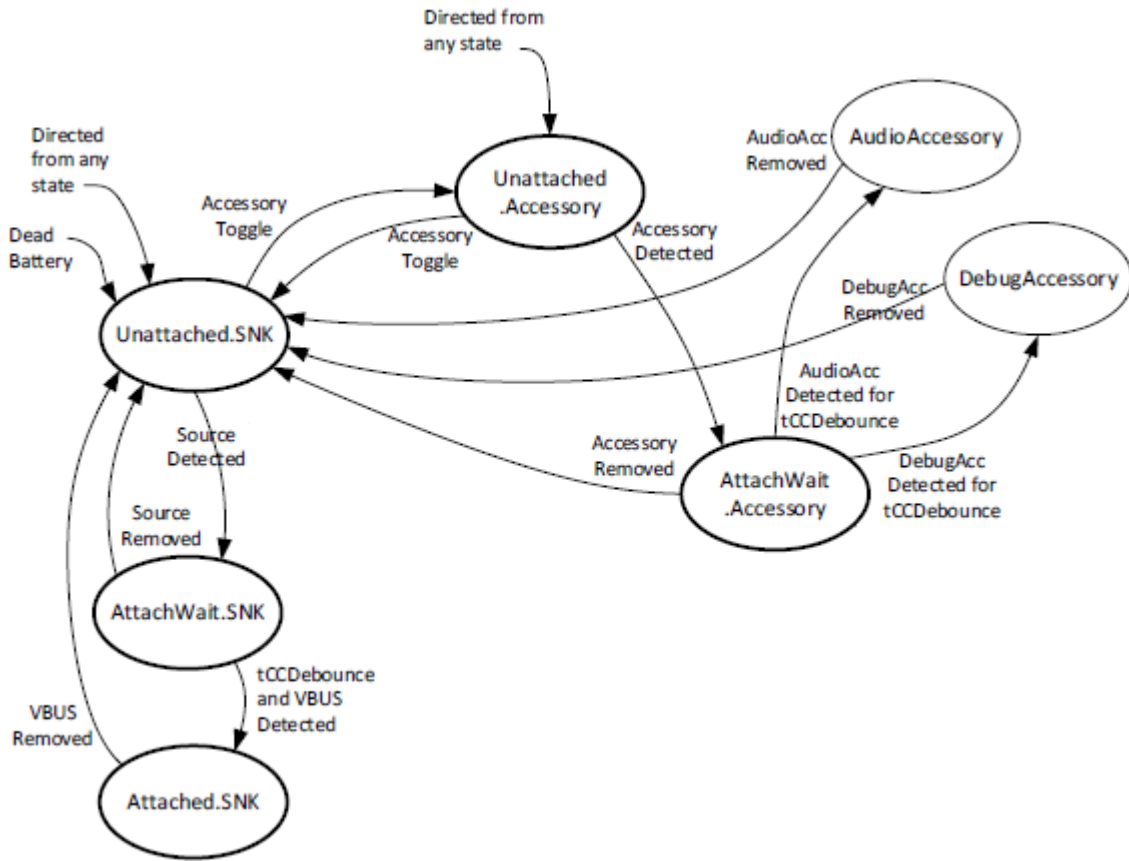

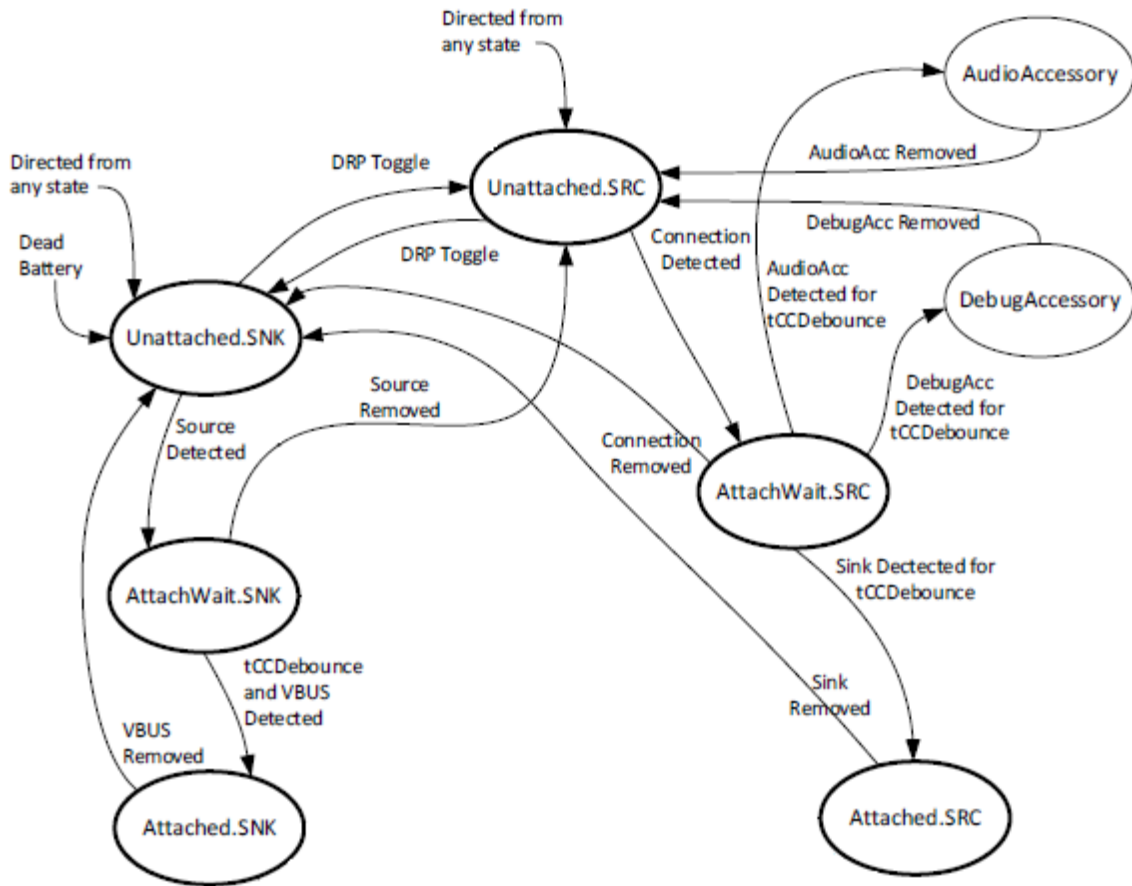
Connection State Diagram: DRP

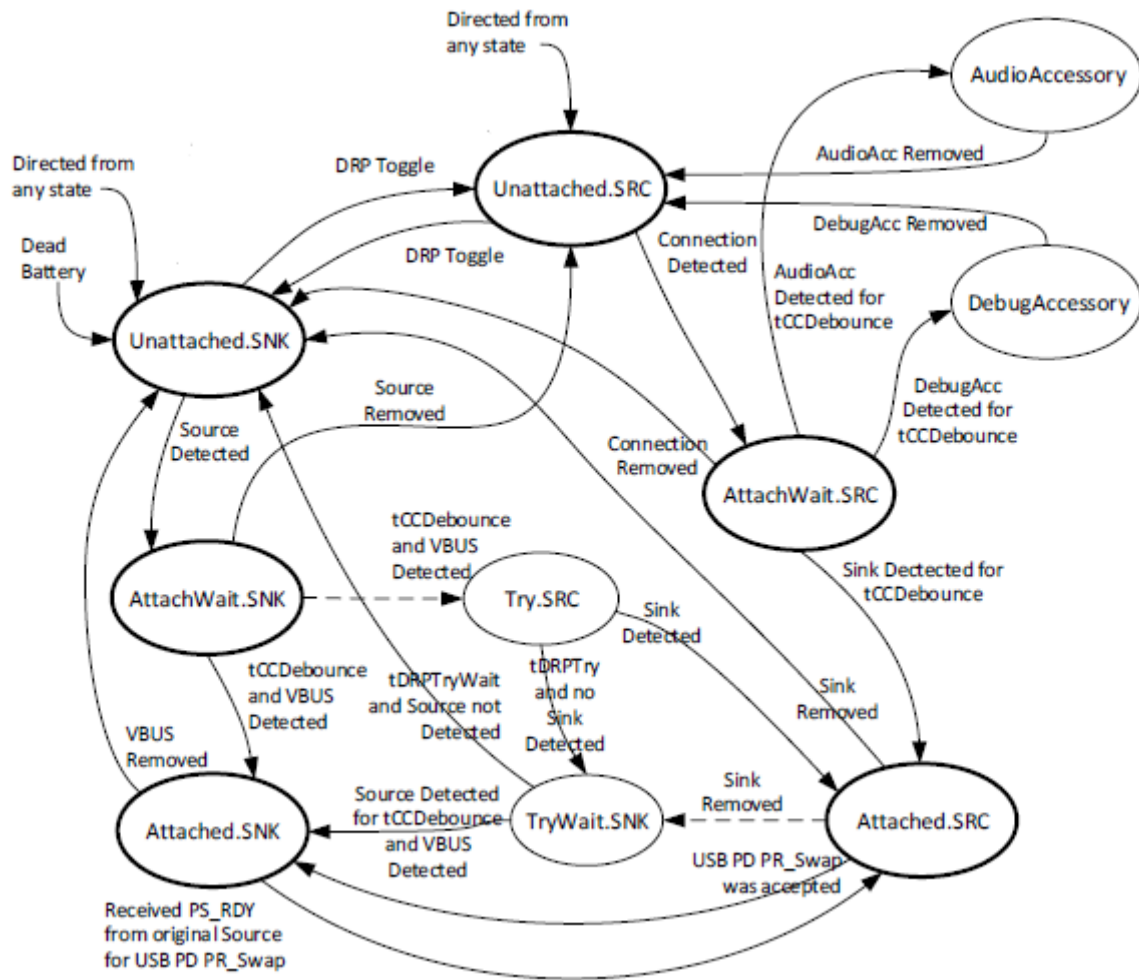
Connection State Diagram: DRP with Try.SRC Supported

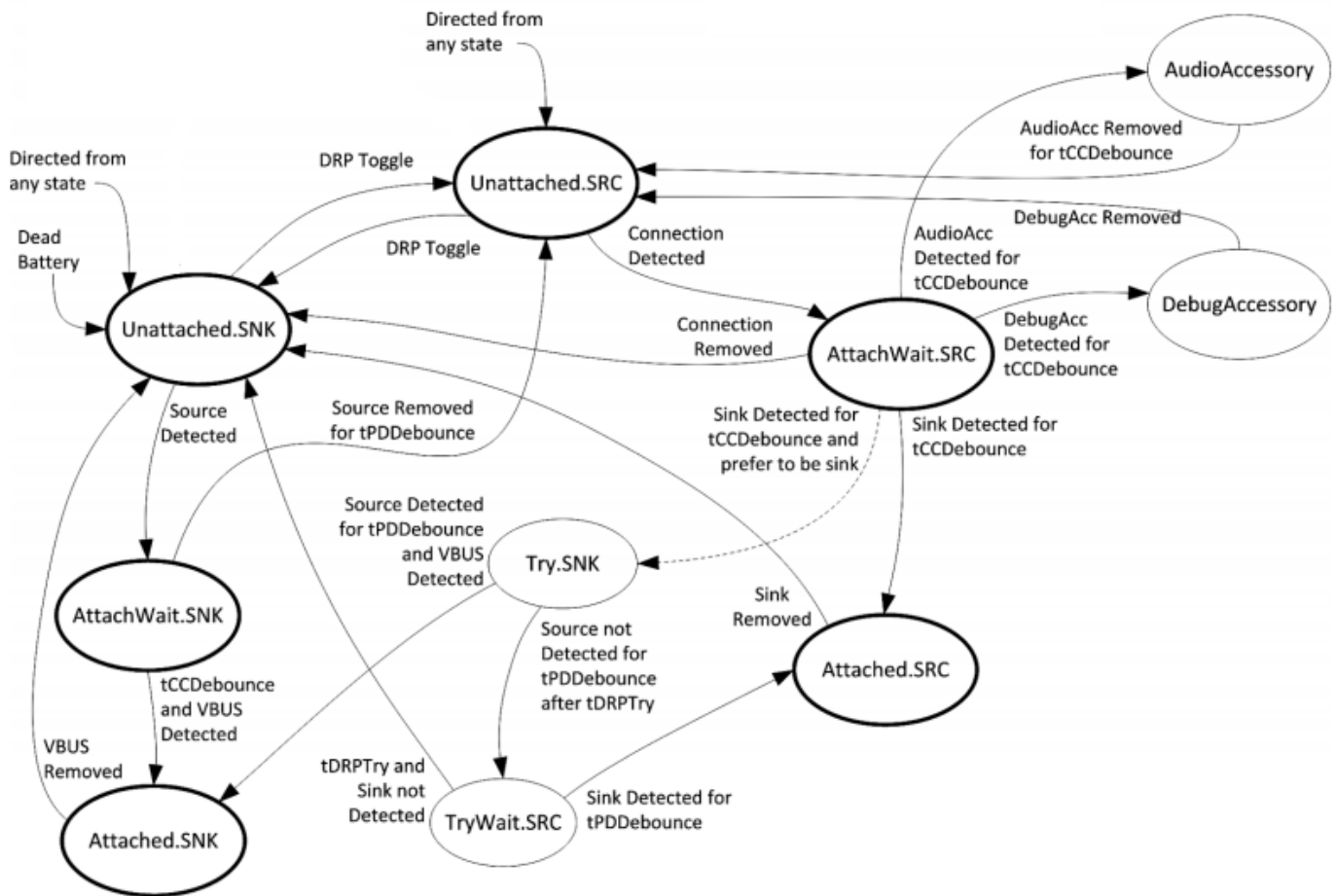
Connection State Diagram: DRP with Try.SNK Supported

Mechanical Information

STQFN 1.6 X 1.6 -12 Contact (To Be Provided)

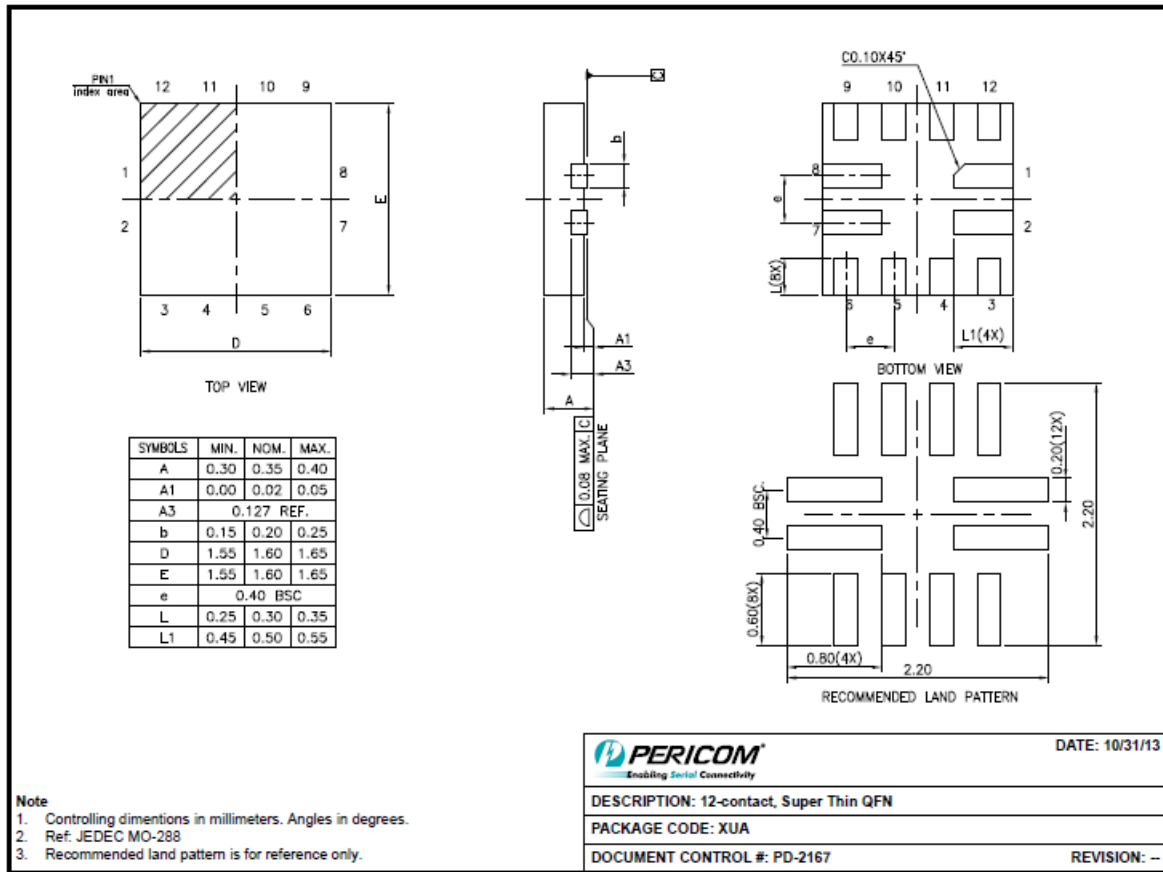

Ordering Information

Ordering Number	Package Code	Package Description
PI5USB30216DXUAEX	XUA	12-Contact, Super Thin (QFN), Tape & Reel

Note:

1. Thermal characteristics can be found on the company web site at www.pericom.com/packaging/
2. E = Pb-free and Green
3. X suffix = Tape/Reel

Pericom Semiconductor Corporation • 1-800-435-2336 • www.pericom.com

Pericom reserves the right to make changes to its products or specifications at any time, without notice, in order to improve design or performance and to supply the best possible product. Pericom does not assume any responsibility for use of any circuitry described other than the circuitry embodied in Pericom product. The company makes no representations that circuitry described herein is free from patent infringement or other rights of Pericom.

Mouser Electronics

Authorized Distributor

Click to View Pricing, Inventory, Delivery & Lifecycle Information:

[Diodes Incorporated:](#)

[PI5USB30216DXUAEX](#)