

Automotive fully integrated H-bridge motor driver

Features

Type	$R_{DS(on)}$	I_{out}	V_{CCmax}
VNH5050A-E	50 mΩ max (per leg)	30 A	41 V

- Output current: 30 A
- 3 V CMOS compatible inputs
- Undervoltage and overvoltage shutdown
- Overvoltage clamp
- Thermal shutdown
- Cross-conduction protection
- Current and power limitation
- Very low standby power consumption
- PWM operation up to 20 KHz
- Protection against loss of ground and loss of V_{CC}
- Current sense output proportional to motor current
- Output protected against short to ground and short to V_{CC}
- Package: ECOPACK®

Description

The VNH5050A-E is a full bridge motor driver intended for a wide range of automotive applications. The device incorporates a dual monolithic high-side driver and two low-side switches. All switches are designed using STMicroelectronics® well known and proven

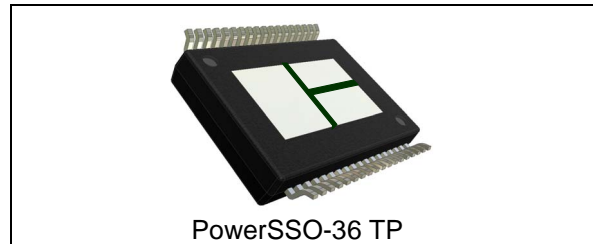

proprietary VIPower® M0 technology that allows to efficiently integrate on the same die a true Power MOSFET with an intelligent signal/protection circuitry. The three dies are assembled in a PowerSSO-36 TP package on electrically isolated lead frames. This package, specifically designed for the harsh automotive environment offers improved thermal performance thanks to exposed die pads. Moreover, its fully symmetrical mechanical design allows superior manufacturability at board level. The input signals IN_A and IN_B can directly interface to the microcontroller to select the motor direction and the brake condition. The $DIAG_A/EN_A$ or $DIAG_B/EN_B$, when connected to an external pull-up resistor, enables one leg of the bridge. Each $DIAG_A/EN_A$ provides a digital diagnostic feedback signal as well. The normal operating condition is explained in the truth table. The CS pin allows monitoring the motor current by delivering a current proportional to its value when CS_DIS pin is driven low or left open. When CS_DIS is driven high, CS pin is in high impedance condition. The PWM, up to 20 KHz, allows to control the speed of the motor in all possible conditions. In all cases, a low level state on the PWM pin turns off both the LS_A and LS_B switches.

Table 1. Device summary

Package	Order codes	
	Tube	Tape and reel
PowerSSO-36 TP	VNH5050A-E	VNH5050ATR-E

Contents

- 1 Block diagram and pin description 5**

- 2 Electrical specifications 8**
 - 2.1 Absolute maximum ratings 8
 - 2.2 Thermal data 9
 - 2.3 Electrical characteristics 10
 - 2.4 Waveforms 19

- 3 Application information 21**
 - 3.1 Reverse battery protection 22

- 4 Package and PCB thermal data 24**
 - 4.1 PowerSSO-36 thermal data 24
 - 4.1.1 Thermal calculation in clockwise and anti-clockwise operation in steady-state mode 25
 - 4.1.2 Thermal resistances definition (values according to the PCB heatsink area) 25
 - 4.1.3 Thermal calculation in transient mode 26

- 5 Package and packing information 29**
 - 5.1 ECOPACK® packages 29
 - 5.2 PowerSSO-36 TP package information 29
 - 5.3 PowerSSO-36 TP packing information 31

- 6 Revision history 32**



List of tables

Table 1.	Device summary	1
Table 2.	Block description	5
Table 3.	Suggested connections for unused and not connected pins	6
Table 4.	Pin definitions and functions	6
Table 5.	Pin functions description	7
Table 6.	Absolute maximum ratings	8
Table 7.	Thermal data	9
Table 8.	Power section	10
Table 9.	Logic inputs (IN _A , IN _B , EN _A , EN _B , PWM, CS_DIS)	11
Table 10.	Switching (V _{CC} = 13 V, R _{LOAD} = 1.5 Ω)	11
Table 11.	Protections and diagnostics	11
Table 12.	Current sense (9 V < V _{CC} < 18 V)	12
Table 13.	Truth table in normal operating conditions	17
Table 14.	Truth table in fault conditions (detected on OUTA)	17
Table 15.	Electrical transient requirements (part 1/3)	18
Table 16.	Electrical transient requirements (part 2/3)	18
Table 17.	Electrical transient requirements (part 3/3)	18
Table 18.	Thermal calculation in clockwise and anti-clockwise operation in steady-state mode	25
Table 19.	Thermal parameters	28
Table 20.	PowerSSO-36 TP mechanical data	30
Table 21.	Document revision history	32

List of figures

Figure 1.	Block diagram	5
Figure 2.	Configuration diagram (top view)	6
Figure 3.	Current and voltage conventions	8
Figure 4.	Definition of the delay times measurement	14
Figure 5.	Definition of the low-side switching times	15
Figure 6.	Definition of the high-side switching times	15
Figure 7.	Definition of dynamic cross conduction current during a PWM operation.	16
Figure 8.	Definition of delay response time of sense current.	16
Figure 9.	Waveforms in full-bridge operation	19
Figure 10.	Waveforms in full-bridge operation (continued)	20
Figure 11.	Typical application circuit for DC to 20 kHz PWM operation short circuit protection	21
Figure 12.	Behavior in fault condition (how a fault can be cleared)	22
Figure 13.	Half-bridge configuration.	23
Figure 14.	Multi-motors configuration	23
Figure 15.	PowerSSO-36™ PC board.	24
Figure 16.	Chipset configuration	25
Figure 17.	Auto and mutual $R_{thj-amb}$ vs PCB copper area in open box free air condition	25
Figure 18.	Detailed chipset configuration.	26
Figure 19.	PowerSSO-36 HSD thermal impedance junction ambient single pulse	27
Figure 20.	PowerSSO-36 LSD thermal impedance junction ambient single pulse	27
Figure 21.	Thermal fitting model of an H-bridge in PowerSSO-36.	28
Figure 22.	PowerSSO-36 TP package dimensions	29
Figure 23.	PowerSSO-36 TP tube shipment (no suffix).	31
Figure 24.	PowerSSO-36 TP tape and reel shipment (suffix "TR")	31

1 Block diagram and pin description

Figure 1. Block diagram

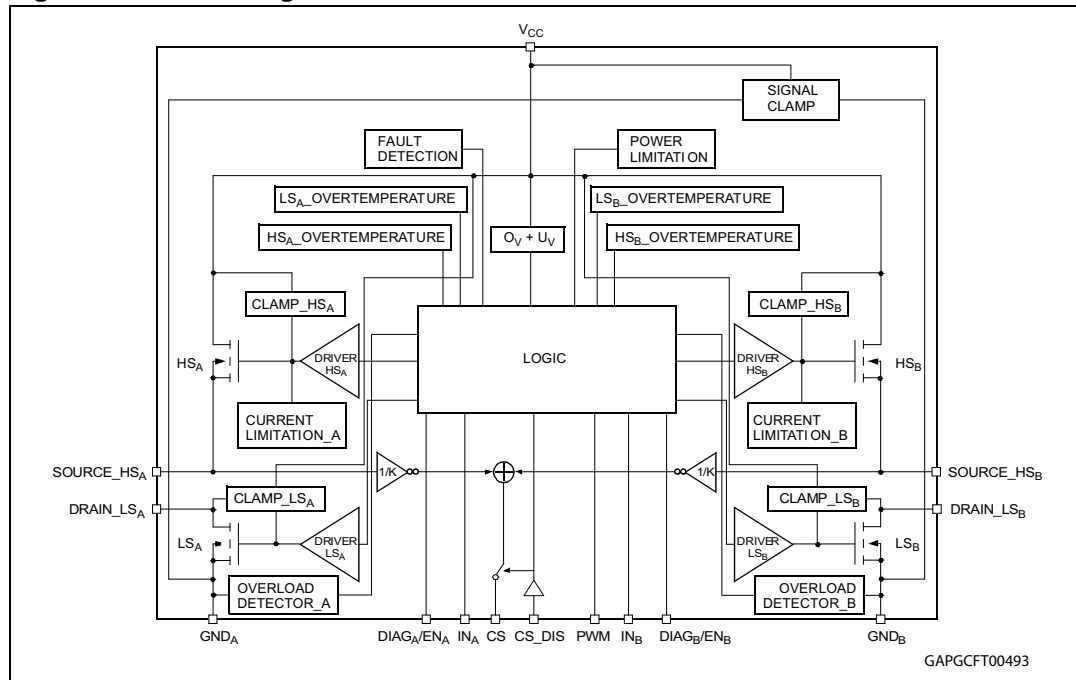

Table 2. Block description

Name	Description
Logic control	Allows the turn-on and the turn-off of the high-side and the low-side switches according to the truth table.
Undervoltage/overvoltage	Shuts down the device for battery voltage outside the range (4,5...24V).
High-side and low-side clamp voltage	Protect the high-side and the low-side switches from high voltage on the battery line.
High-side and low-side driver	Drive the gate of the concerned switch to allow a proper $R_{DS(on)}$ for the leg of the bridge.
Current limitation	Limits the motor current in case of short circuit.
High-side and low-side overtemperature protection	In case of short-circuit with the increase of the junction temperature, it shuts down the concerned driver to prevent degradation and to protect the die.
Low-side overload detector	Detects when low-side current exceeds shutdown current and latches off the concerned low-side.
Fault detection	Signalizes an abnormal condition of the switch (output shorted to ground or output shorted to battery) by pulling down the concerned ENx/DIAGx pin.
Power limitation	Limits the power dissipation of the high-side driver inside safe range in case of short to ground condition.

Table 3. Suggested connections for unused and not connected pins

Connection / pin	Current sense	N.C.	SOURCE_HSx	DRAIN_LSx	INPUTx, PWM DIAGx/ENx CS_DIS
Floating	Not allowed	X	X	X	X
To ground	Through 1 kΩ resistor	X	Not allowed	X	Through 10 kΩ resistor

Figure 2. Configuration diagram (top view)

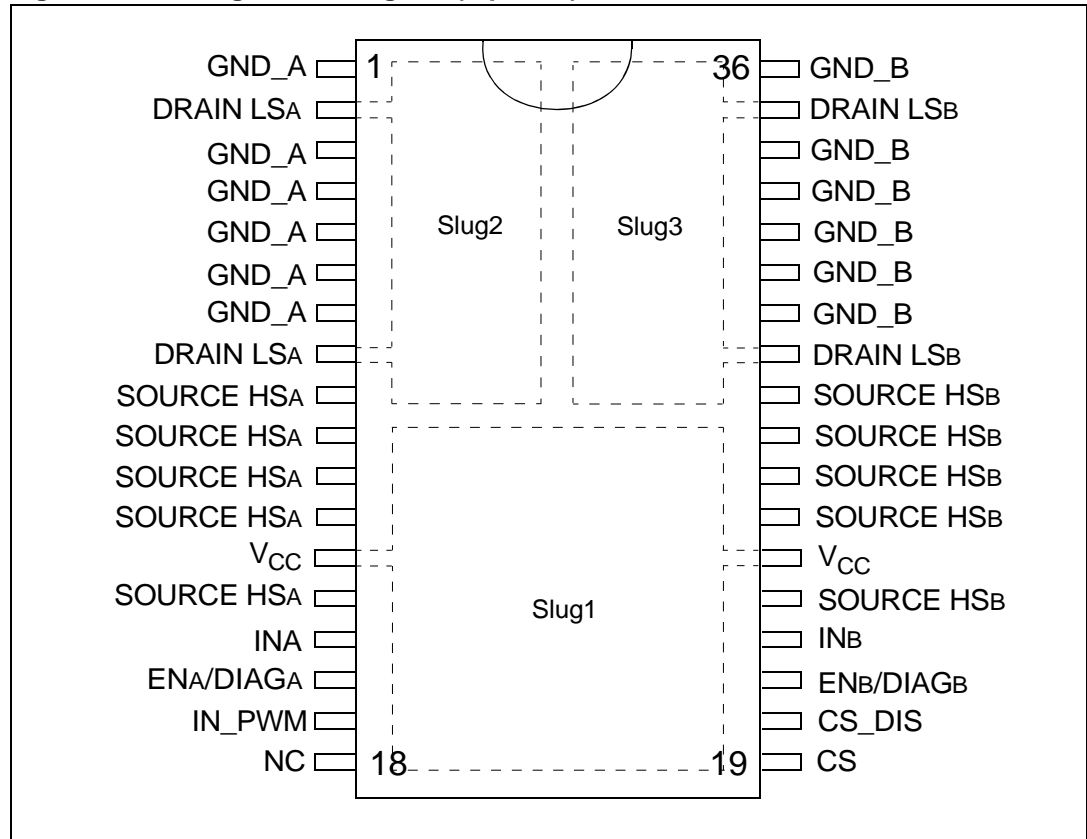

Table 4. Pin definitions and functions

Pin N°	Symbol	Function
13, 24	V _{CC} , Heat slug1	Drain of high-side switches and power supply voltage.
18	NC	Not connected.
15	INA	Clockwise input.
16	ENA/DIAGA	Status of high-side and low-side switches A; Open drain output.
17	IN_PWM	PWM input.
19	CS	Output of current sense.

Table 4. Pin definitions and functions (continued)

Pin N°	Symbol	Function
20	CS_DIS	Active high CMOS compatible pin to disable current sense pin.
21	EN _B /DIAG _B	Status of high-side and low-side switches B; Open drain output.
22	IN _B	Counter clockwise input.
23, 25, 26, 27, 28, 29, 35	OUT _B , Heat Slug3	Source of high-side switch B / drain of low-side switch B.
30, 31, 32, 33, 34,36	GND_B	Source of low-side switch B.
2, 8, 9, 10, 11, 12, 14	OUT _A , Heat Slug2	Source of high-side switch A / drain of low-side switch A.
1, 3, 4, 5, 6, 7	GND_A	Source of low-side switch A.

Table 5. Pin functions description

Name	Description
V _{CC}	Battery connection.
GND	Power ground.
OUT _A OUT _B	Power connections to the motor.
IN _A IN _B	Voltage controlled input pins with hysteresis, CMOS compatible. These two pins control the state of the bridge in normal operation according to the truth table (brake to V _{CC} , Brake to GND, clockwise and counterclockwise).
PWM	Voltage controlled input pin with hysteresis, CMOS compatible. Gates of low-side FETS get modulated by the PWM signal during their on phase allowing speed control of the motor.
EN _A /DIAG _A EN _B /DIAG _B	Open drain bidirectional logic pins. These pins must be connected to an external pull up resistor. When externally pulled low, they disable half-bridge A or B. In case of fault detection (thermal shutdown of a high-side FET or excessive on-state voltage drop across a low-side FET), these pins are pulled low by the device (see truth table in fault condition).
CS	Analog current sense output. This output delivers a current proportional to the motor current if CS_DIS is low or left open. The information can be read back as an analog voltage across an external resistor.
CS_DIS	Active high CMOS compatible pin to disable the current sense pin.

2 Electrical specifications

Figure 3. Current and voltage conventions

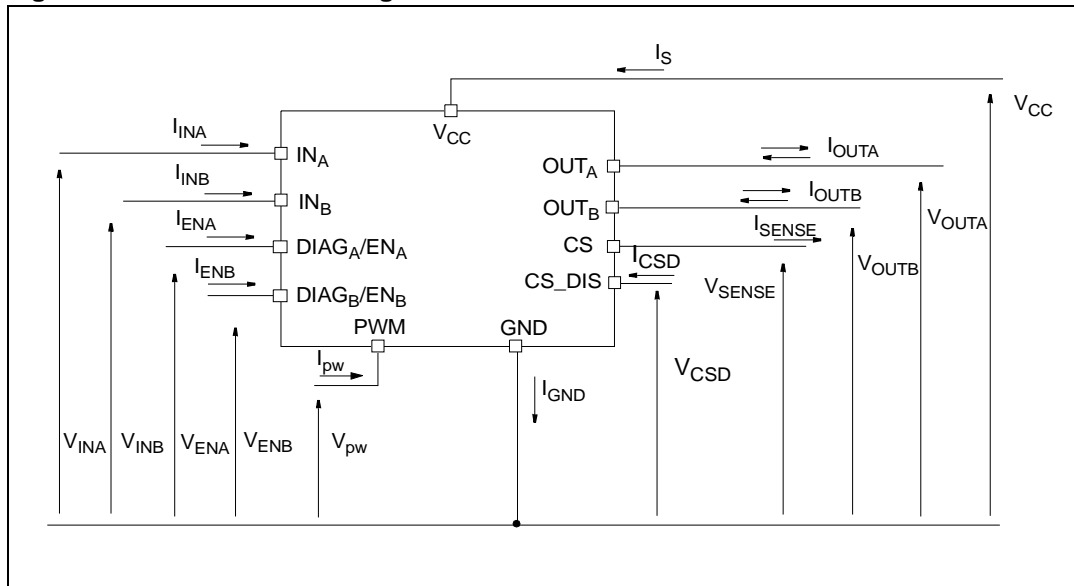

2.1 Absolute maximum ratings

Table 6. Absolute maximum ratings

Symbol	Parameter	Value	Unit
V_{CC}	Supply voltage	+ 41	V
I_{max}	DC output current	Internally limited	A
I_R	Reverse output current (continuous) ⁽¹⁾	25	A
I_{IN}	Input current (IN _A and IN _B pins)	+/- 10	mA
I_{EN}	Enable input current (DIAG _A /EN _A and DIAG _B /EN _B pins)	+/- 10	mA
I_{pw}	PWM Input current	+/- 10	mA
I_{CS_DIS}	CS_DIS input current	+/- 10	mA
V_{CS}	Current sense maximum voltage	$V_{CC}-41/+V_{CC}$	V
V_{ESD}	Electrostatic discharge (Human body model: R = 1.5 kΩ, C = 100 pF)	2	kV
T_c	Junction operating temperature	-40 to 150	°C
T_{STG}	Storage temperature	-55 to 150	°C
I_{GND}	DC reverse ground pin current	200	mA

1. Based on the internal wires capability.

2.2 Thermal data

Table 7. Thermal data

Symbol	Parameter		Max. value	Unit
$R_{thj-case}$	Thermal resistance junction-case (per leg)	HSD	3.7	°C/W
		LSD	3.9	°C/W
$R_{thj-amb}$	Thermal resistance junction-ambient		See Figure 17	°C/W

2.3 Electrical characteristics

$V_{CC} = 9\text{ V}$ up to 18 V ; $-40\text{ °C} < T_j < 150\text{ °C}$, unless otherwise specified.

Table 8. Power section

Symbol	Parameter	Test conditions	Min.	Typ.	Max.	Unit
V_{CC}	Operating supply voltage		5.5		18	V
I_S	Supply current	Off-state with all fault cleared and $EN_x = 0$ (standby) $IN_A = IN_B = PWM = 0$; $T_j = 25\text{ °C}$; $V_{CC} = 13\text{ V}$		3	6	μA
		Off-state with all fault cleared and $EN_x = 0$ (standby) $V_{CC} = 13\text{ V}$; $IN_A = IN_B = PWM = 0$; $T_j = -40\text{ °C}$ to 150 °C			10	μA
		Off-state (no standby) $IN_A = IN_B = PWM = 0$; $EN_x = 5\text{ V}$; $T_j = -40\text{ °C}$ to 150 °C			5	mA
		On-state: IN_A or $IN_B = 5\text{ V}$; no PWM		3	6	mA
		On-state: IN_A or $IN_B = 5\text{ V}$; PWM = 20 kHz			8	mA
R_{ONHS}	Static high-side resistance	$I_{OUT} = 8.5\text{ A}$; $T_j = -40\text{ °C}$		17		m Ω
		$I_{OUT} = 8.5\text{ A}$; $T_j = 25\text{ °C}$		26		m Ω
		$I_{OUT} = 8.5\text{ A}$; $T_j = 150\text{ °C}$		52		m Ω
		$I_{OUT} = 8.5\text{ A}$; $T_j = -40\text{ °C}$ to 150 °C			60	m Ω
R_{ONLS}	Static low-side resistance	$I_{OUT} = 8.5\text{ A}$; $T_j = 25\text{ °C}$		20		m Ω
		$I_{OUT} = 8.5\text{ A}$; $T_j = -40\text{ °C}$ to 150 °C			40	m Ω
V_f	High-side free-wheeling diode forward voltage	$I_{OUT} = -8.5\text{ A}$; $T_j = 150\text{ °C}$		0.7	0.9	V
$I_{L(off)}$	High-side off-state output current (per channel)	$T_j = 25\text{ °C}$; $V_{CC} = 13\text{ V}$; $V_{OUTX} = EN_x = 0\text{ V}$	0		3	μA
		$T_j = 125\text{ °C}$; $V_{CC} = 13\text{ V}$; $V_{OUTX} = EN_x = 0\text{ V}$	0		5	μA
I_{RM}	Dynamic cross-conduction current	$I_{OUT} = 8.5\text{ A}$ (see Figure 7)		1		A

Table 9. Logic inputs (IN_A, IN_B, EN_A, EN_B, PWM, CS_DIS)

Symbol	Parameter	Test conditions	Min.	Typ.	Max.	Unit
V _{IL}	Input low level voltage	Normal operation (DIAG _X /EN _X pin acts as an input pin)			0.9	V
V _{IH}	Input high level voltage	Normal operation (DIAG _X /EN _X pin acts as an input pin)	2.1			V
V _{IHYST}	Input hysteresis voltage	Normal operation (DIAG _X /EN _X pin acts as an input pin)	0.15			V
V _{ICL}	Input clamp voltage	I _{IN} = 1 mA	5.5	6.3	7.5	V
		I _{IN} = -1 mA	-1.0	-0.7	-0.3	V
I _{INL}	Input current	V _{IN} = 0.9 V	1			μA
I _{INH}	Input current	V _{IN} = 2.1 V			10	μA
V _{DIAG}	Enable output low level voltage	Fault operation (DIAG _X /EN _X pin acts as an output pin); I _{EN} = 1 mA			0.4	V

Table 10. Switching (V_{CC} = 13 V, R_{LOAD} = 1.5 Ω)

Symbol	Parameter	Test conditions	Min.	Typ.	Max.	Unit
f	PWM frequency		0		20	kHz
t _{d(on)}	Turn-on delay time	Input rise time < 1 μs (see Figure 6)			250	μs
t _{d(off)}	Turn-off delay time	Input rise time < 1 μs (see Figure 6)			250	μs
t _r	Rise time	See Figure 5		1	2	μs
t _f	Fall time	See Figure 5		1	2	μs
t _{DEL}	Delay time during change of operating mode	See Figure 4	200	400	1600	μs
t _{rr}	High-side free wheeling diode reverse recovery time	See Figure 7		100		ns

Table 11. Protections and diagnostics

Symbol	Parameter	Test conditions	Min.	Typ.	Max.	Unit
V _{USD}	Undervoltage shutdown			3	5	V
V _{USDhyst}	Undervoltage shutdown hysteresis			0.5		V
V _{OV}	V _{CC} overvoltage shutdown		24	27	30	V
I _{LIM_H}	High-side current limitation		30	42	60	A

Table 11. Protections and diagnostics (continued)

Symbol	Parameter	Test conditions	Min.	Typ.	Max.	Unit
I_{SD_LS}	Shutdown LS current		30	50	70	A
V_{CLP}	Total clamp voltage (V_{CC} to GND)	$I_{OUT} = 8.5$ A	41	46	52	V
V_{CLPH}	High-side clamp voltage (V_{CC} to $OUT_A = 0$ or $OUT_B = 0$)	$I_{OUT} = 8.5$ A	41	46	52	V
T_{SD_LS}	Time to shutdown for the low-side			10		μ s
V_{CLPLS}	Low-side clamp voltage ($OUT_A = V_{CC}$ or $OUT_B = V_{CC}$ to GND)	$I_{OUT} = 8.5$ A	25	28	31	V
$T_{TSD}^{(1)}$	Thermal shutdown temperature	$V_{IN} = 2.1$ V	150	175	200	$^{\circ}$ C
$T_{TR}^{(2)}$	Thermal reset temperature		135			$^{\circ}$ C
$T_{HYST}^{(2)}$	Thermal hysteresis ($T_{SD} - T_{TR}$)			16		$^{\circ}$ C
T_{TSD_LS}	Low-side thermal shutdown temperature	$V_{IN} = 0$ V	150	175	200	$^{\circ}$ C

1. T_{TSD} is the minimum threshold temperature between HS and LS
2. Valid for both HSD and LSD.

Table 12. Current sense (9 V < V_{CC} < 18 V)

Symbol	Parameter	Test conditions	Min.	Typ.	Max.	Unit
K_1	I_{OUT}/I_{SENSE}	$I_{OUT} = 5$ A; $V_{SENSE} = 0.8$ V; $V_{CSD} = 0$ V; $T_j = -40$ $^{\circ}$ C to 150 $^{\circ}$ C	4350	5100	6270	
K_2	I_{OUT}/I_{SENSE}	$I_{OUT} = 10$ A; $V_{SENSE} = 1.6$ V; $V_{CSD} = 0$ V; $T_j = -40$ $^{\circ}$ C to 150 $^{\circ}$ C	4350	5030	5870	
K_3	I_{OUT}/I_{SENSE}	$I_{OUT} = 25$ A; $V_{SENSE} = 4$ V; $V_{CSD} = 0$ V; $T_j = -40$ $^{\circ}$ C to 150 $^{\circ}$ C	4100	4930	5490	
$dK_1/K_1^{(1)}$	Analog sense current drift	$I_{OUT} = 5$ A; $V_{SENSE} = 0.8$ V; $V_{CSD} = 0$ V; $T_j = -40$ $^{\circ}$ C to 150 $^{\circ}$ C	-14		14	%
$dK_2/K_2^{(1)}$	Analog sense current drift	$I_{OUT} = 10$ A; $V_{SENSE} = 1.6$ V; $V_{CSD} = 0$ V; $T_j = -40$ $^{\circ}$ C to 150 $^{\circ}$ C	-13		13	%
$dK_3/K_3^{(1)}$	Analog sense current drift	$I_{OUT} = 25$ A; $V_{SENSE} = 4$ V; $V_{CSD} = 0$ V; $T_j = -40$ $^{\circ}$ C to 150 $^{\circ}$ C	-13		13	%

Table 12. Current sense (9 V < V_{CC} < 18 V) (continued)

Symbol	Parameter	Test conditions	Min.	Typ.	Max.	Unit
V _{SENSE}	Max analog sense output voltage	I _{OUT} = 10 A; V _{CSD} = 0 V; R _{SENSE} = 800 Ω	5			V
I _{SENSETYP_500}	Typical analog sense	I _{OUT} = 500 mA; V _{CC} = 13 V; T _j = -40 °C		87		μA
		I _{OUT} = 500 mA; V _{CC} = 13 V; T _j = 25 °C		91		μA
		I _{OUT} = 500 mA; V _{CC} = 13 V; T _j = 150 °C		100		μA
I _{SENSE0}	Analog sense leakage current	I _{OUT} = 0 A; V _{SENSE} = 0 V; V _{CSD} = 5 V; V _{IN} = 0 V; T _j = -40 °C to 150 °C	0		5	μA
		V _{CSD} = 0 V; V _{IN} = 5 V; T _j = -40 °C to 150 °C	0		180	μA
		V _{CSD} = 5 V; V _{IN} = 5 V; I _{OUT} = 8.5 A	0		5	μA
t _{DSENSEH}	Delay response time from falling edge of CS_DIS pin	V _{IN} = 5 V; V _{SENSE} < 4 V, I _{OUT} = 8.5 A; I _{SENSE} = 90 % of I _{SENSEmax} (see Figure 8)			50	μs
t _{DSENSEL}	Delay response time from rising edge of CS_DIS pin	V _{IN} = 5 V; V _{SENSE} < 4 V; I _{OUT} = 8.5 A; I _{SENSE} = 10 % of I _{SENSEmax} (see Figure 8)			20	μs

1. Analog sense current drift is deviation of factor K for a given device over (-40°C to 150°C and 9 V < V_{CC} < 18 V) with respect to its value measured at T_j = 25 °C, V_{CC} = 13 V.

Figure 4. Definition of the delay times measurement

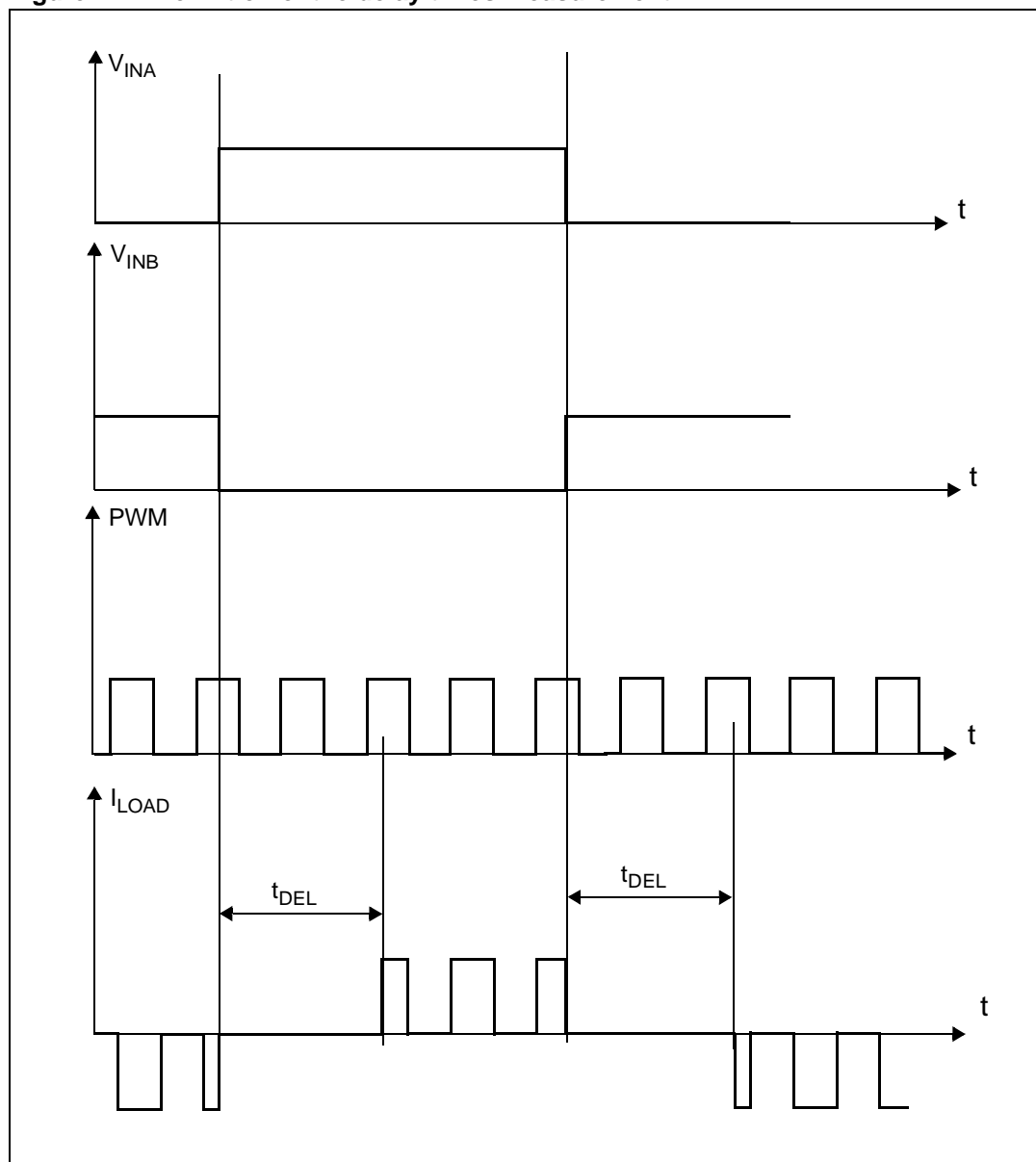

Figure 5. Definition of the low-side switching times

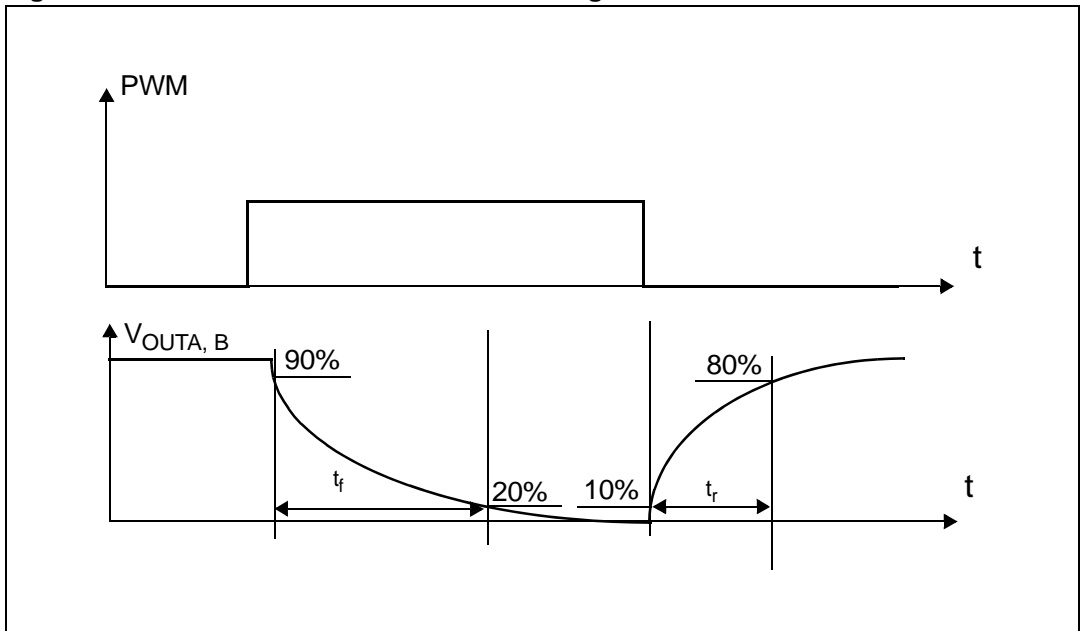

Figure 6. Definition of the high-side switching times

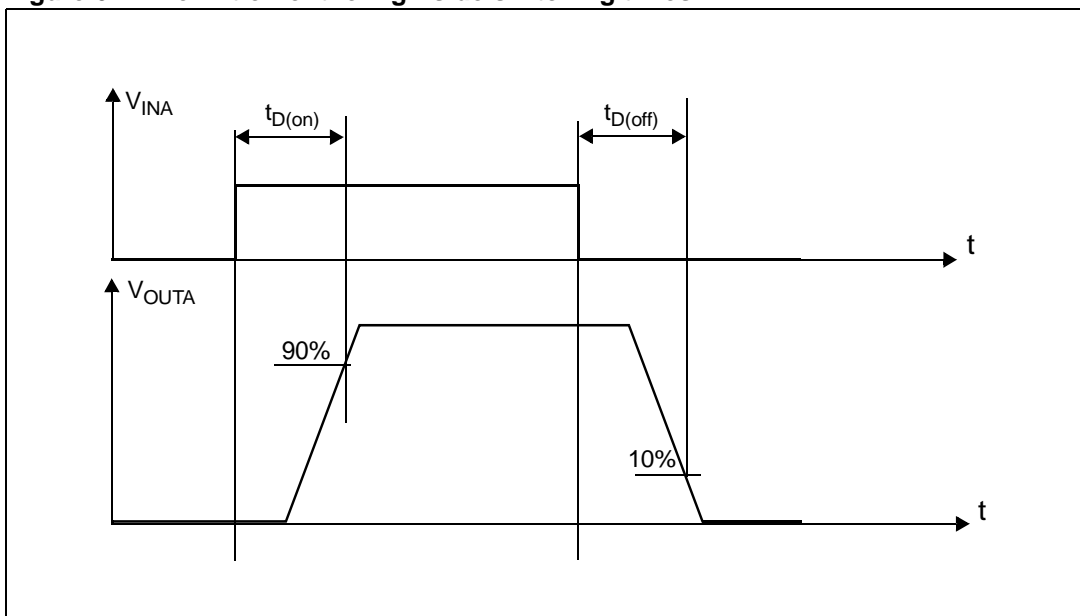

Figure 7. Definition of dynamic cross conduction current during a PWM operation

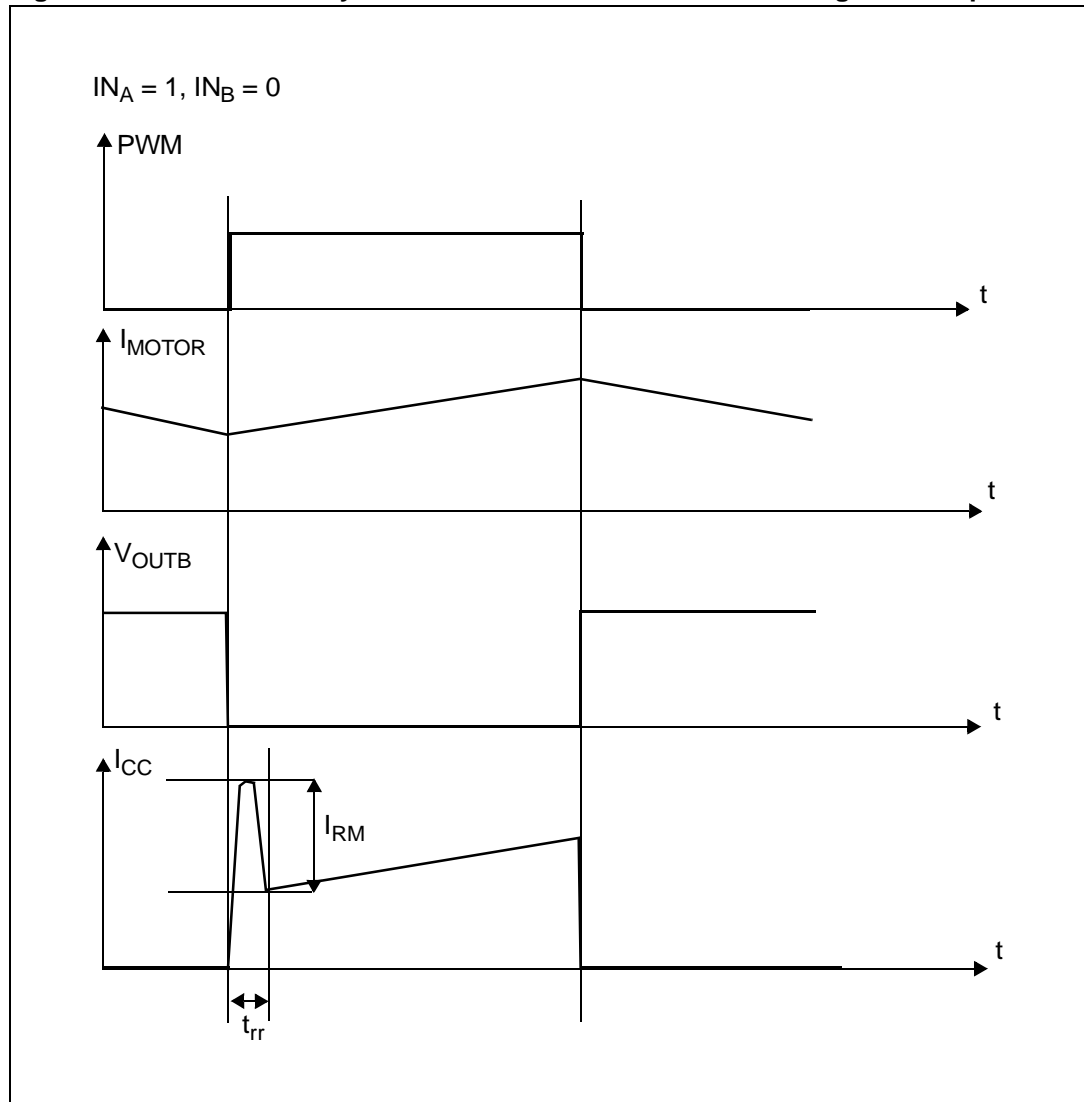

Figure 8. Definition of delay response time of sense current

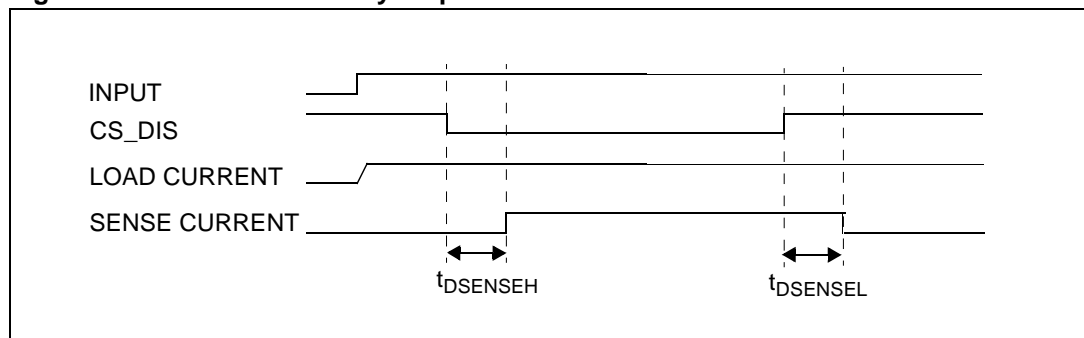

Table 13. Truth table in normal operating conditions

IN _A	IN _B	DIAG _A /EN _A	DIAG _B /EN _B	OUT _A	OUT _B	CS	Operating mode
1	1	1	1	H	H	High Imp.	Brake to V _{CC}
	L				I _{SENSE} = I _{OUT} /K	Clockwise (CW)	
0	1			L		H	Counterclockwise (CCW)
	0			L	L	High Imp.	Brake to GND

Table 14. Truth table in fault conditions (detected on OUT_A)

IN _A	IN _B	DIAG _A /EN _A	DIAG _B /EN _B	OUT _A	OUT _B	CS (V _{CSD} =0V)
1	1	0	1	OPEN	H	High impedance
	0				L	
0	1				L	I _{OUTB} /K
	0				L	High impedance
X	X		0	OPEN		

↑
Fault Information
↑
Protection Action

Note: In normal operating conditions the DIAG_X/EN_X pin is considered as an input pin by the device. This pin must be externally pulled high.

Table 15. Electrical transient requirements (part 1/3)

ISO 7637-2: 2004(E) Test pulse	Test levels ⁽¹⁾		Number of pulses or test times	Burst cycle/pulse repetition time		Delays and Impedance
	III	IV		Min.	Max.	
1	-75V	-100V	5000 pulses	0.5s	5s	2 ms, 10Ω
2a	+37V	+50V	5000 pulses	0.2s	5s	50μs, 2Ω
3a	-100V	-150V	1h	90ms	100ms	0.1μs, 50Ω
3b	+75V	+100V	1h	90ms	100ms	0.1μs, 50Ω
4	-6V	-7V	1 pulse			100ms, 0.01Ω
5b ⁽²⁾	+65V	+87V	1 pulse			400ms, 2Ω

1. The above test levels must be considered referred to $V_{CC} = 13.5V$ except for pulse 5b.
2. Valid in case of external load dump clamp: 40V maximum referred to ground.

Table 16. Electrical transient requirements (part 2/3)

ISO 7637-2: 2004E Test pulse	Test level results	
	III	VI
1	C	C
2a	C	C
3a	C	C
3b	C	C
4	C	C
5b ⁽¹⁾	C	C

1. Valid in case of external load dump clamp: 40V maximum referred to ground.

Table 17. Electrical transient requirements (part 3/3)

Class	Contents
C	All functions of the device performed as designed after exposure to disturbance.
E	One or more functions of the device did not perform as designed after exposure to disturbance and cannot be returned to proper operation without replacing the device.

2.4 Waveforms

Figure 9. Waveforms in full-bridge operation

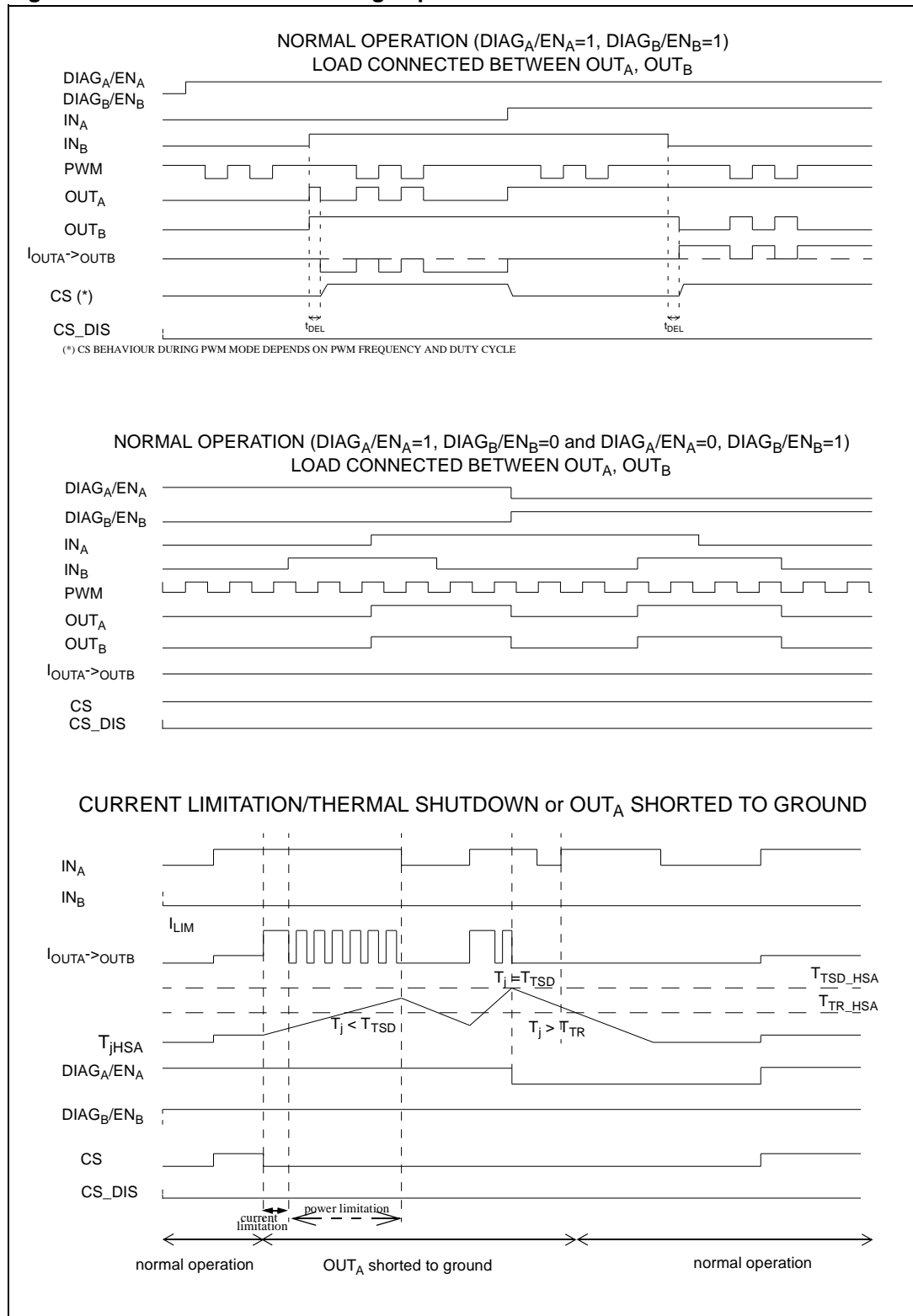
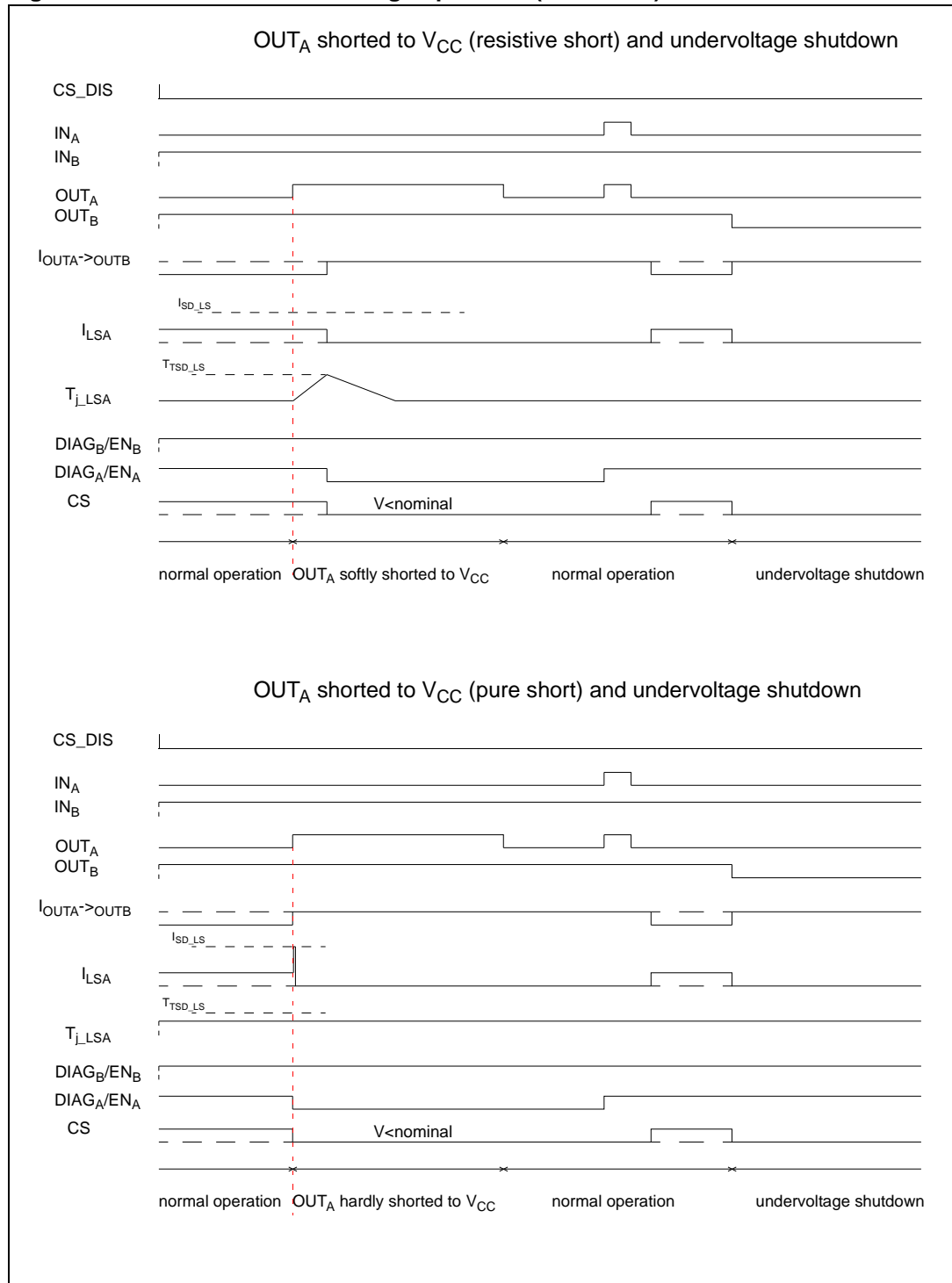

Figure 10. Waveforms in full-bridge operation (continued)



3 Application information

In normal operating conditions the DIAG_X/EN_X pin is considered as an input pin by the device. This pin must be externally pulled high.

PWM pin usage: In all cases, a “0” on the PWM pin turns off both LS_A and LS_B switches. When PWM rises back to “1”, LS_A or LS_B turn on again depending on the input pin state.

Figure 11. Typical application circuit for DC to 20 kHz PWM operation short circuit protection

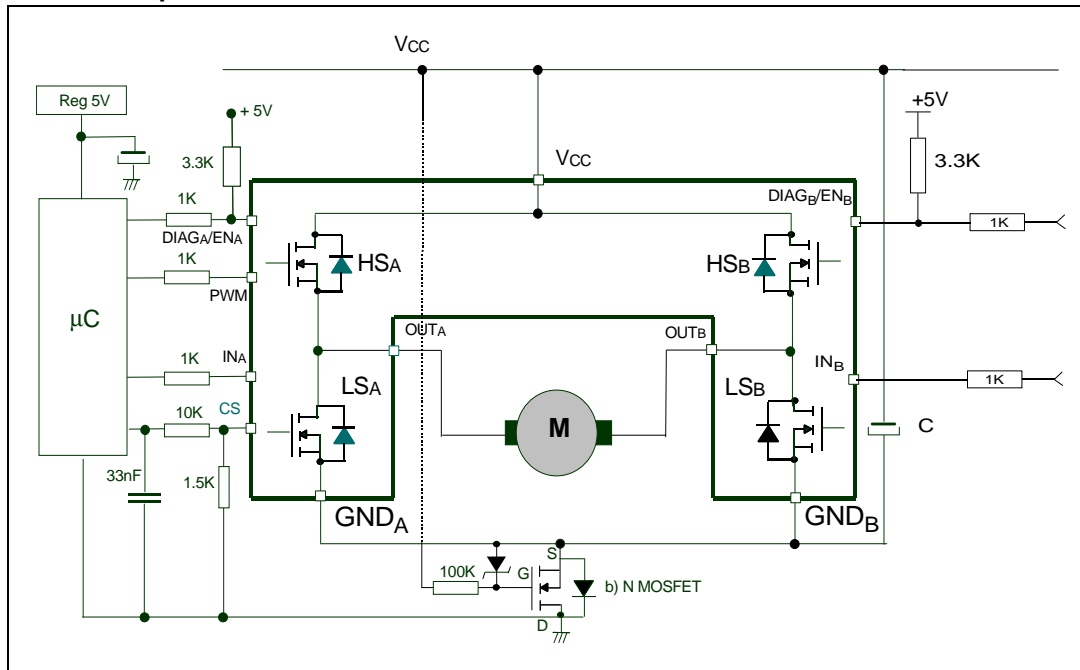

Note: The value of the blocking capacitor (C) depends on the application conditions and defines voltage and current ripple on supply line at PWM operation. Stored energy of the motor inductance may fly back into the blocking capacitor, if the bridge driver goes into 3-state. This causes a hazardous overvoltage if the capacitor is not big enough. As basic orientation, 500µF per 10A load current is recommended.

In case of a fault condition the DIAG_X/EN_X pin is considered as an output pin by the device.

The fault conditions are:

- Overtemperature on one or both high-sides
- Short to battery condition on the output (over current detection on the low-side Power MOSFET)

Possible origins of fault conditions may be:

OUT_A is shorted to ground → overtemperature detection on high-side A

OUT_A is shorted to V_{CC} → low-side Power MOSFET over current detection

When a fault condition is detected, the user can identify which power element is in fault by monitoring the IN_A, IN_B, DIAG_A/EN_A and DIAG_B/EN_B pins.

In any case, when a fault is detected, the faulty leg of the bridge is latched off. To turn on the respective output (OUT_x) again, the input signal must rise from low to high level.

Figure 12. Behavior in fault condition (how a fault can be cleared)

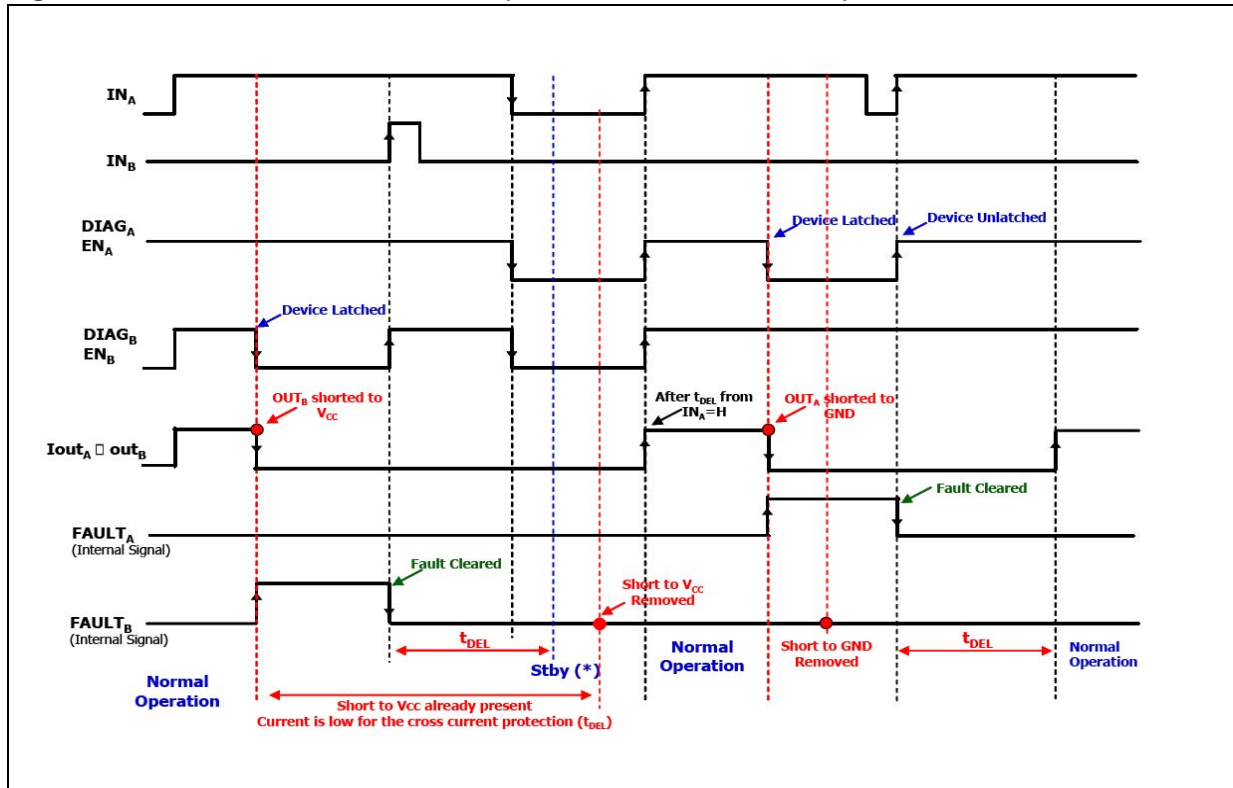

Note: In case of the fault condition is not removed, the procedure for unlatching and sending the device in Stby mode is:

- Clear the fault in the device (toggle: IN_A if EN_A = 0 or IN_B if EN_B = 0)
- Pull low all inputs, PWM and Diag/EN pins within t_{DEL}.

If the Diag/En pins are already low, PWM = 0, the fault can be cleared simply toggling the input. The device enters in stby mode as soon as the fault is cleared.

3.1 Reverse battery protection

Three possible solutions can be considered:

- A Schottky diode D connected to V_{CC} pin
- An N-channel MOSFET connected to the GND pin (see [Figure 11](#))
- A P-channel MOSFET connected to the V_{CC} pin

The device sustains no more than -25 A in reverse battery conditions because of the two body diodes of the Power MOSFETs. Additionally, in reverse battery condition the I/Os of VNH5050A-E is pulled down to the V_{CC} line (approximately -1.5 V).

Series resistor must be inserted to limit the current sunk from the microcontroller I/Os. If I_{Rmax} is the maximum target reverse current through μC I/Os, series resistor is:

$$R = \frac{V_{IOs} - V_{CC}}{I_{Rmax}}$$

Figure 13. Half-bridge configuration

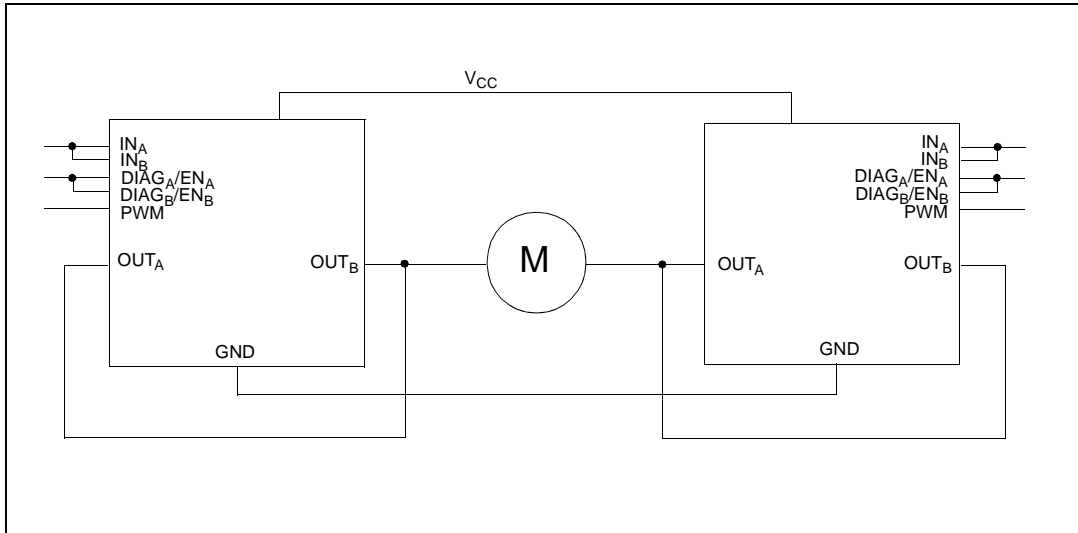

Note: The VNH5050A-E can be used as a high power half-bridge driver.

Figure 14. Multi-motors configuration

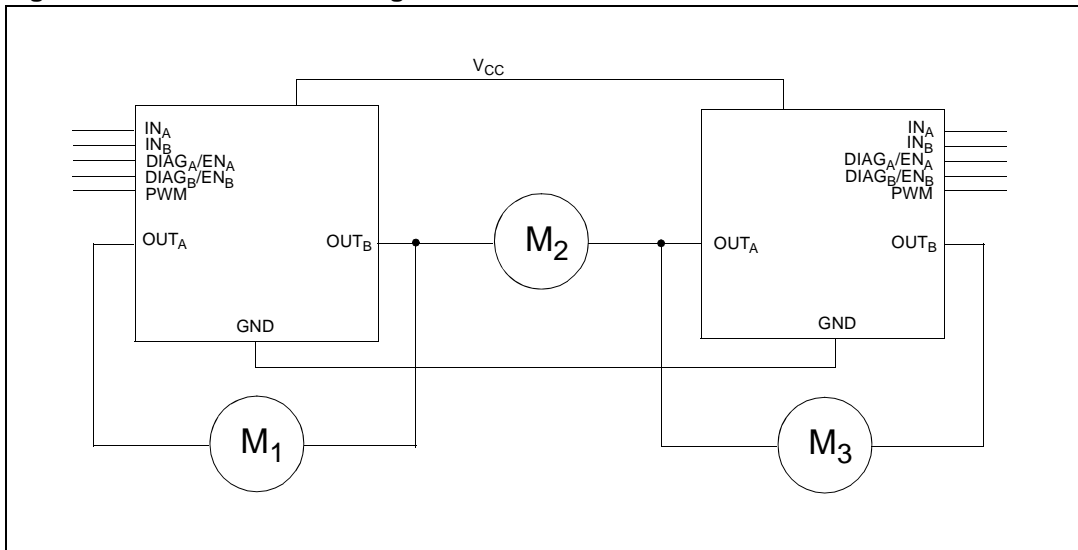

Note: The VNH5050A-E can easily be designed in multi-motors driving applications such as seat positioning systems where only one motor has to be driven at a time. $DIAG_X/EN_X$ pins allow to put unused half-bridges in high impedance.

4 Package and PCB thermal data

4.1 PowerSSO-36 thermal data

Figure 15. PowerSSO-36™ PC board

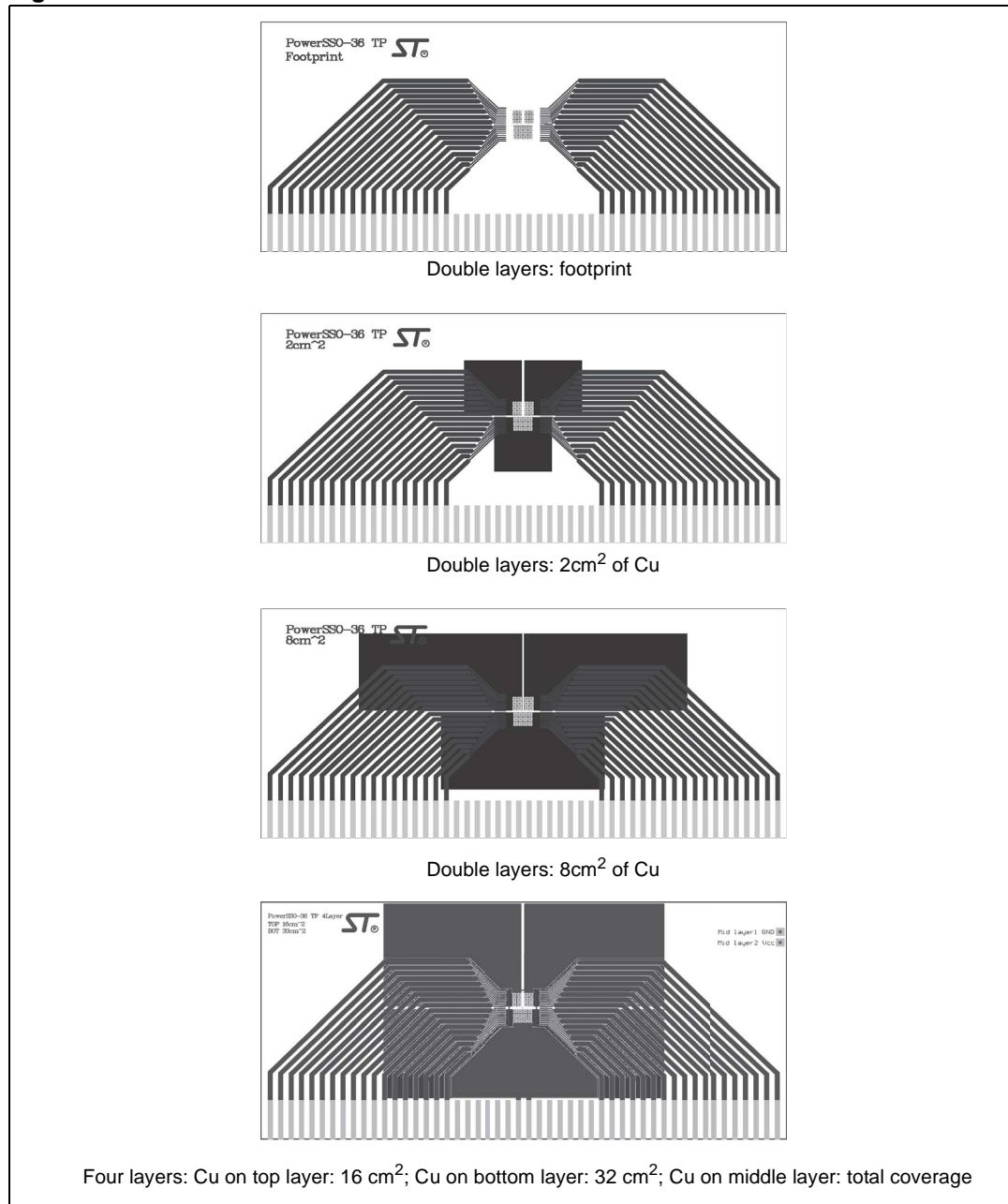

Note: Board finish thickness 1.6 mm +/- 10%, Board double layers and four layers, Board dimension 129x60, Board Material FR4, Cu thickness 0.070mm (front and back side), Thermal vias spaced on a 1.2 mm x 1.2 mm grid, Vias pad clearance thickness 0.2 mm, Thermal via diameter 0.3 mm +/- 0.08 mm, Cu thickness on vias 0.025 mm, Footprint dimension 4.1 mm x 6.5 mm.

Figure 16. Chipset configuration

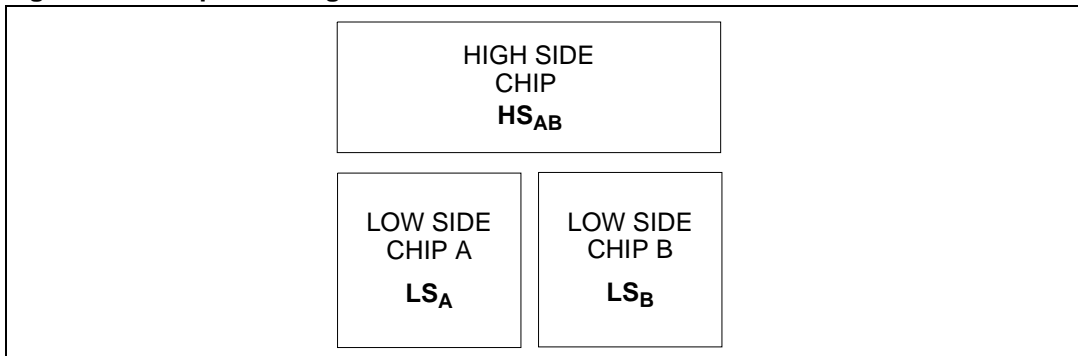
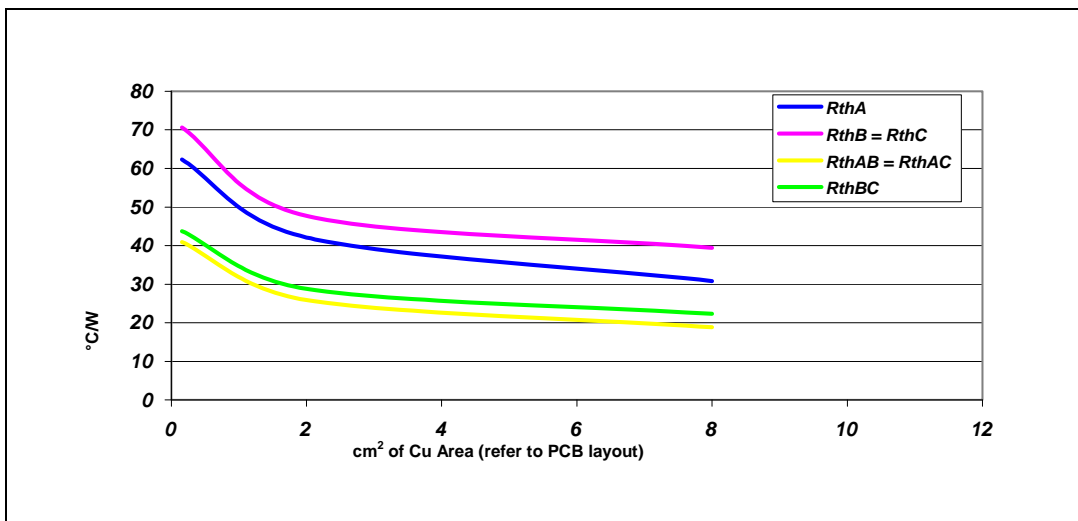

Figure 17. Auto and mutual R_{thj-amb} vs PCB copper area in open box free air condition



4.1.1 Thermal calculation in clockwise and anti-clockwise operation in steady-state mode

Table 18. Thermal calculation in clockwise and anti-clockwise operation in steady-state mode

HS _A	HS _B	LS _A	LS _B	T _{jHSAB}	T _{jLSA}	T _{jLSB}
ON	OFF	OFF	ON	$P_{dHSA} \times R_{thHS} + P_{dLSB} \times R_{thHSL} + T_{amb}$	$P_{dHSA} \times R_{thHSL} + P_{dLSB} \times R_{thLSL} + T_{amb}$	$P_{dHSA} \times R_{thHSL} + P_{dLSB} \times R_{thLS} + T_{amb}$
OFF	ON	ON	OFF	$P_{dHSB} \times R_{thHS} + P_{dLSA} \times R_{thHSL} + T_{amb}$	$P_{dHSB} \times R_{thHSL} + P_{dLSA} \times R_{thLS} + T_{amb}$	$P_{dHSB} \times R_{thHSL} + P_{dLSA} \times R_{thLSL} + T_{amb}$

4.1.2 Thermal resistances definition (values according to the PCB heatsink area)

R_{thHS} = R_{thHSA} = R_{thHSB} = High Side Chip Thermal Resistance Junction to Ambient (HS_A or HS_B in ON state)

R_{thLS} = R_{thLSA} = R_{thLSB} = Low Side Chip Thermal Resistance Junction to Ambient

$R_{thHSLs} = R_{thHSALsB} = R_{thHSBLsA} =$ Mutual Thermal Resistance Junction to Ambient between High Side and Low Side Chips

$R_{thLSLs} = R_{thLSALsB} =$ Mutual Thermal Resistance Junction to Ambient between Low Side Chips

4.1.3 Thermal calculation in transient mode^(a)

$$T_{jHSAB} = Z_{thHS} \times P_{dHSAB} + Z_{thHSLs} \times (P_{dLSA} + P_{dLSB}) + T_{amb}$$

$$T_{jLSA} = Z_{thHSLs} \times P_{dHSAB} + Z_{thLS} \times P_{dLSA} + Z_{thLSLs} \times P_{dLSB} + T_{amb}$$

$$T_{jLSB} = Z_{thHSLs} \times P_{dHSAB} + Z_{thLSLs} \times P_{dLSA} + Z_{thLS} \times P_{dLSB} + T_{amb}$$

Single pulse thermal impedance definition (values according to the PCB heatsink area).

$Z_{thHS} =$ High Side Chip Thermal Impedance Junction to Ambient

$Z_{thLS} = Z_{thLSA} = Z_{thLSB} =$ Low Side Chip Thermal Impedance Junction to Ambient

$Z_{thHSLs} = Z_{thHSABLSA} = Z_{thHSABLsB} =$ Mutual Thermal Impedance Junction to Ambient between High Side and Low Side Chips

$Z_{thLSLs} = Z_{thLSALsB} =$ Mutual Thermal Impedance Junction to Ambient between Low Side Chips

Figure 18. Detailed chipset configuration

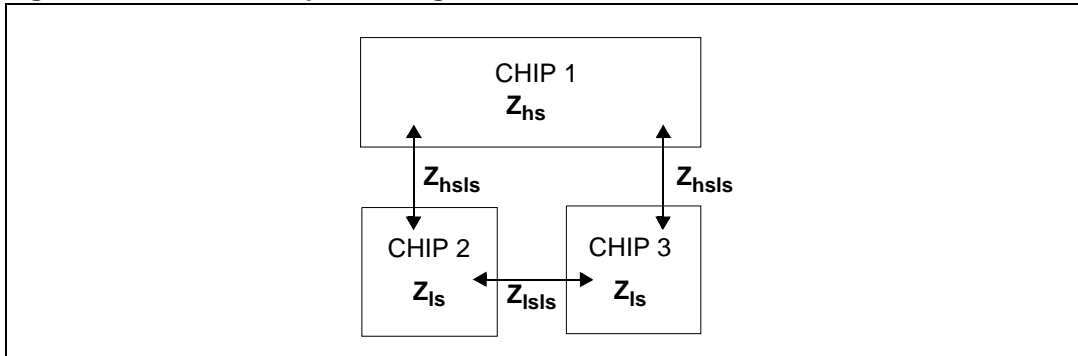

Equation 1: pulse calculation formula

$$Z_{TH\delta} = R_{TH} \cdot (\delta + Z_{THtp}(1 - \delta))$$

where $\delta = t_p/T$

a. Calculation is valid in any dynamic operating condition. P_d values set by user.

Figure 19. PowerSSO-36 HSD thermal impedance junction ambient single pulse

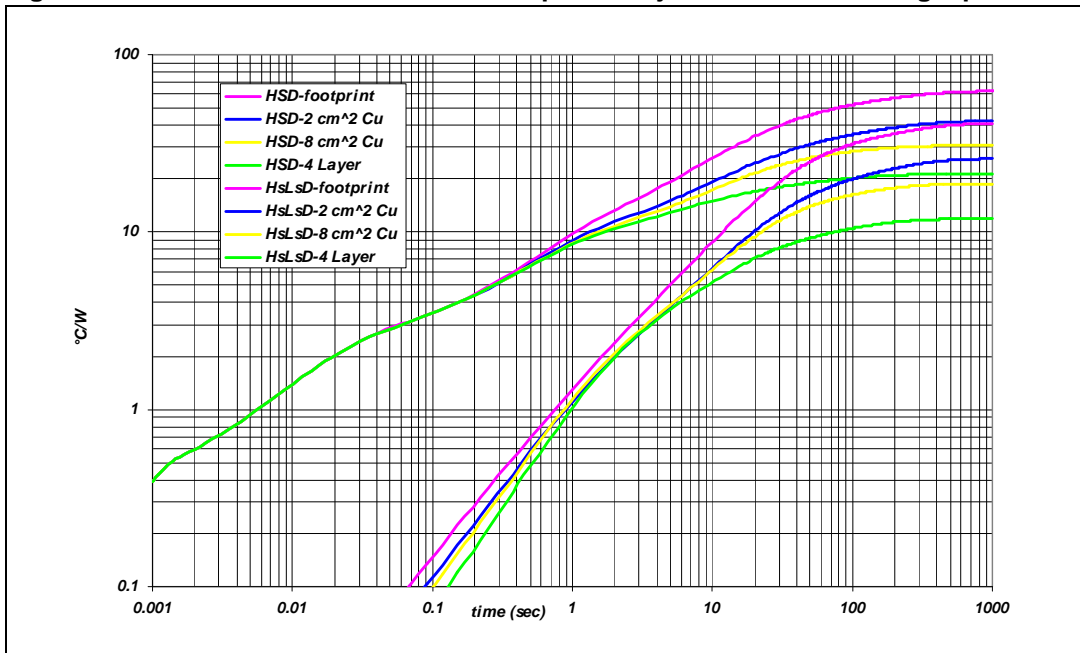

Figure 20. PowerSSO-36 LSD thermal impedance junction ambient single pulse

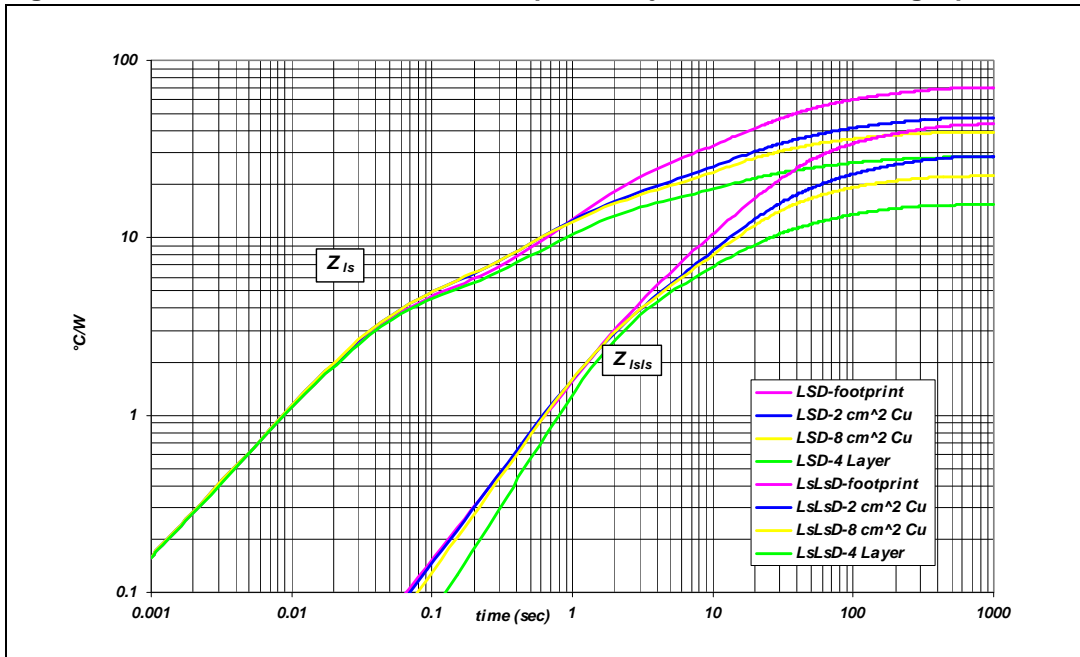

Figure 21. Thermal fitting model of an H-bridge in PowerSSO-36

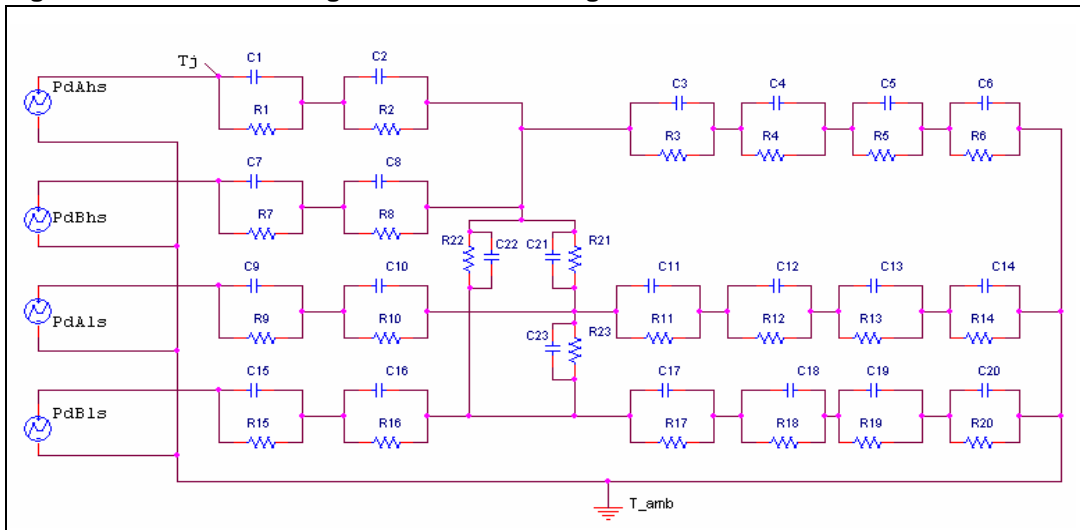

Table 19. Thermal parameters⁽¹⁾

Area/island (cm ²)	Footprint	2	8	4L
R1 = R7 (°C/W)	0.4			
R2 = R8 (°C/W)	2			
R3 (°C/W)	8			
R4 (°C/W)	30	16	16	10
R5 (°C/W)	40	22	12	5
R6 (°C/W)	36	28	10	6
R9 = R15 (°C/W)	0.1			
R10 = R16 (°C/W)	3.6			
R11 = R17 (°C/W)	22	14	14	14
R12 = R18 (°C/W)	49	30	30	20
R13 = R19 (°C/W)	52	36	28	16
R14 = R20 (°C/W)	50	32	26	18
R21 = R22 (°C/W)	80	60	50	40
R23 (°C/W)	80	50	45	30
C1 = C7 = C9 = C15 (W.s/°C)	0.0005			
C2 = C8 (W.s/°C)	0.008			
C3 (W.s/°C)	0.09			
C4 (W.s/°C)	0.5	0.8	0.8	0.8
C5 (W.s/°C)	0.8	1.4	2	3
C6 (W.s/°C)	5	6	8	10
C10 = C16 (W.s/°C)	0.009			
C11 = C17 (W.s/°C)	0.07			
C12 = C18 (W.s/°C)	0.45	0.45	0.45	0.6
C13 = C19 (W.s/°C)	0.8	1	1.2	2.5
C14 = C20 (W.s/°C)	4	5	6	8
C21 = C22 = C23 (W.s/°C)	0.01	0.006	0.005	0.005

1. The blank space means that the value is the same as the previous one.

5 Package and packing information

5.1 ECOPACK® packages

In order to meet environmental requirements, ST offers these devices in different grades of ECOPACK® packages, depending on their level of environmental compliance. ECOPACK® specifications, grade definitions and product status are available at: www.st.com.

ECOPACK® is an ST trademark.

5.2 PowerSSO-36 TP package information

Figure 22. PowerSSO-36 TP package dimensions

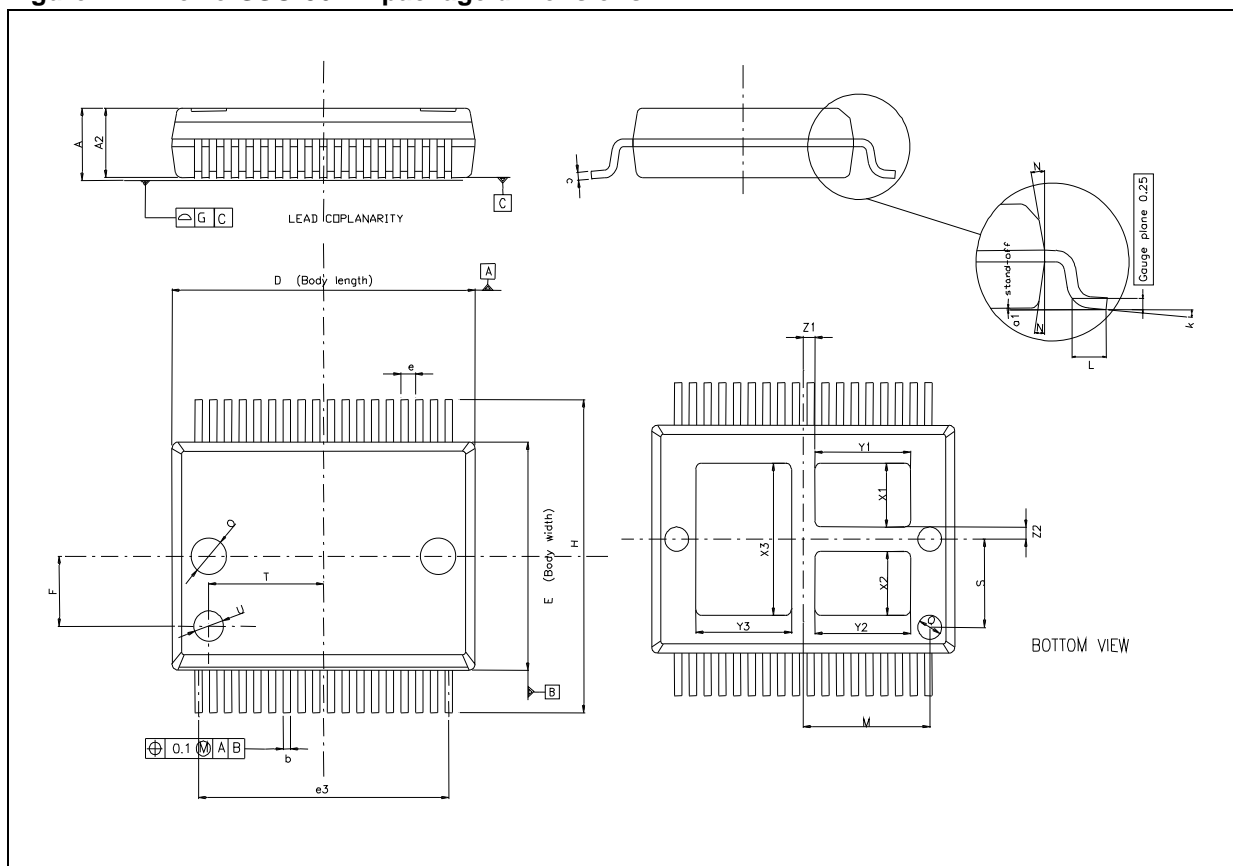

Table 20. PowerSSO-36 TP mechanical data

Symbol	Millimeters		
	Min.	Typ.	Max.
A	2.15	-	2.47
A2	2.15	-	2.40
a1	0	-	0.1
b	0.18	-	0.36
c	0.23	-	0.32
D	10.10	-	10.50
E	7.4	-	7.6
e	-	0.5	-
e3	-	8.5	-
F		2.3	
G	-	-	0.1
H	10.1	-	10.5
h	-	-	0.4
k	0 deg		8 deg
L	0.6	-	1
M		4.3	
N	-	-	10 deg
O		1.2	
Q		0.8	
S		2.9	
T		3.65	
U		1.0	
X1	1.85		2.35
Y1	3		3.5
X2	1.85		2.35
Y2	3		3.5
X3	4.7	-	5.2
Y3	3	-	3.5
Z1		0.4	
Z2		0.4	

5.3 PowerSSO-36 TP packing information

Figure 23. PowerSSO-36 TP tube shipment (no suffix)

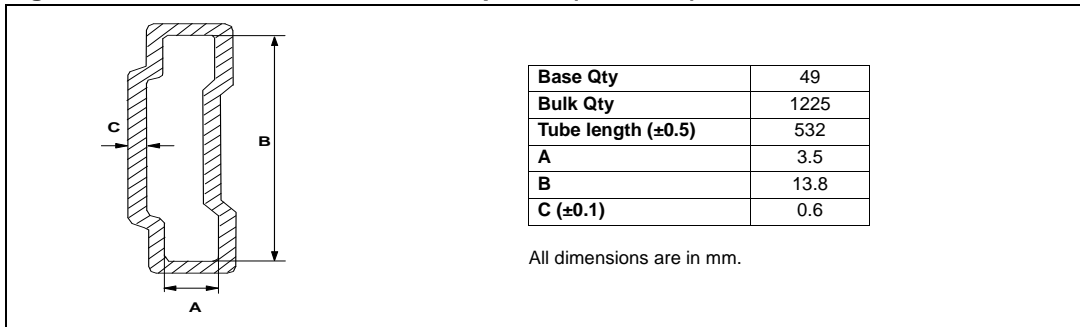
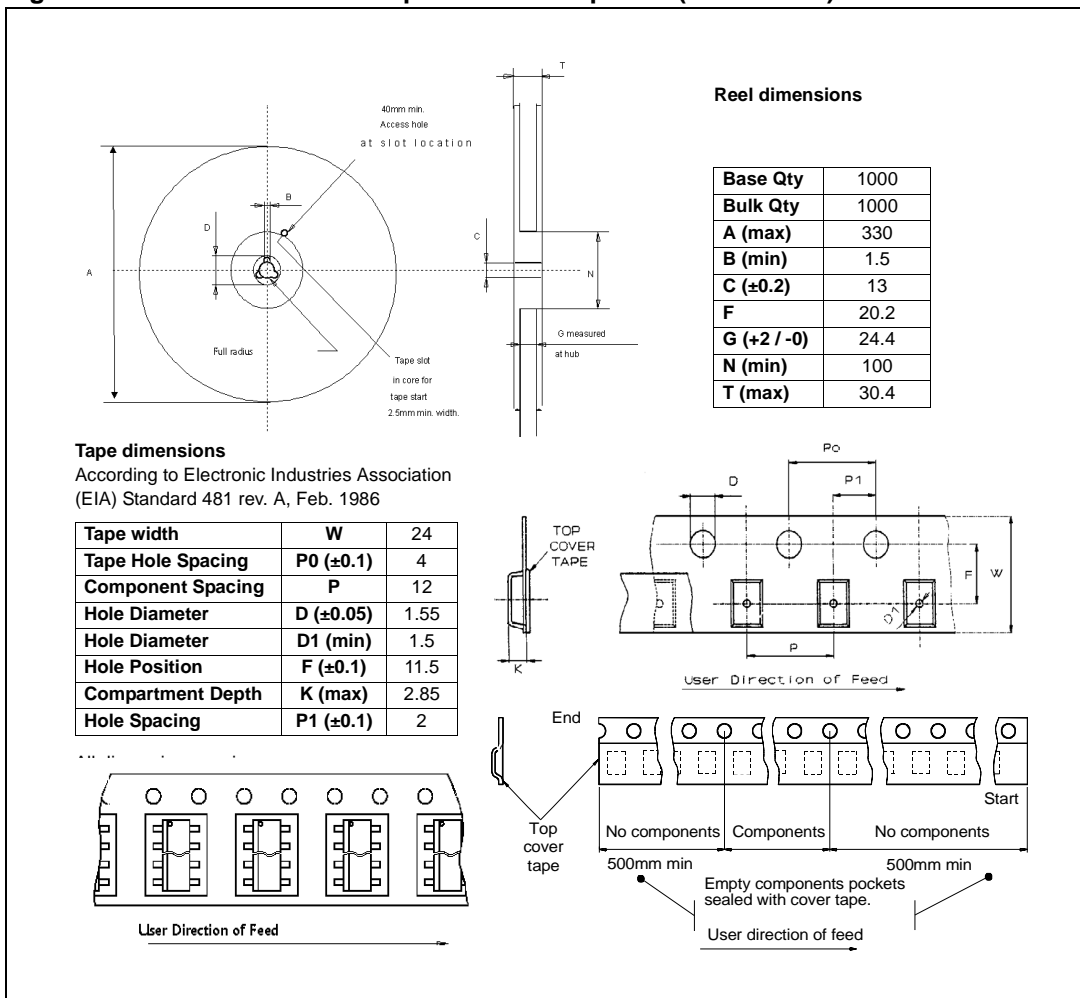

Figure 24. PowerSSO-36 TP tape and reel shipment (suffix "TR")



6 Revision history

Table 21. Document revision history

Date	Revision	Description of changes
06-Jul-2009	1	Initial release.
15-Sep-2009	2	Updated Figure 1: Block diagram . Updated following tables: – Table 2: Block description – Table 6: Absolute maximum ratings – Table 8: Power section – Table 11: Protections and diagnostics – Table 12: Current sense (9 V < V_{CC} < 18 V) – Table 14: Truth table in fault conditions (detected on OUTA) Updated Chapter 3: Application information . Modified Table 12: Current sense (9 V < V_{CC} < 18 V) .
02-Dec-2009	3	Updated following tables: – Table 8: Power section – Table 10: Switching (V_{CC} = 13 V, R_{LOAD} = 1.5 Ω) – Table 11: Protections and diagnostics – Table 12: Current sense (9 V < V_{CC} < 18 V) Added Chapter 4: Package and PCB thermal data
16-Dec-2009	4	Updated Table 4: Pin definitions and functions
02-Mar-2010	5	Updated Table 14: Truth table in fault conditions (detected on OUTA) .
30-Apr-2010	6	Updated following tables: – Table 10: Switching (V_{CC} = 13 V, R_{LOAD} = 1.5 Ω) – Table 11: Protections and diagnostics
30-Jun-2010	7	Updated following tables: – Table 7: Thermal data – Table 8: Power section – Table 12: Current sense (9 V < V_{CC} < 18 V)
05-Jul-2010	8	Updated Table 19: Thermal parameters .
19-Oct-2010	9	Updated Table 12: Current sense (9 V < V_{CC} < 18 V) Updated Section 4.1.3: Thermal calculation in transient mode Added Figure 18: Detailed chipset configuration
22-Dec-2011	10	Updated Figure 1: Block diagram Added Table 3: Suggested connections for unused and not connected pins Table 11: Protections and diagnostics: – T _{TSD} , T _{TR} , T _{HYST} : added note Updated Figure 9: Waveforms in full-bridge operation and Figure 10: Waveforms in full-bridge operation (continued)
19-Sep-2013	11	Updated Disclaimer.

Please Read Carefully:

Information in this document is provided solely in connection with ST products. STMicroelectronics NV and its subsidiaries ("ST") reserve the right to make changes, corrections, modifications or improvements, to this document, and the products and services described herein at any time, without notice.

All ST products are sold pursuant to ST's terms and conditions of sale.

Purchasers are solely responsible for the choice, selection and use of the ST products and services described herein, and ST assumes no liability whatsoever relating to the choice, selection or use of the ST products and services described herein.

No license, express or implied, by estoppel or otherwise, to any intellectual property rights is granted under this document. If any part of this document refers to any third party products or services it shall not be deemed a license grant by ST for the use of such third party products or services, or any intellectual property contained therein or considered as a warranty covering the use in any manner whatsoever of such third party products or services or any intellectual property contained therein.

UNLESS OTHERWISE SET FORTH IN ST'S TERMS AND CONDITIONS OF SALE ST DISCLAIMS ANY EXPRESS OR IMPLIED WARRANTY WITH RESPECT TO THE USE AND/OR SALE OF ST PRODUCTS INCLUDING WITHOUT LIMITATION IMPLIED WARRANTIES OF MERCHANTABILITY, FITNESS FOR A PARTICULAR PURPOSE (AND THEIR EQUIVALENTS UNDER THE LAWS OF ANY JURISDICTION), OR INFRINGEMENT OF ANY PATENT, COPYRIGHT OR OTHER INTELLECTUAL PROPERTY RIGHT.

ST PRODUCTS ARE NOT DESIGNED OR AUTHORIZED FOR USE IN: (A) SAFETY CRITICAL APPLICATIONS SUCH AS LIFE SUPPORTING, ACTIVE IMPLANTED DEVICES OR SYSTEMS WITH PRODUCT FUNCTIONAL SAFETY REQUIREMENTS; (B) AERONAUTIC APPLICATIONS; (C) AUTOMOTIVE APPLICATIONS OR ENVIRONMENTS, AND/OR (D) AEROSPACE APPLICATIONS OR ENVIRONMENTS. WHERE ST PRODUCTS ARE NOT DESIGNED FOR SUCH USE, THE PURCHASER SHALL USE PRODUCTS AT PURCHASER'S SOLE RISK, EVEN IF ST HAS BEEN INFORMED IN WRITING OF SUCH USAGE, UNLESS A PRODUCT IS EXPRESSLY DESIGNATED BY ST AS BEING INTENDED FOR "AUTOMOTIVE, AUTOMOTIVE SAFETY OR MEDICAL" INDUSTRY DOMAINS ACCORDING TO ST PRODUCT DESIGN SPECIFICATIONS. PRODUCTS FORMALLY ESCC, QML OR JAN QUALIFIED ARE DEEMED SUITABLE FOR USE IN AEROSPACE BY THE CORRESPONDING GOVERNMENTAL AGENCY.

Resale of ST products with provisions different from the statements and/or technical features set forth in this document shall immediately void any warranty granted by ST for the ST product or service described herein and shall not create or extend in any manner whatsoever, any liability of ST.

ST and the ST logo are trademarks or registered trademarks of ST in various countries.

Information in this document supersedes and replaces all information previously supplied.

The ST logo is a registered trademark of STMicroelectronics. All other names are the property of their respective owners.

© 2013 STMicroelectronics - All rights reserved

STMicroelectronics group of companies

Australia - Belgium - Brazil - Canada - China - Czech Republic - Finland - France - Germany - Hong Kong - India - Israel - Italy - Japan - Malaysia - Malta - Morocco - Philippines - Singapore - Spain - Sweden - Switzerland - United Kingdom - United States of America

www.st.com