

THIS DRAWING IS UNPUBLISHED. RELEASED FOR PUBLICATION
 © COPYRIGHT - By - ALL RIGHTS RESERVED.

LOC	DIST	REVISIONS					
		P	LTR	DESCRIPTION	DATE	DWN	APVD
			A	INITIAL DRAWING	09JUN10	ZJ	GL
			A1	ECR-11-014219	04OCT2011	TB	SK

NOTES:

- 1 PACKAGING: ACC. TO TE SPEC. 107-18032
- 2 ELECTRICAL TEST ACCORDING TE SPECIFICATION 108-18857.
SHORT-CIRCUIT AND CONTINUITY TEST AT 500V DC, 0.1s
- 3 WIRING SCHEMA ACC. TO TIA/EIA-568-B AS SHOWN IN WIRING SCHEDULE

LENGTH L [m]	TE PN
0.3	2083112-1
1	2083112-2
2	2083112-3
3	2083112-4
5	2083112-5

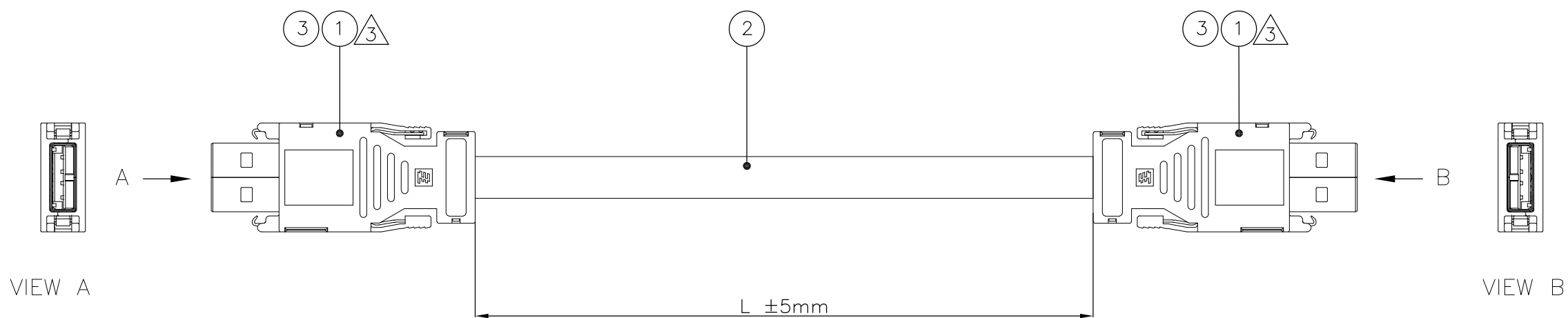

WIRING SCHEDULE 3

CAVITY SIDE A	COLOR	CAVITY SIDE B
1	RD	1
2	WH	2
3	GN	3
4	BK	4

0.014	m	VERSAFIT-1/4-0-SP	3
AR	m	CABLE USB 1PAWG28+2CAWG24 BK	2
2	pc	INDUSTRIAL USB PLUG CONN KIT	1
QTY	UoM	DESCRIPTION	ITEM

THIS DRAWING IS A CONTROLLED DOCUMENT.		DWN Z.JAHR 09JUN10	TE Connectivity NAME CABLE ASSEMBLY, IND. USB TO IND. USB TYPE A	
DIMENSIONS: mm		CHK R.HOSSAINI 09JUN10		
		APVD G.LINDEMANN 09JUN10		
TOLERANCES UNLESS OTHERWISE SPECIFIED:		PRODUCT SPEC		
MATERIAL		FINISH	APPLICATION SPEC	RESTRICTED TO
-		-	WEIGHT	-
			SIZE	CAGE CODE
			A3	00779
			DRAWING NO	C-2083112
			SCALE	NTS
			SHEET	1 OF 1
			REV	A1
			CUSTOMER DRAWING	