

SMA FEMALE-SSMA FEMALE STRAIGHT ADAPTER

R191.349.000

Série : ADAPT

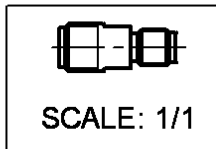
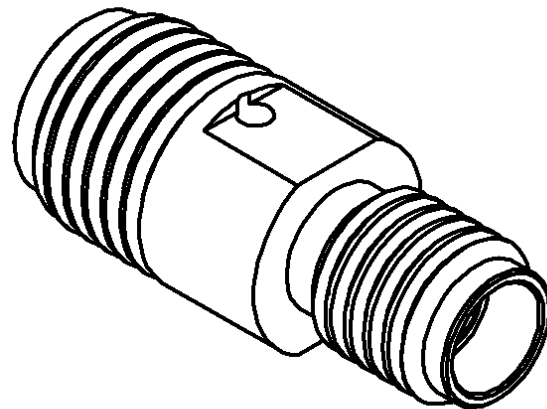
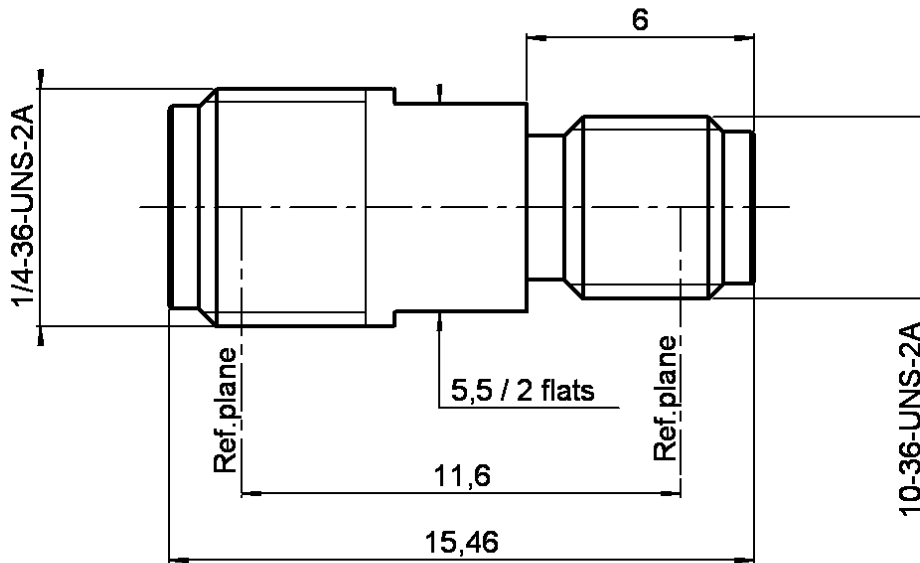

All dimensions are in mm.



COMPONENTS	MATERIALS	PLATINGS (µm)
BODY	BERYLLIUM COPPER	GOLD 0.5 OVER NICKEL 2
CENTER CONTACT	BERYLLIUM COPPER	GOLD 2.5 OVER NICKEL 2
OUTER CONTACT	-	-
INSULATOR	PTFE	-
GASKET	-	-
OTHERS PARTS	-	-
-	-	-
-	-	-

Issue : 0204 C

In the effort to improve our products, we reserve the rights to make changes judged to be necessary.



SMA FEMALE-SSMA FEMALE STRAIGHT ADAPTER

R191.349.000

Série : ADAPT

PACKAGING

SPECIFICATION

Standard	Unit	Other
1		Contact us

ELECTRICAL CHARACTERISTICS

ENVIRONMENTAL

Impedance		50 Ω
Frequency		0-18 GHz
VSWR	1.06 +	0.015 x F(GHz) Maxi
Insertion loss		0.09 √F(GHz) dB Maxi
RF leakage	- (90 - F(GHz)) dB Maxi
Voltage rating		250 Veff Maxi
Dielectric withstanding voltage		750 Veff mini
Insulation resistance		1000 MΩ mini

Operating	-65/+105 °C
Hermetic seal	NA Atm.cm3/s
Panel leakage	NA

MECHANICAL CHARACTERISTICS

OTHERS CHARACTERISTICS

Center contact retention		
Axial force – Mating end		27 N mini
Axial force – Opposite end		27 N mini
Torque		2.8 N.cm mini
Recommended torque		
Mating	SMA	0 N.cm
	SSMA	0 N.cm
	-	0 N.cm
Panel nut		NA N.cm
Mating life		500 Cycles mini
Weight		1.720 g

Issue : 0204 C

In the effort to improve our products, we reserve the rights to make changes judged to be necessary.

