

FEATURES

- Low Noise: -134.8dBu (1nV/√Hz) EIN@60dB gain
- Low THD+N: 0.0003% @ 3 - 30 dB gain
0.0005% @ 40 dB gain
- Low Current: 7.9 mA typ
- Wide Bandwidth: 2.7MHz @40dB gain
- High Slew Rate: 53 V/μs
- Wide Output Swing: +29.8 dBu (±18V supplies)
- Gain adjustable from 0 to >60 dB
- Differential output
- Small 4 x 4mm QFN16 package
- Mates with THAT's family of Digital Preamplifier Controller ICs

APPLICATIONS

- Microphone Preamplifiers
- Digitally-Controlled Microphone Preamplifiers
- Differential Low-Noise Preamplifiers
- Differential Summing Amplifiers
- Differential Variable-Gain Amplifiers
- Moving-Coil Transducer Amplifiers
- Line Input Stages
- Audio
- Sonar
- Instrumentation

Description

The THAT1580 is a versatile, high performance current-feedback amplifier suitable for differential microphone preamp and bus summing applications. The IC comes in a small 4 x 4 mm QFN package, which saves PCB space over discrete and other integrated solutions.

Gain is adjusted via three external resistors (R_A , R_B , and R_G), making it possible to optimize noise over a wide range of gains. The 1580 supports the traditional approach to gain control (viz., THAT's 1510 or 1512) by fixing R_A and R_B , and varying R_G to control gain. However, the 1580 also supports varying all three resistors simultaneously with a dual-gang potentiometer or a switched resistor network. This flexible approach enables the designer to optimize noise over a

wider range of gains than is possible with fixed R_A and R_B .

The 1580's differential output simplifies connection to differential input devices such as A/D converters. The part operates from as little as ±5V up through ±18V supplies. Running on ±18V supplies, at unity gain, the part accepts >+28.3 dBu input signals and will deliver up to +29.8 dBu (differential) output signals.

The 1580 is designed to mate perfectly with THAT's series of Digital Preamplifier Controller ICs.

Designed from the ground up in a high-voltage BiCMOS process, the 1580 improves on existing integrated microphone preamps by offering more versatile gain configuration, lower noise at low gains, higher slew rate, and lower distortion.

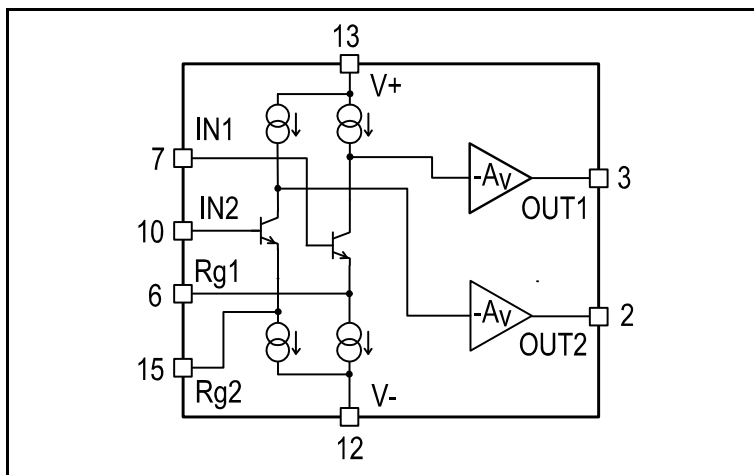

Figure 1. THAT1580 Block Diagram.

Pin Name	QFN Pin
N/C*	1
OUT2	2
OUT1	3
N/C*	4
N/C*	5
Rg1	6
IN1	7
N/C*	8
N/C*	9
IN2	10
N/C*	11
V-	12
V+	13
N/C*	14
Rg2	15
N/C*	16
V-	Thermal Pad

Table 1. Pin Assignments

* N/C pins should be left open and not connect to other traces on the PCB.

SPECIFICATIONS^{1,2}**Absolute Maximum Ratings³**

Supply Voltage (V+) - (V-)	40 V	Operating Temperature Range (T _{OP})	-40 to +85 °C
Maximum Input Voltage (V _{IMAX})	V+ to V-	Output Short-Circuit Duration (t _{SH})	Continuous
Storage Temperature Range (T _{STG})	-40 to +125 °C	Junction Temperature (T _{JMAX})	+125 °C

Electrical Characteristics^{4,5}

Parameter	Symbol	Conditions	Min	Typ	Max	Units
Power Supply						
Supply Voltage	V+; - V-	Referenced to GND	5	—	18	V
Supply Current	I+; -(I-)	No Signal	—	7.9	10	mA
Input Characteristics						
Input Bias Current	I _B	No signal; either input connected to GND	—	6.8	11	μA
Input Offset Current	I _{B-OFF}	No signal;	-1.1	—	+1.1	μA
Differential Input Offset Voltage	V _{OS}	No signal, Inputs connected to GND				
		0 dB gain	-15	—	+15	mV
		+60 dB gain	-450	—	+450	μV
Input Common Mode Voltage Range	V _{IN-CM}	Common Mode	(V-) + 3.7	—	(V+) - 3.2	V
Maximum Differential Input Level	V _{IN-BAL}	R _G = ∞	—	26	—	dBu
Output Characteristics						
Total Differential Output Offset		G = gain	-(15+0.45*G)	—	(15+0.45*G)	mV
Common Mode Output Voltage	V _{OSCM}	No signal; IN1, IN2 connected to GND	—	-640	—	mV
Maximum Single Output Voltage	V _{OUT-SINGLE}	R _L = 2 kΩ	—	(V+) -1, (V-) +1	—	V
Differential Short Circuit Current	I _{SC}	Cold Start; R _L = 0 Ω	—	± 62	—	mA
Maximum Capacitive Load	C _{L MAX}	Over entire temperature range	—	—	100	pF
Maximum Differential Output Level	V _{OUT}	R _L = 2 kΩ	28	—	—	dBu
AC Characteristics						
Gain Equation	G _{DIFF}	Differential in to differential out See Figure 3. (R _G = R _{GV} + R _{GF})			1 + [(R _A + R _B)/R _G]	
Feedback Impedance	R _A , R _B		2	—	—	kΩ
Differential Gain	G _{DIFF}	Programmed by R _A , R _B , R _G	0	—	70	dB
Power Supply Rejection Ratio	PSRR	V+ = -(V-); ±5V to ±18V				
		0 dB gain	—	111	—	dB
		20 dB gain	—	122	—	dB
		40 dB gain	—	147	—	dB
		60 dB gain	—	147	—	dB

1. All specifications are subject to change without notice.

2. Unless otherwise noted, T_A=25°C, V+ = +15V, V- = -15V.

3. Stresses above those listed under "Absolute Maximum Ratings" may cause permanent damage to the device. These are stress ratings only; the functional operation of the device at these or any other conditions above those indicated in the operational sections of this specification is not implied. Exposure to absolute maximum rating conditions for extended periods may affect device reliability.

4. 0 dBu = 0.775 V_{rms}

5. Unless otherwise noted, R_A = R_B = 2.21 kΩ; C_L = 10 pF

Electrical Characteristics (con't) ^{1,3,4,5}							
Parameter	Symbol	Conditions	Min	Typ	Max	Units	
AC Characteristics (continued)							
Bandwidth -3dB	f_{-3dB}	Small signal					
		0 dB gain	—	7.3	—	MHz	
		20 dB gain	—	6.1	—	MHz	
		40 dB gain	—	2.7	—	MHz	
		60 dB gain	—	356	—	kHz	
		Small signal; $R_G = \infty$					
		$R_A = R_B = 2\text{ k}\Omega$	—	8	—	MHz	
$R_A = R_B = 5\text{ k}\Omega$	—	3	—	MHz			
$R_A = R_B = 10\text{ k}\Omega$	—	1.3	—	MHz			
Slew Rate	SR	$V_{OUT} = 50.3V_{P-P}$; $R_L = 2\text{ k}\Omega$; $C_L = 100\text{ pF}$ All gains	31	53	—	V/ μ s	
Total Harmonic Distortion	THD + N	$V_{OUT} = 5V_{RMS}$; $f = 1\text{ kHz}$; $BW = 22\text{ kHz}$					
		0 dB gain	—	0.0004	—	%	
		6 dB gain	—	0.0003	—	%	
		20 dB gain	—	0.0003	—	%	
		40 dB gain	—	0.0005	—	%	
60 dB gain	—	0.005	—	%			
Equivalent Input Noise Voltage	e_N	Inputs connected to GND; $f = 1\text{ kHz}$					
		0 dB gain	—	18.3	—	nV/ $\sqrt{\text{Hz}}$	
		6 dB gain	—	10.1	—	nV/ $\sqrt{\text{Hz}}$	
		20 dB gain	—	3.3	—	nV/ $\sqrt{\text{Hz}}$	
		40 dB gain	—	1.4	—	nV/ $\sqrt{\text{Hz}}$	
	60 dB gain	—	1	—	nV/ $\sqrt{\text{Hz}}$		
	e_N	Inputs connected to GND; $BW = 22\text{ kHz}$; 60 dB gain					
		A-weighted	—	-134.4	—	dBu	
A-weighted		—	-136.6	—	dBu		
e_N	$R_s = 150\Omega$; $BW = 22\text{ kHz}$; 60 dB gain						
	A-weighted	—	-127.8	—	dBu		
			—	-130.0	—	dBu	
Equivalent Input Noise Current	i_N	$f = 1\text{ kHz}$; 60 dB gain	—	1.5	—	pA/ $\sqrt{\text{Hz}}$	
Noise Figure	NF	60 dB gain; $R_s = 150\ \Omega$	—	1.5	—	dB	

Applications

Gain Setting

Three external resistors (R_A , R_B , and R_G) set the gain of the THAT1580. Gain follows the formula:

$A_V = 1 + \frac{R_A + R_B}{R_G}$; where A_V is the (differential) voltage gain of the part (See Figure 2).

Because all three resistors are external, the designer is free to select them for best noise performance at the desired gain setting(s). Note, however, that as with any current-feedback amplifier, the part's bandwidth will vary with $R_{A(B)}$. The 1580 is stable with $R_{A(B)}$ values of 2k Ω or larger; bandwidth decreases with increasing $R_{A(B)}$.

The part's minimum gain is unity (0dB). This occurs with R_G open. Maximum gain depends on the required bandwidth. Full audio bandwidth is maintained to beyond 60dB gain.

Other integrated mic preamps which include internal resistors for R_A and R_B (e.g., the THAT 1510 and 1512) allow gain to be varied using one single-gang potentiometer. The 1580 offers a similar hookup, by fixing R_A and R_B and varying R_G . This is shown in the circuit of Figure 3, where R_G is made up of fixed (R_{GF}) and variable (R_{GV}) portions. In such applications, designers should take care in specifying the pot's element construction to avoid excess noise.

The potentiometer taper will set the circuit's characteristic of gain vs. pot rotation. Typically, reverse log (audio) taper elements offer the desired behavior in which gain increases with clockwise rotation (and lower values for R_{GV}).

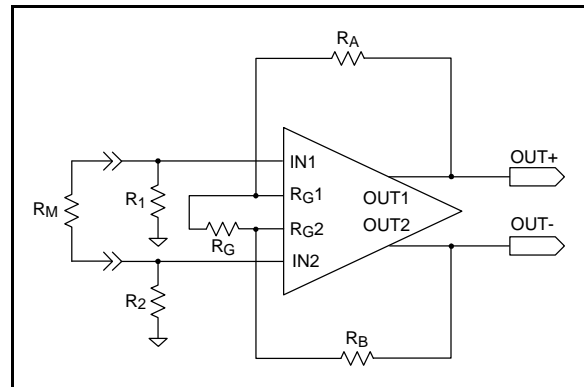

Figure 2. Simple THAT1580 Amplifier Circuit

Overall gain accuracy depends on the tolerance of the resistors, including especially the pot (R_{GV}) which dominates R_G . Theoretically, when R_{GV} is zero, the gain is determined by R_A , R_B , R_{GF} alone. End resistance ("hop off") will alter the actual gain; reducing R_{GF} by the amount of end resistance may be appropriate, especially if the end resistance is consistent. It will be easier to maintain consistent gain at the high-gain end of the pot travel at higher values for R_A and R_B , since this makes the value of R_G required proportionately larger for any given gain. The circuit of Figure 3 shows 5 k Ω resistors for R_A and R_B , so for 60 dB gain, $R_G = 10 \Omega$. Its noise performance is very good at 60 dB gain ($EIN = 1.1 \text{ nV}/\sqrt{\text{Hz}}$, or -133.9 dBu⁶ with a zero ohm input termination, and 1.92 nV/ $\sqrt{\text{Hz}}$, or -129.1 dBu⁶ with a more realistic 150 Ω input termination). At minimum gain (6 dB) its noise

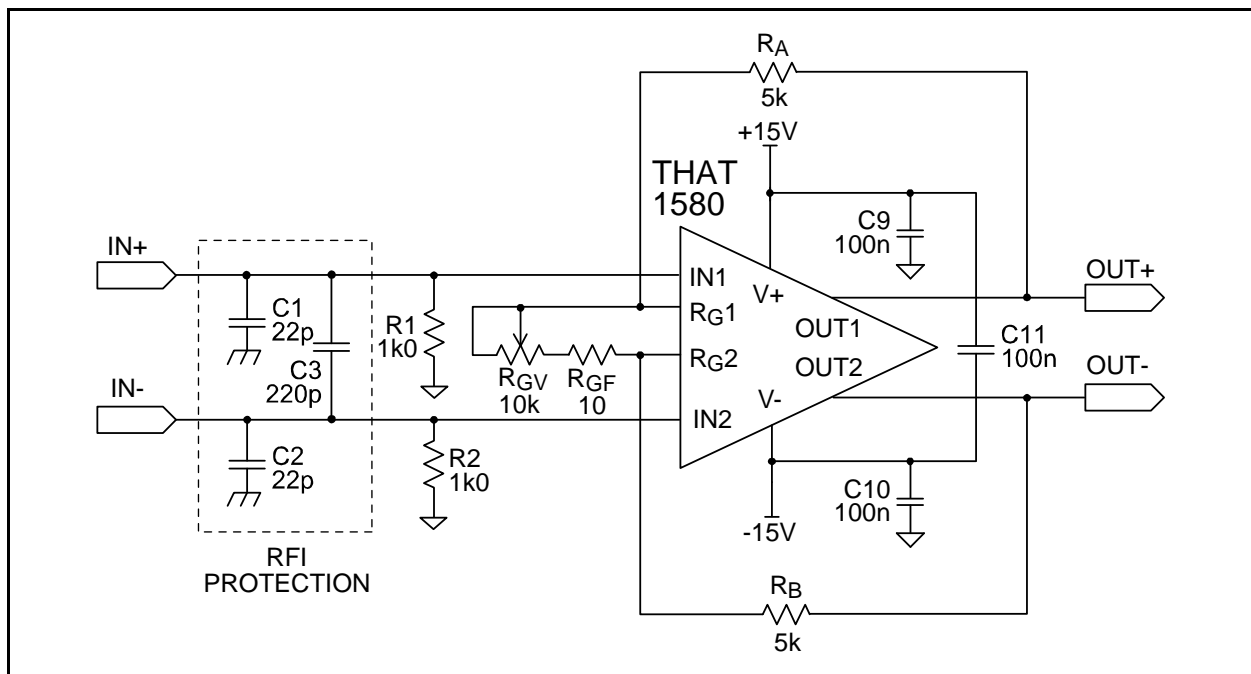

Figure 3. 1580 Typical Application Circuit Using Single-Gang Pot for Gain Control.

performance is still good ($EIN = 19.9 \text{ nV}/\sqrt{\text{Hz}}$), or -108.8 dBu^6 with a zero ohm input termination.

One disadvantage of the circuit of Figure 3 is that differential dc offset at the 1580 output will vary with gain. At 0 dB gain, the 1580's worst-case differential output offset voltage is $\sim 15 \text{ mV}$, while at 60dB gain, this is $\sim 465 \text{ mV}$. As well, if the wiper of the pot loses contact with the element, gain will abruptly change to unity, with an attendant change in dc offset as well. To minimize dc offsets, THAT recommends the circuits of Figures 6 and 8, which ac couple R_G .

Improving Noise Performance

The 1580 has extremely low input voltage noise. To achieve this feature, the input transistors are large-geometry NPN types, biased at high ($\sim 1 \text{ mA}$) collector current. In order to maintain the low voltage-noise performance of the 1580, designers should take care not to present too high a source impedance to the input pins. A high impedance generates its own self-noise when not shunted by the impedance of the source connected to the input pins.

Additionally, the input transistors' base current, and any noise in that base current, must be drawn through the bias network (R_1 and R_2 in Figure 3) connected to IN1 and IN2 (which connect to the bases of the input transistors). Any input current noise will be drawn across the source impedance (as seen by the inputs), which turns it into a voltage that is amplified by the gain of the device. Too high a source impedance can easily spoil the noise of the device. The $1\text{k}\Omega$ resistors used at R_1 and R_2 in

Figure 9 provide a low source impedance for the 1580 even when the input is open, and provide a $2 \text{ k}\Omega$ (differential) load for the microphone. Higher source impedances will increase noise seen (and heard!) with open inputs.

One disadvantage of the single-pot approach is that noise at low gains is dominated by the noise of resistors R_A and R_B . For the circuit of Figure 3, the equivalent input noise at 6 dB gain (the minimum pot setting) is $\sim 19.9 \text{ nV}/\sqrt{\text{Hz}}$, or -108.8 dBu^7 . Much lower noise ($\sim 11.2 \text{ nV}/\sqrt{\text{Hz}}$, or -113.8 dBu^6) can be achieved if R_A and R_B are reduced to $\sim 2.5 \text{ k}\Omega$, but to achieve 60 dB gain, this requires R_G to be $= 5 \Omega$. (This analysis also assumes $R_{GV} = 5 \text{ k}\Omega$.)

An alternative offered by the 1580 (and not by preamps with internal R_A and R_B) is that all three resistors may be varied at once. See the circuit of Figure 4, which uses a dual-gang potentiometer as the variable element.

In Figure 4, high gain occurs by decreasing R_G while simultaneously increasing R_A and R_B . An advantage of this approach is that R_A and R_B will naturally be lower for low gains, without requiring such a low value for R_G to achieve high gains. In this circuit, 60 dB gain occurs with $R_G = 8.66 \Omega$, and EIN is $1.1 \text{ nV}/\sqrt{\text{Hz}}$, or -133.9 dBu^6 with a zero ohm input termination. With a 150Ω input termination, the EIN , dominated by the 150Ω resistor, is $1.92 \text{ nV}/\sqrt{\text{Hz}}$ or $\sim -129.1 \text{ dBu}^7$.

This circuit's minimum gain is 3dB, where R_{GV} is fully CCW. At this gain, the input-referred noise is

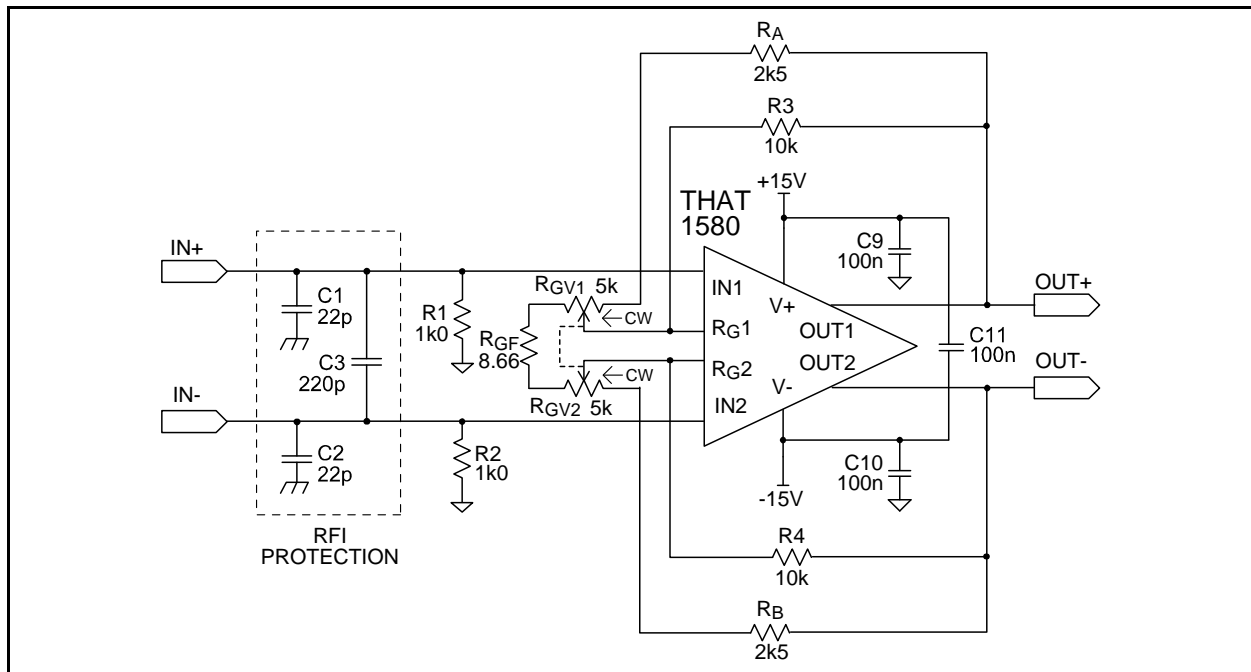

Figure 4. 1580 Typical Application Circuit Using Dual-Gang Pot for Gain Control.

⁶ All audio-band noise calculations assume a 20 Hz to 20 kHz bandwidth with no weighting.

⁷ 20 kHz bandwidth, unweighted. Noise figures will generally be 2.2 dB better (lower) with A weighting.

~12.1 nV/ $\sqrt{\text{Hz}}$, or -113.1 dBu⁶ with a shorted input, and is essentially the same with a 150 Ω input termination. This is about 4.3 dB better than the circuit of Figure 3 at its minimum gain (6 dB). Note also that at the minimum +3 dB gain and ± 18 V rails, the circuit of Figure 4 can accept up to +26.8 dBu input signals without clipping. This offers more headroom than the circuit of Figure 3, which has a maximum input of +23.8 dBu with the same rails.

Of course, other minimum and maximum gains can be accommodated by varying the resistors at R_A , R_B , R_{GV} , and R_{GF} . One additional advantage of the dual-gang pot approach is that it allows more even distribution of gain versus pot rotation. See "De-Integrating IC Preamps", available on THAT's web site.

For variable-gain applications where gain accuracy is important, THAT recommends using discrete, switched resistors for R_A , R_B and R_G . With switched resistors, it becomes even easier to vary all three resistors to optimize noise.

As with the circuit of Figure 3, R_G in Figure 4 is dc coupled. This means that the differential output offset voltage will vary with gain. Also, if the wiper of either half of the gain pot loses contact with the element, gain and output offset will change abruptly. R_3 and R_4 help this situation by minimizing the change in dc offset generated by the 1580's input bias current (drawn across the combination of R_3 in parallel with the series combination of R_A and part of R_{GV} , or the other mirror half). Again, for best dc performance, THAT recommends the circuits of Figures 7 and 8 which ac-couple R_G .

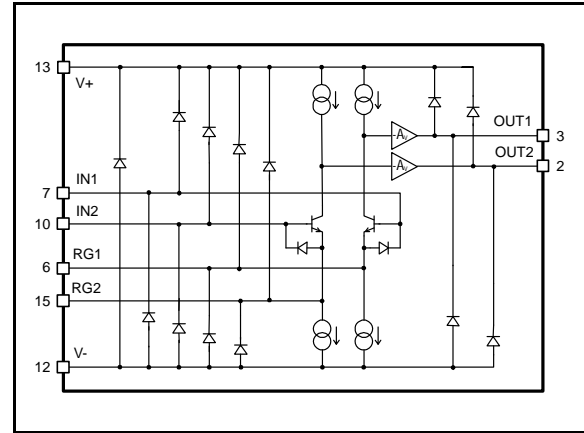

Figure 5. 1580 Equivalent Circuit with Internal Protection Diodes.

DC Offsets and CG

Because R_G is dc coupled in the circuits of Figure 3 and 4, the differential dc level at the output of the 1580 will vary with gain. In most such applications, the output should be ac-coupled to the next stage, in order to eliminate this varying offset.

For applications where gain is variable, THAT recommends that R_G be ac-coupled as shown in Figures 6 and 7. (Figure 6 corresponds to Figure 3, while Figure 7 corresponds to Figure 4.) By adding C_G in series with R_G , dc gain is fixed at unity. This constrains the differential output dc offset to just over ± 15 mV, and, more importantly, C_G prevents the offset from varying with gain.

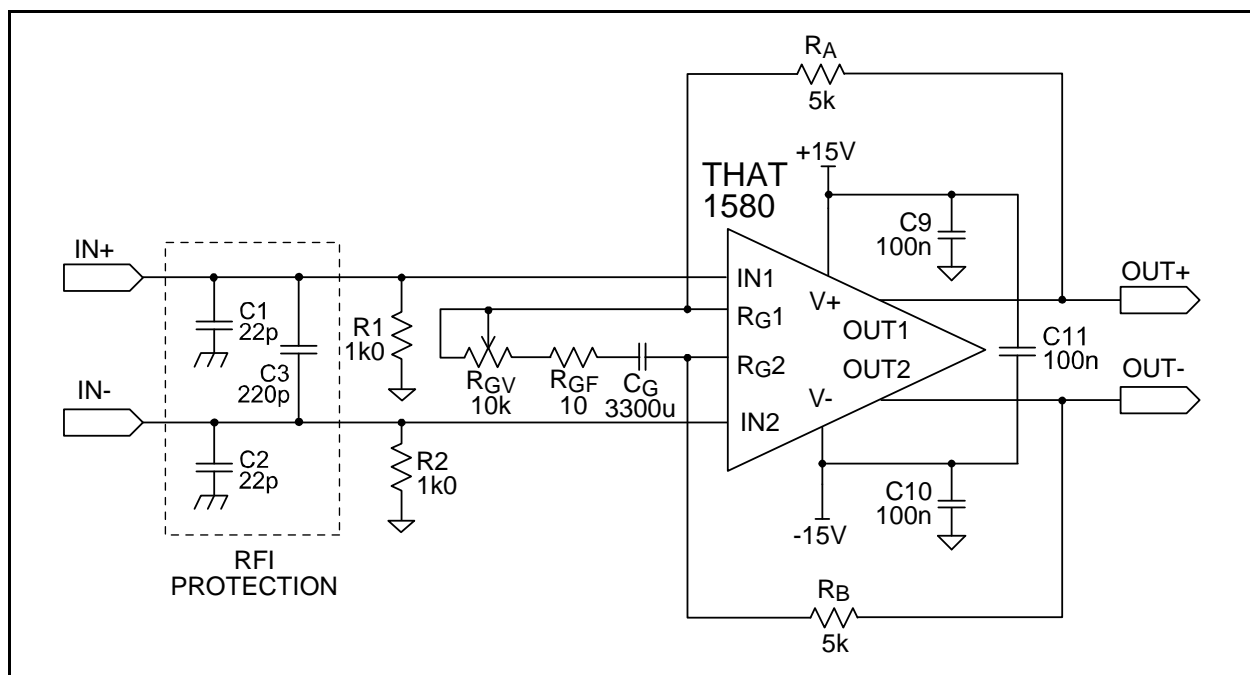

Figure 6. 1580 Typical Application Circuit With Single-Gang Pot for Gain Control, AC-Coupled R_G .

C_G must be large enough not to interfere with low-frequency response at the smallest values of R_G . With the values shown in Figures 6 and 7, the -3 dB corner is about 5 Hz. Both circuits require a C_G of 3,300 μ F to maintain this low-frequency corner.

The dc voltage appearing across C_G is very small and equal to the 1580's "60dB Differential Input Offset Voltage", specified at 450 μ V, maximum. The polarity of this voltage across C_G will be completely random. While the manufacturer of the capacitor to be used will have the last word on the subject, THAT understands that most polarized electrolytic types can tolerate at least 1V of continuous reverse voltage with no impact on performance or reliability. We recommend a 6.3V aluminum electrolytic for minimum PCB footprint.

Note, in applications where very low frequency signals at high levels may be present at the input of the preamp, the low frequency will appear across C_G , attenuated by the filter composed of R_G and C_G . However, THAT does not believe this is a significant consideration for most audio applications.

Inputs

Simple Configurations

As shown in Figure 5, the 1580 includes protection diodes at all pins. These diodes reduce the likelihood that accidental electrostatic discharge (ESD) or electrical over stress (EOS) will damage the ICs. Other diodes across the base-emitter junctions of the input transistors prevent excessive reverse biasing of these junctions (which would degrade the noise performance of the input devices).

However, while the internal diodes are effective against ESD, they should not be relied upon to

protect against excessive input voltage, which can result in significant current flow. This is a particular problem when the preamplifier includes a source of +48 V phantom power (see text below) but can be of concern in any situation where the input may be connected to high signal levels, in which the input signal voltage could exceed the supply rails. The phantom power protection networks shown in Figures 8 and 9 are worth considering even if phantom power is not included in the design.

Phantom Power

Phantom power is required for many condenser microphones. THAT recommends the circuits of Figure 8 and 9 when phantom power is included. R_3 , R_4 , and $D_1 \sim D_6$ are used to limit the current that flows through the 1580 inputs when overloaded. These also protect the 1580 when the circuit inputs (IN+ and IN-) are shorted to ground while phantom power is turned on. This causes C_4 and/or C_5 to discharge through other circuit components (including the 1580 inputs), often generating transient currents of several amps. R_3 and R_4 should be at least 10 Ω to limit destructive currents. (Higher values further limit current flow, but introduce additional source impedance and noise.) Take care to ensure that the resistors used can handle the short-term inrush current; many small surface-mount types cannot. With the values shown for C_4 and C_5 , THAT recommends at least 1/4 W resistors.

D_1 through D_4 prevent the IC's inputs from significantly exceeding the supply rails. For best results, they should be glass-passivated types (sometimes called "GP") to ensure low leakage. (Leakage manifests itself as noise in addition to offset.) D_5 and D_6 steer currents around the input stage in the 1580, further preventing damage.

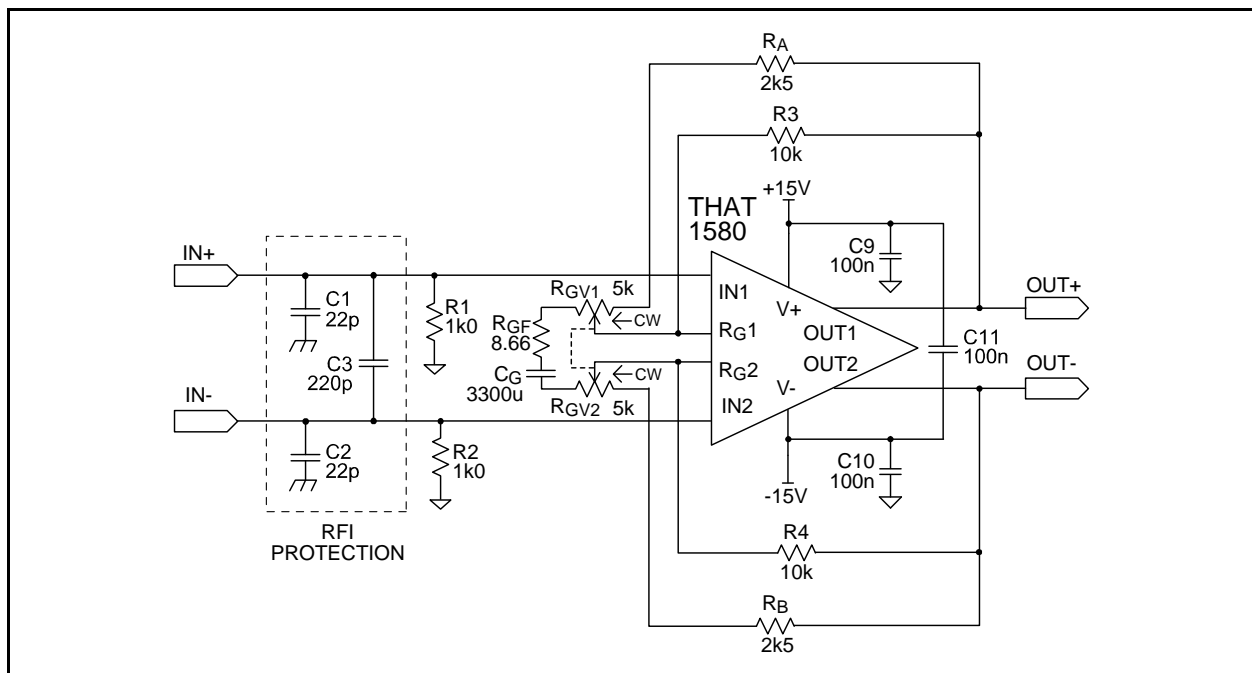

Figure 7. 1580 Typical Application Circuit With Dual-Gang Pot for Gain Control, AC-Coupled R_G .

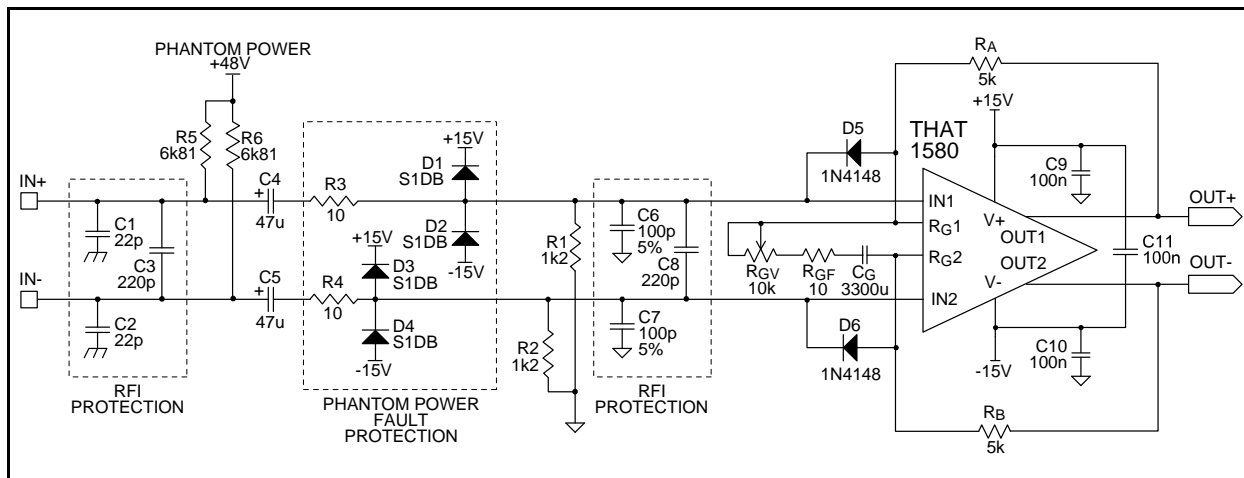

Figure 8. 1580 Typical Phantom Power Application Circuit With Single-Gang Pot for Gain Control, AC-Coupled R_G.

The series combination of C₄ and C₅ should be made large to minimize high-pass filtering of the signal based upon the sum of the values of R₁+R₂. As well, keeping their reactance low relative to the external microphone's source impedance will avoid increasing the effects of low-frequency current noise in the 1580 input stage.

As in Figures 3 and 4, Figures 8 and 9 differ in their approach to the gain potentiometer. The single-gang pot shown in Figure 8 may be a little less expensive to implement, but the dual-gang pot of Figure 9 will deliver better noise performance at low gains, for the reasons noted above. Note that Figure 9 features minimum gain of 3 dB, compared to Figure 8 at 6 dB. The low-frequency corners are about the same (~5 Hz) in the two circuits.

Other manufacturers have recommended, and some pro audio products include, a zener diode arrangement instead of the bridge rectifier to V₊ and V₋ as shown in Figures 8 and 9. THAT does not

recommend the zener approach, because we find that R₃ and R₄ must be made much larger (e.g., 51 Ω) in order to limit peak currents enough to protect reasonably sized zener diodes (e.g. 1/2 W). Such large series input resistors will limit the noise performance of the preamp. The ultimate floor is set by the impedance of the microphone, but any additional series resistance further degrades performance.

Additionally, while at one time we recommended Schottky diodes for D₁~D₄ in Figures 8 and 9, we no longer do so. Schottky diodes appeal because of their fast turn-on behavior and low forward voltage drop. However, aside from their higher cost, our experience is that they tend to leak much more than conventional, glass-passivated power diodes, and that their fast turn-on behavior is unnecessary in practice.

For further insights into this subject, see the Audio Engineering Society preprint "The 48 Volt

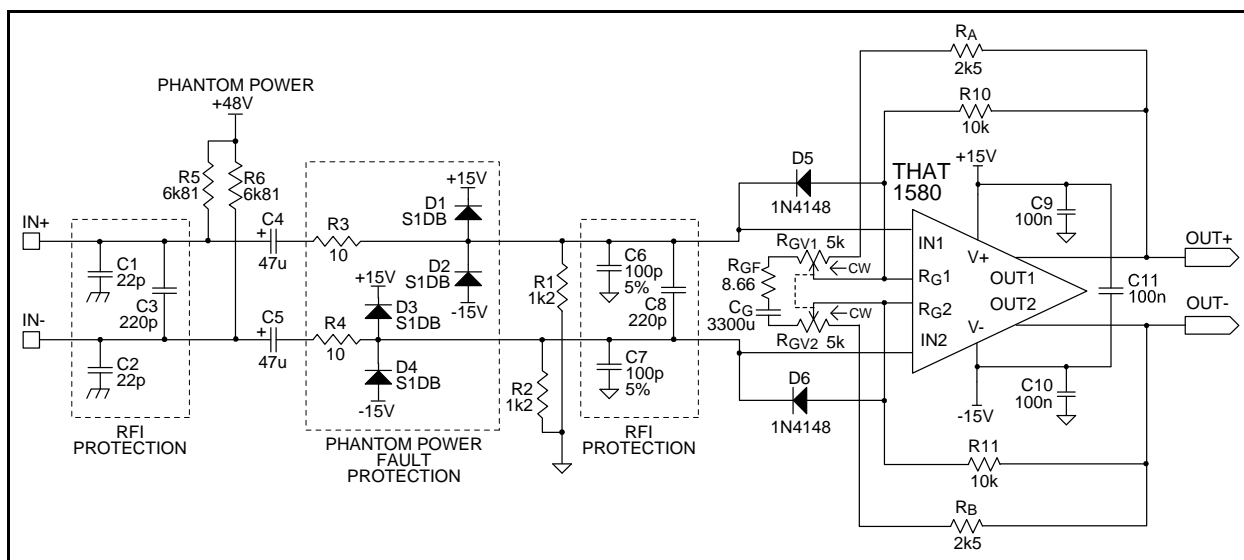

Figure 9. 1580 Typical Phantom Power Application Circuit With Dual-Gang Pot for Gain Control, AC-Coupled R_G.

Phantom Menace Returns” by Rosalfonso Bortoni and Wayne Kirkwood, presented at the 127th AES Convention, (available on THAT’s web site) and subsequently published in the Journal of the Audio Engineering Society.

Outputs

Each of the two 1580 outputs has a dc offset of -640 mV. This common-mode dc offset must be considered in connecting the 1580 to subsequent circuitry. Most high-performance A/D converters require a specific dc common-mode voltage at their inputs for proper operation. In such cases, drive circuitry should be configured to add the appropriate dc voltage to the 1580 outputs in order to match the converter.

As well, the 1580 has common-mode gain of unity, regardless of its differential gain. Common-mode inputs are presented at the output, along with the common-mode dc offset of -640 mV. If these common-mode signals are not removed, they may limit the dynamic range of subsequent stages.

If a single-ended output is desired, the THAT1246 is a self-contained differential amplifier which offers a convenient way to remove common mode offset, convert to single-ended, and match the headroom of the 1580 output to a single-ended drive. A dual version of this part, the 1280, and low cost versions (1250 single and 1290 dual) are also available. See Design Note 140, “Input and Output Circuits for THAT Preamplifier ICs” for further ideas.

The 1580 will drive loads as low as 2 k Ω , making it possible to drive A/D converters through resistive

attenuators in low-cost applications. However, in order to provide common mode rejection and to improve distortion performance, THAT recommends active designs to drive high-performance A/D converters.

Digitally Controlled Gain

In addition to analog-controlled applications, the 1580 has been designed to mate perfectly with THAT’s family of Digital Preamplifier Controller ICs to produce an optimized, digitally controlled audio preamplifier. THAT’s digital controllers are intended primarily for use in the feedback loop of differential, current-feedback gain stages, such as the 1580.

Figure 10 shows a THAT5171 or 5173 Digital Controller connected to the 1580. The controller varies R_A , R_B and R_G (from Figure 2) to produce the desired gain based on the gain command provided via the SPI control interface. The feedback network impedances in these controller ICs have been chosen to minimize noise and distortion within the combined amplifier and controller at each gain step.

The controllers also include a differential servo amplifier which minimizes the differential dc offset at the output. The servo generates a correction voltage at the 1580 inputs which in turn reduces the output offset voltage. The output dc offset is controlled by the servo amplifier inside the controller, making C_G unnecessary, and enabling a more compact PCB design.

Please refer to the 5171 and 5173 data sheets for more information.

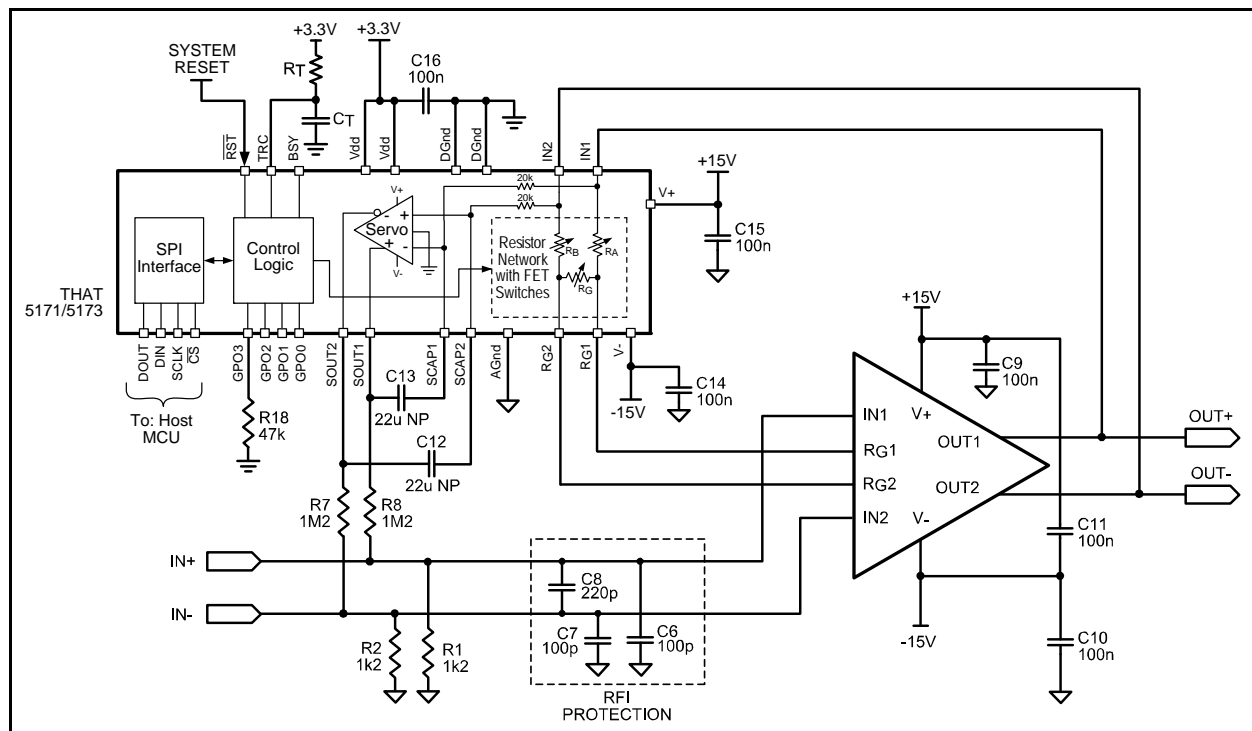

Figure 10. Basic Application Circuit With THAT 5171/5173 Digital Controller.

PCB Layout Information

The 1580 QFN package includes an exposed thermal pad on its bottom, as shown in Figure 11. This pad should be soldered to a thermal pad on the PCB as shown in Figure 12. Five thermal vias should be arranged in the configuration shown to conduct heat from the top layer of the PCB to the bottom layer, which should have a similar- or larger-sized plane. The thermal pad can be left electrically floating. **However if it is not electrically floating, it should be connected only to V-.**

For current feedback amplifiers such as the THAT1580, stray capacitance to ground or power planes results in higher gains at high frequencies. This compromises common-mode rejection at high frequencies and, in extreme cases, can even lead to oscillation. Take care to avoid ground and power planes under and near R_A , R_B , R_G , their associated pins and traces.

The input signal lines are susceptible to magnetic pickup from power supply currents, which often take the form of half-wave rectified versions of the signal. Voltage fluctuations on the supply lines can couple capacitively as well. For this reason, take care not to run power and input signal lines close and/or parallel to each other.

Minimizing RFI

To minimize RF pickup, the $C_1 \sim C_3$ network at the input of all the applications schematics should be located as close as possible to the input connector, and the ground ends of C_1 and C_2 tied as closely as possible to the chassis. When using the additional RFI protection network $C_6 \sim C_8$ (shown in the phantom power circuits Fig. 8 and 9), these components should be located as close as possible to the 1580's input pins, and the grounded ends of this network should connect to the analog circuit ground.

Package and Soldering Information

Package Characteristics						
Parameter	Symbol	Conditions	Min	Typ	Max	Units
Package Style		See Fig. 11 for dimensions		16 Pin QFN		
Thermal Resistance	θ_{JA}	QFN package soldered to board ⁸		130		°C/W
Environmental Regulation Compliance		Complies with July 21, 2011 RoHS 2 requirements				
Soldering Reflow Profile		JEDEC JESD22-A113-D (250 °C)				
Moisture Sensitivity Level		MSL Above-referenced JEDEC soldering profile		3		

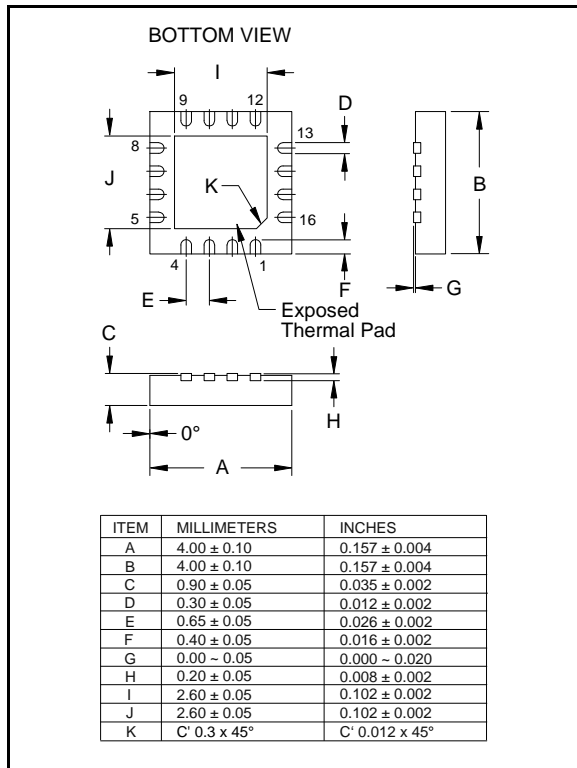

Figure 11. QFN-16 Surface Mount Package.

Package	Order Number
16 pin QFN	1580N16-U

Table 2. Ordering information.

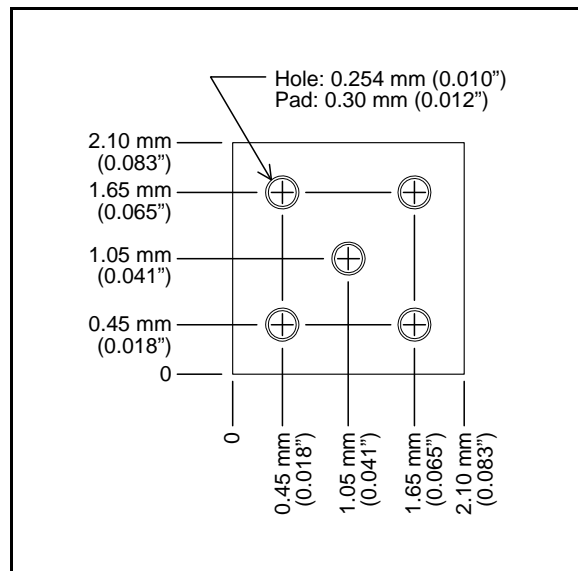

Figure 12. QFN-16 Thermal Solder Pad.

⁸ PCB used for thermal characterization was two-layer board, 2" x 2", with thermal pad on top and bottom as shown in Figure 12.

Revision History

Revision	ECO	Date	Changes	Page
00	—	06/08/15	Initial Release	—