

UNCONTROLLED DOCUMENT

PART NUMBER
SSI-LXR3816SRD15WR

REV.
A

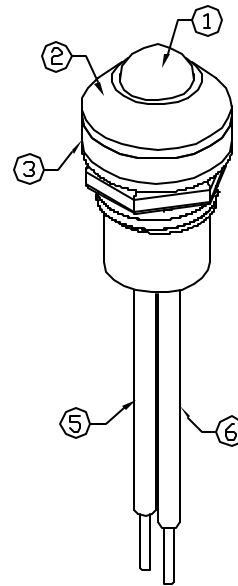
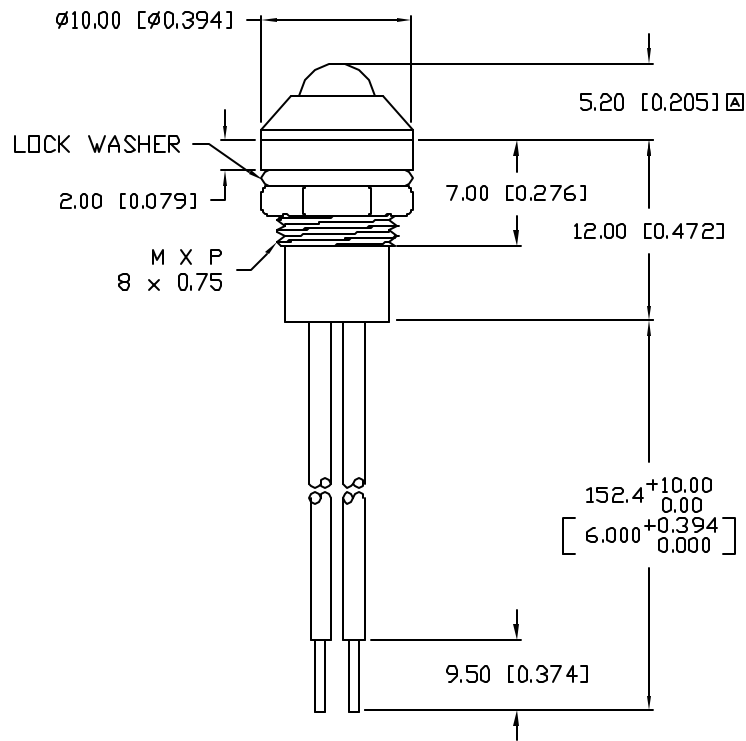

PANEL CUTOUT

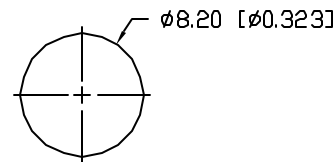

NOTES:

1. SSL-LX5093SRD, RED LED. TRIM TO 4mm.
2. SSI-LXR3816, CHROME HOUSING.
3. LXP-WA-3816, RUBBER GASKET.
4. SSH-LXH4815BSG, BUSHING. INSERT AND CRIMP.
5. ANODE LEAD: LXP-WST24RDT0C, 24 AWG. TINNED OVERCOAT, RED INSULATION, CUT 160mm LONG, STRIP 9.5mm & 3mm.
6. CATHODE LEAD: LXP-WST24BLT0C, 24 AWG. TINNED OVERCOAT, BLACK INSULATION, CUT 160mm LONG, STRIP 9.5mm & 3mm.
7. ASSEMBLE IN ORDER: LED, SILICON, THEN BUSHING.
8. SPLASH RESISTANT PER NEMA SPEC. 250 SECTION 6.7.

ELECTRO-OPTICAL CHARACTERISTICS $T_A=25^\circ\text{C}$ $I_f=20\text{mA}$

PARAMETER	MIN	TYP	MAX	UNITS	TEST COND
PEAK WAVELENGTH		660		nm	
FORWARD VOLTAGE		1.8	2.2	V_f	
REVERSE VOLTAGE	4.0			V_r	$I_f=100\mu\text{A}$
AXIAL INTENSITY		100		mcd	$I_f=20\text{mA}$
VIEWING ANGLE		60		2x theta	
EMITTED COLOR:	RED				
EPOXY LENS FINISH:	RED DIFFUSED				

LIMITS OF SAFE OPERATION AT 25°C

PARAMETER	MAX	UNITS
PEAK FORWARD CURRENT*	150	mA
STEADY CURRENT	30	mA
POWER DISSIPATION	100	mW
DERATE FROM 25°C	-1.2	mW/°C
OPERATING, STORAGE TEMP.	-40 TO +85	°C

* $t < 10\mu\text{s}$

*UNLESS OTHERWISE SPECIFIED TOLERANCES PER DECIMAL PRECISION ARE: X=±1 (±0.039), XX=±0.5 (±0.020), XXX=±0.25 (±0.010), XXXX=±0.127 (±0.005). LEAD SIZE=±0.05 (±0.002), LEAD LENGTH=±0.75 (±0.030), MIN= ^{+0.00}/_{-0.00} DECIMAL PRECISION, MAX= ^{+0.00}/_{-0.00} DECIMAL PRECISION

UNCONTROLLED DOCUMENT

REV.
A

PART NUMBER

SSI-LXR3816SRD15WR

CONFIDENTIAL INFORMATION
THE INFORMATION CONTAINED IN THIS DOCUMENT IS THE PROPERTY OF LUMEX INC. EXCEPT AS SPECIFICALLY AUTHORIZED IN WRITING BY LUMEX INC, THE HOLDER OF THIS DOCUMENT SHALL KEEP ALL INFORMATION CONTAINED HEREIN CONFIDENTIAL AND SHALL PROTECT SAME IN WHOLE OR IN PART FROM DISCLOSURE AND DISSEMINATION TO ALL THIRD PARTIES.



290 E. HELEN ROAD
PALATINE, IL 60067-6976
PHONE: +1.847.359.2790
US WEB: www.lumex.com
TW WEB: www.lumex.com.tw

T-5mm 660nm SUPER RED LED PANEL INDICATOR,
RED DIFFUSED LENS, 6.0" WIRE LEADS, SPLASH PROOF.

RELIABILITY NOTE
OUR MANY YEARS OF EXPERIENCE DATA ACCUMULATION INDICATE THAT SOLDER HEAT IS A MAJOR CAUSE OF EARLY AND FUTURE FAILURE. PLEASE PAY ATTENTION TO YOUR SOLDERING PROCESS.

DRAWN BY:

BC

CHECKED BY:

APPROVED BY:

DATE: 4.30.99

PAGE: 1 OF 1

SCALE: N/A