

| REVISIONS       |             |        |            |
|-----------------|-------------|--------|------------|
| REV             | DESCRIPTION | DATE   | APPROVED   |
| 01 <sub>0</sub> | RELEASED    | 3/6/91 | <i>DRJ</i> |

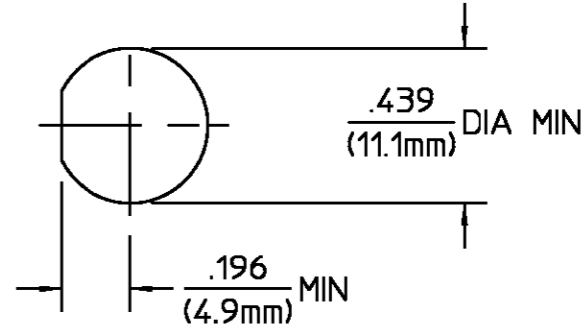

RECOMMENDED MOUNTING HOLE (N.T.S.)

|                                 |                                                            |                                                              |
|---------------------------------|------------------------------------------------------------|--------------------------------------------------------------|
| HOUSING MOUNTING NUT LOCKWASHER | STAINLESS STEEL PER ASTM-A484 AND ASTM-A582, TYPE 303      | PASSIVATE PER ASTM-A380                                      |
| DIELECTRIC                      | TFE FLUOROCARBON PER ASTM-D-1457                           | N/A                                                          |
| CENTER CONTACT                  | BERYLLIUM COPPER PER ASTM B 196, ALLOY C17300, CONDITION H | GOLD PLATE PER MIL-G-45204 OVER COPPER PLATE PER MIL-C-14550 |
| "O" - RING                      | FLOUROCARBON RUBBER PER MIL-R-83248                        | N/A                                                          |

| COMPONENT | MATERIAL | FINISH |
|-----------|----------|--------|
|-----------|----------|--------|

|                                                                                                             |                            |                                                                               |
|-------------------------------------------------------------------------------------------------------------|----------------------------|-------------------------------------------------------------------------------|
| UNLESS OTHERWISE SPECIFIED DIMENSIONS ARE IN INCHES TOLERANCE ON<br>FRAC. DEC. ANGLES<br>± 1/64 ± .005 ± 1° | DRAWN BY M.Y. DATE 2-5-91  | <b>AMP</b><br>AMP Incorporated<br>140 Fourth Avenue<br>Waltham, MA 02451-7599 |
|                                                                                                             | CHECKED BY BB 3/6/91       |                                                                               |
|                                                                                                             | APP'D BY <i>DRJ</i> 3/6/91 |                                                                               |

NOTES:  
1. CAPTURED CENTER CONTACT

|                                                                                                                                                                                                                                   |                    |                                                      |                     |
|-----------------------------------------------------------------------------------------------------------------------------------------------------------------------------------------------------------------------------------|--------------------|------------------------------------------------------|---------------------|
| These drawings and specifications are the property of Omni Spectra Incorporated and shall not be reproduced or copied or used in whole or in part as the basis for the manufacture or sale of item(s) without written permission. | USE ASSY PROCEDURE | TITLE OSM JACK TO OST JACK BULKHEAD FEEDTHRU ADAPTER |                     |
|                                                                                                                                                                                                                                   | NO. AP. N/A        | SIZE B                                               | REV 01 <sub>0</sub> |
|                                                                                                                                                                                                                                   |                    | CODE IDENT NO. 26805                                 | 4184-2240-00        |
|                                                                                                                                                                                                                                   | SCALE 4:1          | SHEET 1 OF 1                                         |                     |