

THIS DRAWING IS UNPUBLISHED. RELEASED FOR PUBLICATION 20
 © COPYRIGHT 20 BY - ALL RIGHTS RESERVED.

LOC	DIST	REVISIONS			
P	LTR	DESCRIPTION	DATE	DWN	APVD
-	-	A	RELEASE	02APR2015	M.S X.X
-	-	AI	UPDATE TABLE	16APR2015	M.S X.X
-	-	B	ECR-16-015004	25OCT2016	M.S X.X
-	-	BI	ECR-17-000249	05JAN2017	M.S X.X

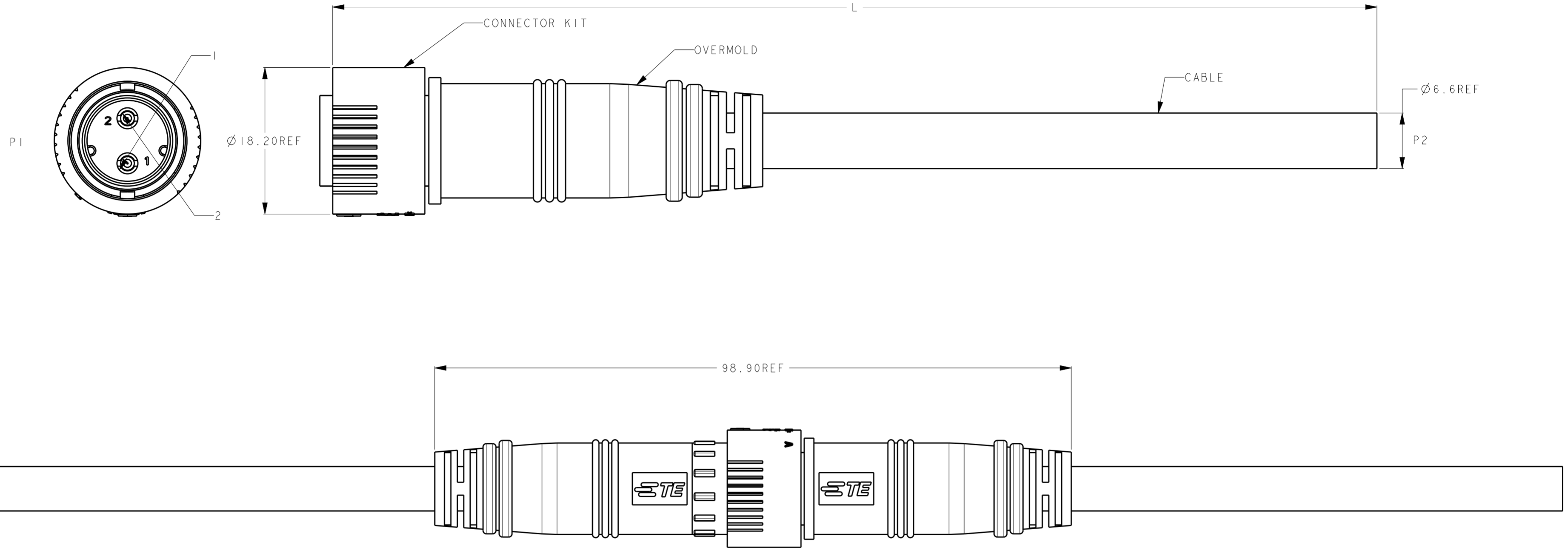

MATES WITH 2834001 SERIES.

NOTES:
 1. MATE WITH 2834001 SERIES.
 2. RATINGS:
 VOLTAGE: 300V AC/DC
 CURRENT: 7A MAX.
 TEMPERATURE: 80°C

WIRING DIAGRAM		
P1	WIRE COLOR	P2
P1-1	WHITE	-
P1-2	BLACK	-

P/N	CABLE	DIM A	L (mm)
9-2834000-1	RUBBER (THERMOPLASTIC ELASTOMER TYPE)	Ø 7.6	150±5
9-2834000-2			250±10
9-2834000-3			500±15
9-2834000-4			1000±15

THIS DRAWING IS A CONTROLLED DOCUMENT.		DWN SHI MING 10SEP2014	TE Connectivity	
DIMENSIONS: mm		CHK SHI MING 10SEP2014		
TOLERANCES UNLESS OTHERWISE SPECIFIED:		APVD XU XIANG 10SEP2014	NAME 2P MALE CABLE ASSEMBLY CIRCULAR LIGHTING SEALED CONN.	
0 PLC ±- 1 PLC ±1.0 2 PLC ±0.5 3 PLC ±- 4 PLC ±- ANGLES ±- FINISH		PRODUCT SPEC 108-137041	SIZE A2	
MATERIAL -		APPLICATION SPEC 114-137041	CAGE CODE -	DRAWING NO C-2834000
		WEIGHT -	RESTRICTED TO -	SCALE NTS
		Customer Drawing	SHEET 1 OF 2	REV BI

THIS DRAWING IS UNPUBLISHED. RELEASED FOR PUBLICATION 20
 © COPYRIGHT 20 BY - ALL RIGHTS RESERVED.

LOC		DIST		REVISIONS			
P	LTR	DESCRIPTION	DATE	DWN	APVD		
-	-	SEE SHEET 1	-	-	-		

1. PUT PIECES OF PARTS INTO THE PLASTIC BAG, AND SEALED WITH RUBBER BAND AS 1 BUNCH.

3. SEAL THE CARTON.

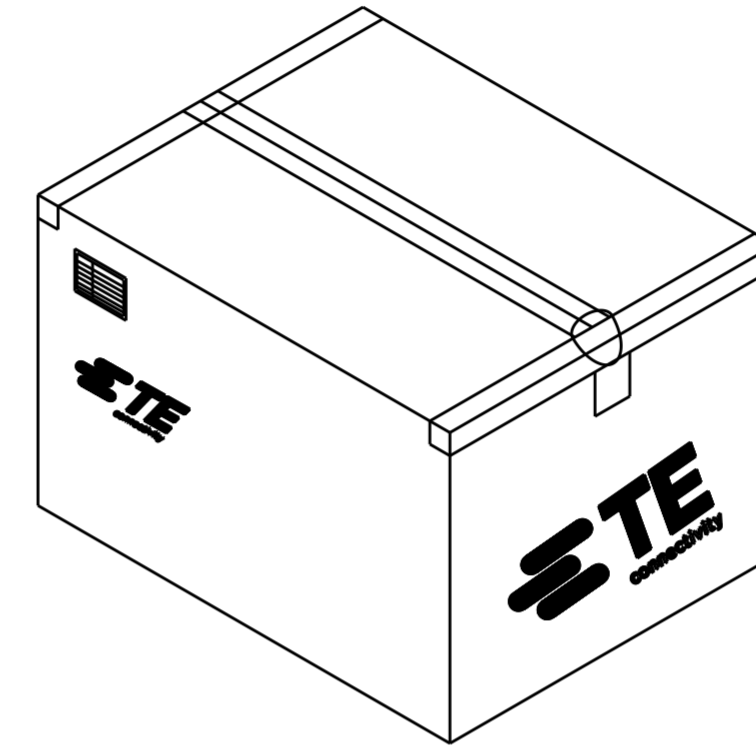
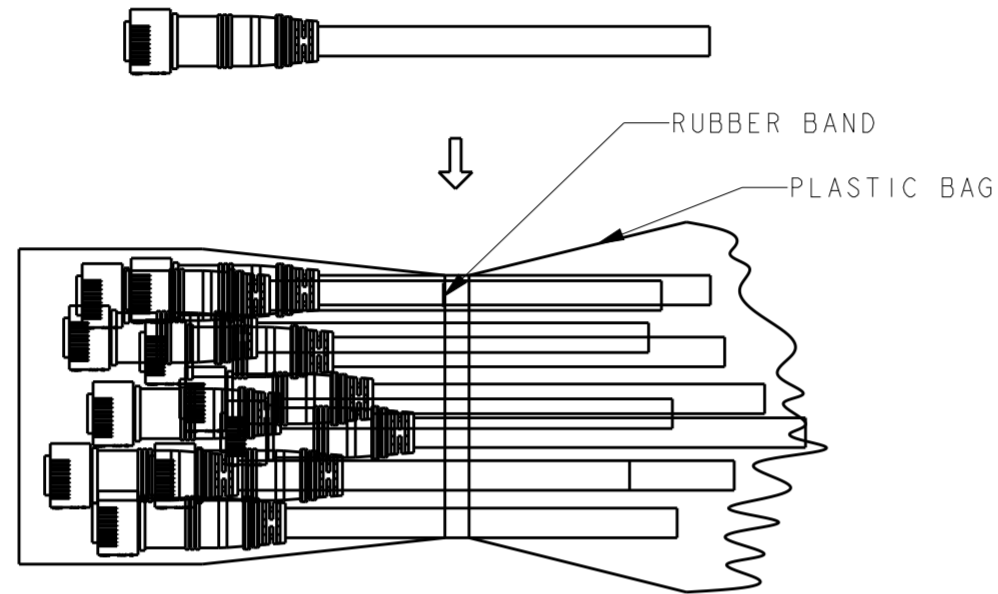

2. PUT BUNCHES OF PARTS INTO CARTON.

4. PACKAGING QUANTITIES(REFER SHEET 1 FOR PN DEFINITION):

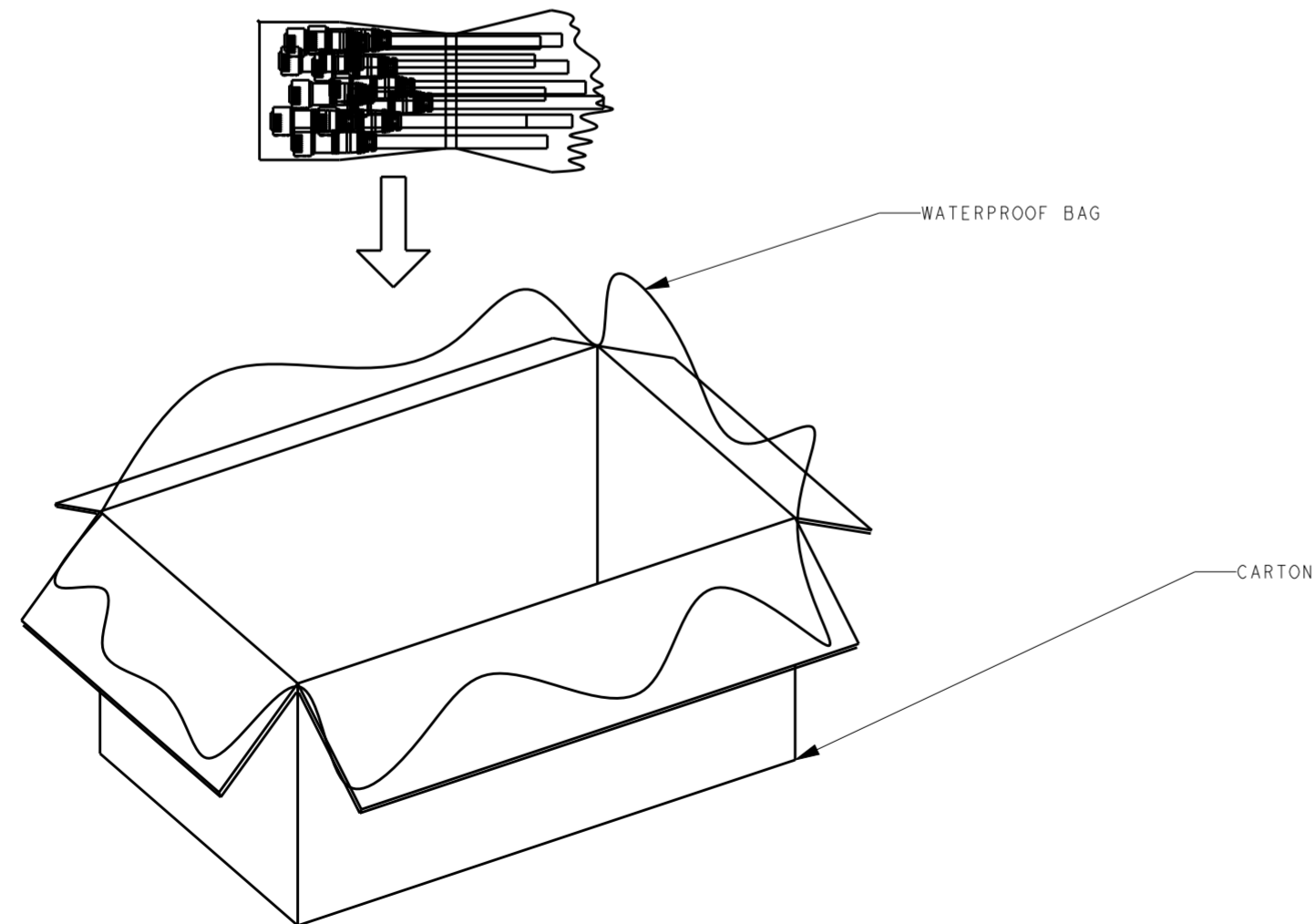

P/N	PARTS PER CARTON (PCS)
9-2834000-1	500
9-2834000-2	260
9-2834000-3	90
9-2834000-4	60

THIS DRAWING IS A CONTROLLED DOCUMENT.		DWN SHI MING 10SEP2014	STE TE Connectivity	
DIMENSIONS: mm		CHK SHI MING 10SEP2014		
TOLERANCES UNLESS OTHERWISE SPECIFIED:		APVD XU XIANG 10SEP2014	NAME 2P MALE CABLE ASSEMBLY CIRCULAR LIGHTING SEALED CONN.	
0 PLC ±-		PRODUCT SPEC 108-137041	SIZE A2	
1 PLC ±1.0		APPLICATION SPEC 114-137041	CAGE CODE -	DRAWING NO C-2834000
2 PLC ±0.5		WEIGHT -	RESTRICTED TO -	
3 PLC ±-		MATERIAL -	SCALE NTS	SHEET 2 OF 2
4 PLC ±-		Customer Drawing	REV BI	
ANGLES ±-				
FINISH ±-				