

# FTDI Chip

## VA800A-SPI

### USB 2.0 Hi-Speed to MPSSE SPI Module



## 1 Introduction

The **USB2.0 Hi-Speed to MPSSE SPI Module, VA800A-SPI**, is a small electronic circuit board, utilising the FTDI FT232H.

The 10 pin connector on the module fits directly to the FTDI VM800B and VM800C graphic display modules. This allows direct control of the EVE FT800 devices with an SPI interface from a USB host.

All USB signalling and protocols are handled on the module.

For full details of the FT232H IC, consult the FT232H datasheet, [DS\\_FT232H](#).

### 1.1 Features

- USB 2.0 Hi-Speed (480Mbps/Second) and Full Speed (12Mbps/Second) compatible
- Entire USB protocol handled on the chip – No USB-specific firmware programming required
- USB Type B micro connector
- USB bus powered
- Synchronous Serial (MPSSE) data rates of up to 30Mbps on SPI
- 1kByte receive and transmit buffers for high data throughput
- 3.3V Level IO
- Power indicator LED
- SPI SS# active indicator LED
- Adjustable receive buffer timeout
- Support for USB suspend and resume
- Low operating and USB suspend current
- Low USB bandwidth consumption
- UHCI / OHCI / EHCI host controller compatible
- -40°C to +85°C operating temperature range
- FTDI's FTDI Chip's royalty-free D2XX drivers eliminate the requirement for USB driver development in most cases

Neither the whole nor any part of the information contained in, or the product described in this manual, may be adapted or reproduced in any material or electronic form without the prior written consent of the copyright holder. This product and its documentation are supplied on an as-is basis and no warranty as to their suitability for any particular purpose is either made or implied. Future Technology Devices International Ltd will not accept any claim for damages howsoever arising as a result of use or failure of this product. Your statutory rights are not affected. This product or any variant of it is not intended for use in any medical appliance, device or system in which the failure of the product might reasonably be expected to result in personal injury. This document provides preliminary information that may be subject to change without notice. No freedom to use patents or other intellectual property rights is implied by the publication of this document. Future Technology Devices International Ltd, Unit 1, 2 Seaward Place, Centurion Business Park, Glasgow G41 1HH United Kingdom. Scotland Registered Company Number: SC136640

## 2 Description

The **USB2.0 Hi-Speed to MPSSE SPI Module** is a small electronic circuit board, utilising the FT232H. This device handles all the USB signalling and protocols. The module provides a fast, simple way to connect devices with 3.3 Volt digital interface to USB. For full details of the IC, consult the FT232H datasheet, [DS\\_FT232H](#).

The integrated FT232H device incorporates a command processor called the Multi-Protocol Synchronous Serial Engine (MPSSE). The purpose of the MPSSE command processor is to communicate with devices which use synchronous protocols (such as JTAG, SPI or I<sup>2</sup>C) in an efficient manner. Full details are available in the [MPSSE application note - AN\\_108](#).

The module is terminated by ten female pin headers which can be interfaced to a male header. Pin signals are compliant with CMOS logic at 3.3 volts.

The FT232H is a single channel USB 2.0 Hi-Speed (480Mb/s) to UART/FIFO IC. It can be configured in a variety of industry standard serial or parallel interfaces at up to 30Mbps, such as MPSSE - JTAG, SPI, I<sup>2</sup>C.

The VA800A-SPI MPSSE module is configured for SPI only. The 10 pin connector fits to the VM800B and VM800C graphic display modules directly.

The module is powered from a USB host port and is USB2.0 Hi-Speed compatible.

The VA800A-SPI MPSSE module requires USB device drivers, available free from <http://www.ftdichip.com>. The D2XX driver is used with application software to directly access the FT232H in the module through a DLL. This is illustrated in the Figure 2-1

The VA800A-SPI MPSSE module uses the FTDI's FT232H USB to serial IC device.

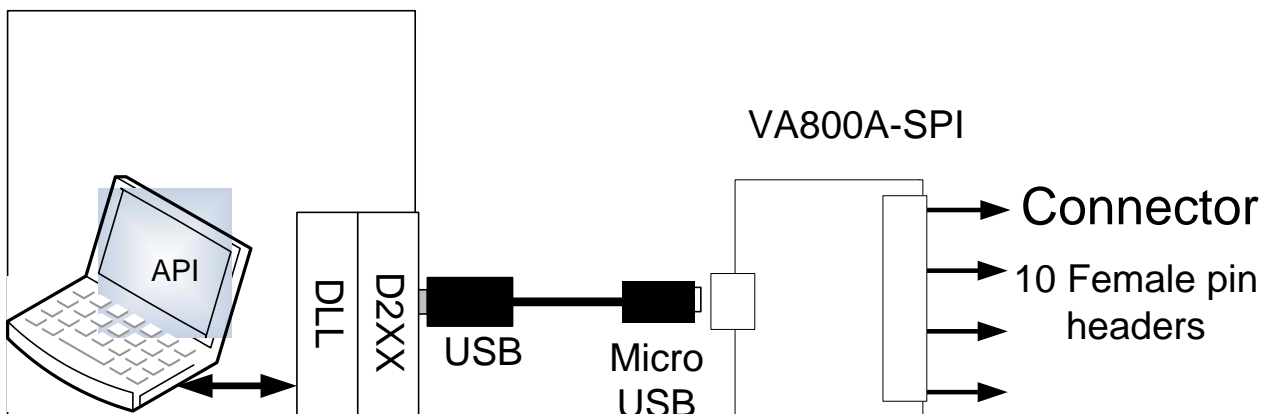

## Software application access to USB via D2XX

**Figure 2-1 Using the VA800A-SPI MPSSE module**

## 2.1 Ordering Information

The following Table 2-1 gives details of the available VA800A-SPI MPSSE modules.

Part Number	Description	End Connector	Cable details
VA800A-SPI	USB to SPI module	Single row, receptacle x 10	N.A.

**Table 2-1 VA800A-SPI MPSSE module Descriptions and Part Numbers**

**Note 1:** The VCC power output signal is 5.0V. The source of 5.0V is the USB VBUS input, which is switched onto the power output signal.

## 2.2 Certifications

The FTDI VA800A-SPI MPSSE modules are fully RoHS compliant. At the time of writing this datasheet the modules were being CE and FCC tested.

## **Table of Contents**

<b>1</b>	<b>Introduction.....</b>	<b>1</b>
<b>1.1</b>	<b>Features.....</b>	<b>1</b>
<b>2</b>	<b>Description.....</b>	<b>2</b>
<b>2.1</b>	<b>Ordering Information.....</b>	<b>0</b>
<b>2.2</b>	<b>Certifications .....</b>	<b>0</b>
<b>3</b>	<b>Typical Applications .....</b>	<b>2</b>
<b>3.1</b>	<b>Driver Support .....</b>	<b>2</b>
<b>4</b>	<b>VA800A-SPI MPSSE module connection &amp; Mechanical Details .....</b>	<b>3</b>
<b>4.1</b>	<b>VA800A-SPI MPSSE module Electrical Parameters.....</b>	<b>4</b>
4.1.1	VA800A-SPI MPSSE module I/O Characteristics.....	4
<b>5</b>	<b>Module PCB Circuit Schematic.....</b>	<b>6</b>
<b>6</b>	<b>Contact Information.....</b>	<b>7</b>
	<b>Appendix A - Module EEPROM Configuration.....</b>	<b>11</b>
	<b>Appendix B - List of Figures and Tables .....</b>	<b>12</b>
	List of Figures .....	12
	List of Tables.....	12
	<b>Appendix C – Revision History .....</b>	<b>13</b>

### 3 Typical Applications

- Controlling the EVE series of graphics controllers
- USB to SPI interfaces
- Rapid USB integration into existing electronic systems
- Prototyping platform for USB interface on new systems

#### 3.1 Driver Support

##### Royalty free D2XX *Direct Drivers*

##### (USB Drivers + DLL S/W Interface)

- Microsoft Windows 8 and 8 - 64-bit
- Microsoft Windows 7 and Windows 7 64-bit
- Microsoft Windows Vista and Vista 64-bit
- Microsoft Windows XP and XP 64-bit
- Microsoft Windows 2000, Server 2003, XP and Server 2008
- Microsoft Windows CE 4.2, 5.0 and 6.0
- Linux 2.6.32 or later

The drivers listed above are all available to download for free from <http://www.ftdichip.com/Drivers/D2XX.htm>

## 4 VA800A-SPI MPSSE module connection & Mechanical Details

Figure 4-1 VA800A-SPI MPSSE module layout Shows the VA800A-SPI MPSSE module layout. The module is 29mm x 32mm is dimension.

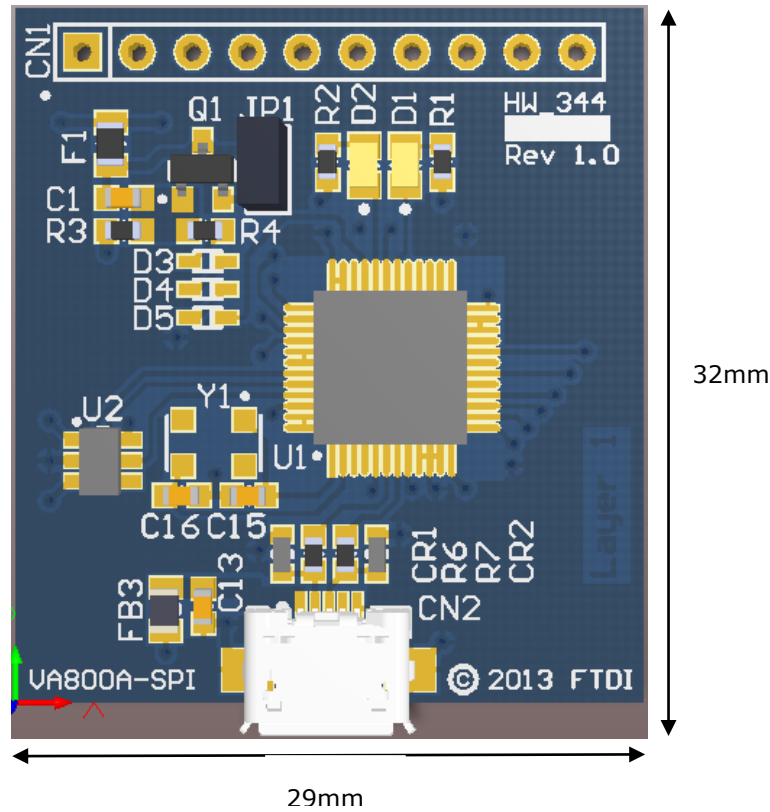

**Figure 4-1 VA800A-SPI MPSSE module layout**

The following Table 4-1 shows the module signals for these signals on the VA800A-SPI MPSSE module.

Pin No.	Name	Type	Description
CN1-1	SCLK	O	SPI Clock input
CN1-2	MOSI	O	Master Out Slave in
CN1-3	MISO	I	Master In Slave out
CN1-4	CS#	O	Chip select , active low
CN1-5	INT#	I	Interrupt
CN1-6	PD#	O	Active low, SPI device power down output.
CN1-7	5V	P	5V power supply
CN1-8	--	--	NC
CN1-9	GND	P	Ground
CN1-10	GND	P	Ground

**Table 4-1 VA800A-SPI MPSSE module Connections (numbers refer to pad numbers on the PCB)**

## 4.1 VA800A-SPI MPSSE module Electrical Parameters

Parameter	Description	Minimum	Typical	Maximum	Units	Conditions
VCC	Output Power Voltage	4.75	5	5.25	V	
I <sub>o</sub>	Output Power Current	-	-	400	mA	
T	Operating Temperature Range	-40		+85	°C	

**Table 4-2 VA800A-SPI MPSSE Operating Parameters**

### 4.1.1 VA800A-SPI MPSSE module I/O Characteristics

Parameter	Description	Minimum	Typical	Maximum	Units	Conditions
Voh	Output Voltage High	2.40	3.14		V	I <sub>oh</sub> = +/-2mA I/O Drive strength* = 4mA
			3.20		V	I/O Drive strength* = 8mA
			3.22		V	I/O Drive strength* = 12mA
			3.22		V	I/O Drive strength* = 16mA
Vol	Output Voltage Low		0.18	0.40	V	I <sub>ol</sub> = +/-2mA I/O Drive strength* = 4mA
			0.12		V	I/O Drive strength* = 8mA
			0.08		V	I/O Drive strength* = 12mA
			0.07		V	I/O Drive strength* = 16mA
Vil	Input low Switching Threshold		-	0.80	V	LVTTTL
Vih	Input High Switching Threshold	2.00	-		V	LVTTTL
Vt	Switching Threshold		1.50		V	LVTTTL
Vt-	Schmitt trigger negative going threshold voltage	0.80	1.10	-	V	
Vt+	Schmitt trigger positive going threshold voltage		1.60	2.00	V	
Rpu	Input pull-up resistance	40	75	190	KΩ	V <sub>in</sub> = 0
Rpd	Input pull-down resistance	40	75	190	KΩ	V <sub>in</sub> = VCCIO

Parameter	Description	Minimum	Typical	Maximum	Units	Conditions
Iin	Input Leakage Current	15	45	85	μA	Vin = 0
Ioz	Tri-state output leakage current		±10		μA	Vin = 5.5V or 0

**Table 4-3 VA800A-SPI MPSSE module I/O Pin Characteristics**

\* The I/O drive strength and slow slew-rate are configurable in the EEPROM.

The I/O pins are +3.3v cells, which are +5V tolerant





## 6 Contact Information

### Head Quarters – Singapore

Bridgetek Pte Ltd  
178 Paya Lebar Road, #07-03  
Singapore 409030  
Tel: +65 6547 4827  
Fax: +65 6841 6071

E-mail (Sales) [sales.apac@brtchip.com](mailto:sales.apac@brtchip.com)  
E-mail (Support) [support.apac@brtchip.com](mailto:support.apac@brtchip.com)

### Branch Office – Taipei, Taiwan

Bridgetek Pte Ltd, Taiwan Branch  
2 Floor, No. 516, Sec. 1, Nei Hu Road, Nei Hu District  
Taipei 114  
Taiwan, R.O.C.  
Tel: +886 (2) 8797 5691  
Fax: +886 (2) 8751 9737

E-mail (Sales) [sales.apac@brtchip.com](mailto:sales.apac@brtchip.com)  
E-mail (Support) [support.apac@brtchip.com](mailto:support.apac@brtchip.com)

### Branch Office - Glasgow, United Kingdom

Bridgetek Pte. Ltd.  
Unit 1, 2 Seaward Place, Centurion Business Park  
Glasgow G41 1HH  
United Kingdom  
Tel: +44 (0) 141 429 2777  
Fax: +44 (0) 141 429 2758

E-mail (Sales) [sales.emea@brtchip.com](mailto:sales.emea@brtchip.com)  
E-mail (Support) [support.emea@brtchip.com](mailto:support.emea@brtchip.com)

### Branch Office – Vietnam

Bridgetek VietNam Company Limited  
Lutaco Tower Building, 5th Floor, 173A Nguyen Van  
Tro, Ward 11, Phu Nhuan District,  
Ho Chi Minh City, Vietnam  
Tel : 08 38453222  
Fax : 08 38455222

E-mail (Sales) [sales.apac@brtchip.com](mailto:sales.apac@brtchip.com)  
E-mail (Support) [support.apac@brtchip.com](mailto:support.apac@brtchip.com)

### Web Site

<http://brtchip.com/>

### Distributor and Sales Representatives

Please visit the Sales Network page of the [Bridgetek Web site](#) for the contact details of our distributor(s) and sales representative(s) in your country.

System and equipment manufacturers and designers are responsible to ensure that their systems, and any Future Technology Devices International Ltd (FTDI) devices incorporated in their systems, meet all applicable safety, regulatory and system-level performance requirements. All application-related information in this document (including application descriptions, suggested FTDI devices and other materials) is provided for reference only. While FTDI has taken care to assure it is accurate, this information is subject to customer confirmation, and FTDI disclaims all liability for system designs and for any applications assistance provided by FTDI. Use of FTDI devices in life support and/or safety applications is entirely at the user's risk, and the user agrees to defend, indemnify and hold harmless FTDI from any and all damages, claims, suits or expense resulting from such use. This document is subject to change without notice. No freedom to use patents or other intellectual property rights is implied by the publication of this document. Neither the whole nor any part of the information contained in, or the product described in this document, may be adapted or reproduced in any material or electronic form without the prior written consent of the copyright holder. Future Technology Devices International Ltd, Unit 1, 2 Seaward Place, Centurion Business Park, Glasgow G41 1HH, United Kingdom. Scotland Registered Company Number: SC136640

## Appendix A - Module EEPROM Configuration

Each VA800A-SPI MPSSE module is controlled by the FTDI FT232H IC. This FT232H device contains an EEPROM which contains the USB configuration descriptors for that device. When the module is plugged into a PC or a USB reset is performed, the PC will read these descriptors. The default values stored into the internal EEPROM are defined in the following table –

Parameter	Value	Notes
USB Vendor ID (VID)	0403h	FTDI default VID (hex)
USB Product ID (PID)	6014h	FTDI default PID (hex)
Serial Number Enabled?	Yes	
Serial Number	See Note	A unique serial number is generated and programmed into the EEPROM during device final test.
Manufacturer Name	FTDI	
Product Description	See note	VA800A-SPI
Max Bus Power Current	500mA	Includes power available from the module plus power required for the FT232H
Power Source	Bus Powered	
Device Type	FT232H	
USB Version	0200	Returns USB 2.0 device description to the host. Note: The device is a USB 2.0 Hi-Speed device (480Mb/s).
Remote Wake Up	Disabled	500uA suspend limit when in this state
High Current I/Os	Enabled	Enables the high drive level on the CBUS I/O pins.
Invert TXD	Disabled	Signal on this pin becomes TXD# if enable.
Invert RXD	Disabled	Signal on this pin becomes RXD# if enable.
Invert RTS#	Disabled	Signal on this pin becomes RTS if enable.
Invert CTS#	Disabled	Signal on this pin becomes CTS if enable.

### Default Internal EEPROM Configuration

**Note:**

The internal EEPROM in the module can be re-programmed over USB using the utility program FT\_PROG. Both can be downloaded from [www.ftdichip.com](http://www.ftdichip.com).

## **Appendix B - List of Figures and Tables**

### **List of Figures**

Figure 2-1 Using the VA800A-SPI MPSSE module.....	2
Figure 4-1 VA800A-SPI MPSSE module layout .....	3
Figure 5-1 Circuit Schematic of VA800A-SPI.....	6

### **List of Tables**

Table 2-1 VA800A-SPI MPSSE module Descriptions and Part Numbers.....	0
Table 4-1 VA800A-SPI MPSSE module Connections (numbers refer to pad numbers on the PCB) .....	3
Table 4-2 VA800A-SPI MPSSE Operating Parameters .....	4
Table 4-3 VA800A-SPI MPSSE module I/O Pin Characteristics.....	5

## Appendix C – Revision History

Document Title: VA800A-SPI Datasheet  
Document Reference No.: BRT\_000005  
Clearance No.: BRT#009  
Product Page: <http://brtchip.com/product>  
Document Feedback: [DS\\_VA800A-SPI](#)

Revision	Changes	Date
Version 1.0	Initial Release	2013-10-24
Version 1.1	Dual branding to reflect the migration of the product to the Bridgetek name – logo changed, copyright changed, contact information changed	2016-09-13