



Features

- Integrated 2.4GHz to 2.4GHz b/g/n Amplifier, SP3T Switch, and Power Detector Coupler
- Single Supply Voltage 3.0V to 4.8V
- Output Power:
11b=23dBm Meeting Spectral Mask
11n=20dBm at <2.5% EVM
- Low Height Package, Suited for SiP and CoB Designs

Applications

- Cellular handsets
- Mobile devices
- Tablets
- Consumer electronics
- Gaming
- Netbooks/Notebooks
- TV/monitors/video
- SmartEnergy

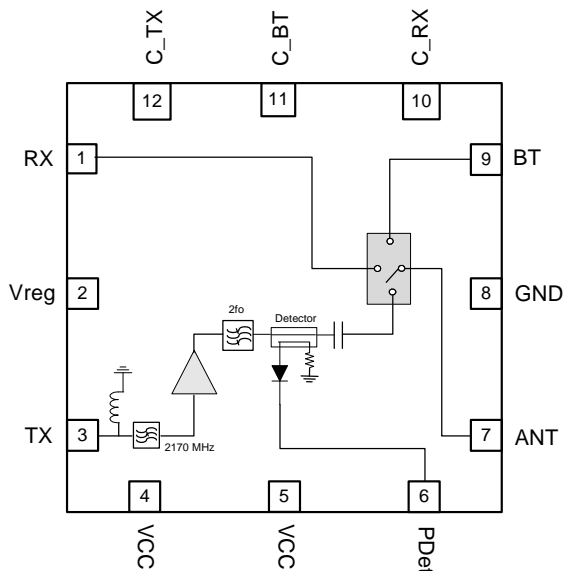

Functional Block Diagram

Product Description

The RF5385 provides an integrated front-end solution for WiFi 802.11b/g/n and Bluetooth® systems. The ultra small form factor package and integrated matching greatly reduces the number of external components and layout area in the customer application. This simplifies the total Front-end solution by reducing the bill of materials, system footprint, and assembly cost.

The RF5385 integrates a 2.4GHz Power Amplifier (PA), 2170MHz notch filter for coexistence with cellular radios, second harmonic attenuation, power detector coupler for improved accuracy, and a SP3T switch capable of simultaneous reception for WiFi and Bluetooth®. The device is provided in a 2.5mmx2.5mmx0.5mm, 12-pin package. This module meets or exceeds the RF Front-end needs of IEEE 802.11b/g/n WiFi RF systems.

Ordering Information

RF5385SQ	Standard 25-piece bag
RF5385SR	Standard 100-piece bag
RF5385TR7	Standard 2500-piece reel (13")
RF5385PCK-410	Fully Assembled Evaluation Board with 5-piece Sample

Optimum Technology Matching® Applied

- | | | | |
|---|--------------------------------------|--|-----------------------------------|
| <input type="checkbox"/> GaAs HBT | <input type="checkbox"/> SiGe BiCMOS | <input checked="" type="checkbox"/> GaAs pHEMT | <input type="checkbox"/> GaN HEMT |
| <input type="checkbox"/> GaAs MESFET | <input type="checkbox"/> Si BiCMOS | <input type="checkbox"/> Si CMOS | <input type="checkbox"/> RF MEMS |
| <input checked="" type="checkbox"/> InGaP HBT | <input type="checkbox"/> SiGe HBT | <input type="checkbox"/> Si BJT | <input type="checkbox"/> LDMS |

RF MICRO DEVICES®, RFMD®, Optimum Technology Matching®, Enabling Wireless Connectivity™, PowerStar®, POLARIS™ TOTAL RADIO™ and UltimateBlue™ are trademarks of RFMD, LLC. BLUETOOTH is a trademark owned by Bluetooth SIG, Inc., U.S.A. and licensed for use by RFMD. All other trade names, trademarks and registered trademarks are the property of their respective owners. ©2006, RF Micro Devices, Inc.

Absolute Maximum Ratings

Parameter	Rating	Unit
Supply Voltage	-0.5 to +5.5	V _{DC}
Power Control Voltage (P _A ENABLE)	-0.5 to 3.6	V _{DC}
DC Supply Current	700	mA
Input RF Power	+5	dBm
Operating Ambient Temperature	-40 to +85	°C
Storage Temperature	-40 to +150	°C
Moisture Sensitivity	MSL2	



Caution! ESD sensitive device.

Exceeding any one or a combination of the Absolute Maximum Rating conditions may cause permanent damage to the device. Extended application of Absolute Maximum Rating conditions to the device may reduce device reliability. Specified typical performance or functional operation of the device under Absolute Maximum Rating conditions is not implied.

The information in this publication is believed to be accurate and reliable. However, no responsibility is assumed by RF Micro Devices, Inc. ("RFMD") for its use, nor for any infringement of patents, or other rights of third parties, resulting from its use. No license is granted by implication or otherwise under any patent or patent rights of RFMD. RFMD reserves the right to change component circuitry, recommended application circuitry and specifications at any time without prior notice.



RFMD Green: RoHS compliant per EU Directive 2002/95/EC, halogen free per IEC 61249-2-21, < 1000ppm each of antimony trioxide in polymeric materials and red phosphorus as a flame retardant, and <2% antimony in solder.

Parameter	Specification			Unit	Condition	
	Min.	Typ.	Max.			
Compliance					IEEE802.11b/g/n Standards; FCC CFG 15.247, .205, .209; EN and JDEC.	
Transmit						
Nominal Operating Conditions					V _{CC} =3.3V to 4.2V, V _{REG} =2.85V to 2.95V, Switch Control voltage=2.7V to 3.6V, Temp= -10°C to +70°C, Freq=2.412GHz to 2.484GHz, Unless otherwise noted.	
Frequency Range	2.4		2.5	GHz	Test frequency range: 2412MHz to 2484 MHz	
Power Supply	3.0	3.3	4.8	V		
	2.7			V	Derated performance	
V _{REG} Voltage						
	ON	2.85	2.9	2.95	V	
	OFF	0		0.2	V	
Output Power						
	11n	18.5	19		dBm	V _{CC} ≥3.0V OFDM 54Mbps
	11n	19.5	20		dBm	V _{CC} ≥3.3V OFDM 54Mbps
	11g	20	20.5		dBm	V _{CC} ≥3.3V OFDM 54Mbps
	11b	22	23		dBm	11Mbps, CCK, V _{CC} ≥3.0V
EVM						
	11n		2.5	3	%	P _{OUT} =20dBm; V _{CC} ≥3.3V; 54Mbps OFDM; Room Temp
			2.5	3	%	P _{OUT} =19.5dBm; V _{CC} ≥3.3V; 54Mbps OFDM; Over Temp Range
			2.5	3	%	P _{OUT} =19dBm; V _{CC} ≥3.0V; 54Mbps OFDM; Room Temp
			2.5	3	%	P _{OUT} =18.5dBm; V _{CC} ≥3.0V; 54Mbps OFDM; Over Temp Range
	11g		3.5	4	%	P _{OUT} =20.5dBm; V _{CC} ≥3.3V; 54Mbps OFDM; Room Temp
			3.5	4	%	P _{OUT} =20dBm; V _{CC} ≥3.3V; 54Mbps OFDM; Over Temp Range
Adjacent Channel Power						11b; CCK 11Mbps; at rated power (note 3)
	ACP1		-36	-33	dBc	f _c +/- 11MHz; V _{CC} ≥ 3.0V
	ACP2		-56	-52	dBc	f _c +/- 22MHz; V _{CC} ≥ 3.0V

Parameter	Specification			Unit	Condition
	Min.	Typ.	Max.		
Transmit (continued)					
Gain	24	25	27	dB	At rated P _{OUT}
	22	25	29	dB	Over Temp Range, Frequency, and Voltage
Gain Variance Slope					
Channel 20MHz BW	-0.5		+0.5	dB	
Frequency 100MHz BW	-2		+2	dB	In-Band variance 2.4GHz to 2.5GHz
Out of Band Gain					
2170MHz	6	8		dBc	CW signal, nominal conditions
Power Detector					
Output Power Range	0		25	dBm	
Voltage Range	0.1		1.5	V _{DC}	
Filter Bandwidth		0.5		MHz	
Sensitivity					
P _{OUT} < 10dBm	10			mV/dB	
P _{OUT} > 10dBm	20			mV/dB	
Voltage Target at 20dBm P _{OUT}	0.65	0.7	0.75	V	11g, over supply voltage, room temp
Voltage Target at 23dBm P _{OUT}		0.85	1	V	11b, over supply voltage, room temp
Load Variation			±200	mV	up to 3:1 VSWR
Current Consumption					
Quiescent		170		mA	Nominal
	125		250	mA	All Conditions
Operating		250	295	mA	11g/n 64QAM, P _{OUT} =20dBm; nominal conditions
		250	325	mA	11g/n 64QAM, P _{OUT} =19.5dBm; all conditions
		300	410	mA	11b CCK 11Mbps, P _{OUT} =23dBm; all conditions
FEM Leakage Current			500	nA	V _{CC} =ON, V _{REG} OFF ≤0.2V, room temp
V _{REG} Current		3	5	mA	V _{REG} ON ≥2.85V, P _{OUT} =20dBm; all conditions
V _{REG} Leakage Current			50	nA	V _{REG} OFF ≤0.2V, room temp
Noise Figure		8	9	dB	
Input Return Loss	8	10		dB	
Thermal Resistance		47		°C/W	V _{CC} =4.8V, V _{REG} =2.95V, C _{TX} =3.3V, C _{RX} =C _{BT} =GND, P _{OUT} =20dBm, Modulation=OFDM 11g, Freq=2.45GHz, DC=100%, T=85 °C
Harmonics					P _{OUT} = 23dBm, 1Mbps, CCK BW=1MHz, uo to 3:1 load
Second			-20	dBm	4.80GHz to 5.00GHz, V _{CC} =3.3V, Temp=25 °C
Third			-20	dBm	7.20GHz to 7.50GHz, V _{CC} =3.3V, Temp=25 °C
Stability					
Output VSWR	4:1				No spurs above -43dBm from 0dBm to 23dBm, all phase angles, no spurious or oscillations.
Ruggedness					
Output VSWR	10:1				
Input Power	0			dBm	CW Input Power
Input Port Impedance		50		Ω	
Turn-On/Off Time			1	usec	Output stable to within 90% of final gain

Parameter	Specification			Unit	Condition
	Min.	Typ.	Max.		
2.4GHz Receive					
Frequency	2.4		2.5	GHz	Test frequency range: 2412 MHz to 2484 MHz
Insertion Loss		0.8	1.2	dB	Over supply voltage, temp range and frequency
Input P1dB	22			dBm	
Passband Ripple					
WiFi RX Mode	-0.2		+0.2	dB	
WiFi RX/BT Mode	-0.2		+0.2	dB	
WiFi RX Port Return Loss	10	12		dB	
WiFi RX Port Impedance		50		Ω	
Bluetooth®					
Frequency	2.4		2.5	GHz	Test frequency range: 2412 MHz to 2484 MHz
Insertion Loss					
BT TX/RX Loss		0.8	1.2	dB	Over supply voltage, temp range and frequency
Bluetooth Port Return Loss	10			dB	
Bluetooth Port Impedance		50		Ω	
Input P1dB	22			dBm	
Other Requirements					
Antenna Port Impedance		50		Ω	
Return Loss	10	12		dB	In WiFi RX or BT Mode
Isolation					
ANT to RX	20			dB	At rated P _{OUT} in TX Mode
Switch Control Voltage					
Low	0		0.2	V	
High	2.7		3.6	V	
Switch Control Current					
Low			0.5	μ A	
High			100	μ A	
ESD					
Human Body Model	1000			V	Pin-GND
Charge Device Model	1000			V	JESD22-C101
Case Temperature	-10		+70	$^{\circ}$ C	Full Performance
Extreme Case Temperature	-40		+85	$^{\circ}$ C	Reduced Performance

Note 1: The PA must operate with gated bias voltage input at 1% to 99% duty cycle.

Note 2: No external matching components.

Note 3: The output power for channels 1 and 11 may be reduced to meet FCC restricted band requirements.

Switch Control Logic Truth Table

Mode	C_TX	C_RX	C_BT	V _{REG}
TX Mode	High	Low	Low	High
RX Mode	Low	High	Low	Low
BT Mode	Low	Low	High	Low
Simultaneous	Low	High	High	Low

Pin	Function	Description
1	RX OUT	Receive port for 802.11b/g/n band. Internally matched to 50Ω. DC block required.
2	VREG	Regulated voltage for the PA bias control circuit. An external bypass capacitor may be needed on the VREG line for decoupling purposes.
3	TX IN	RF input for the 802.11b/g/n PA. Input is matched to 50Ω. DC block required.
4	VCC	PA voltage supply. See applications schematic for biasing and bypassing components.
5	VCC	Same as pin-4.
6	POWER DETECT	Power detector voltage for TX section. P _{DET} voltage varies with output power. May need external decoupling.
7	ANT	Port matched to 50Ω. DC block required.
8	GND	Ground connection.
9	BT PORT	<i>Bluetooth</i> ® RF Port. DC block required.
10	C_RX	Control pin for WiFi Receive Port. Please see truth table for proper settings.
11	C_BT	Control pin for <i>Bluetooth</i> ® Port. Please see truth table for proper settings.
12	C_TX	Control pin for WiFi Transmit Port. Please see truth table for proper settings.
Pkg Base	GND	Ground connection. The backside of the package should be connected to the ground plane through a short path, i.e., PCB vias under the device are recommended.

Pin Out

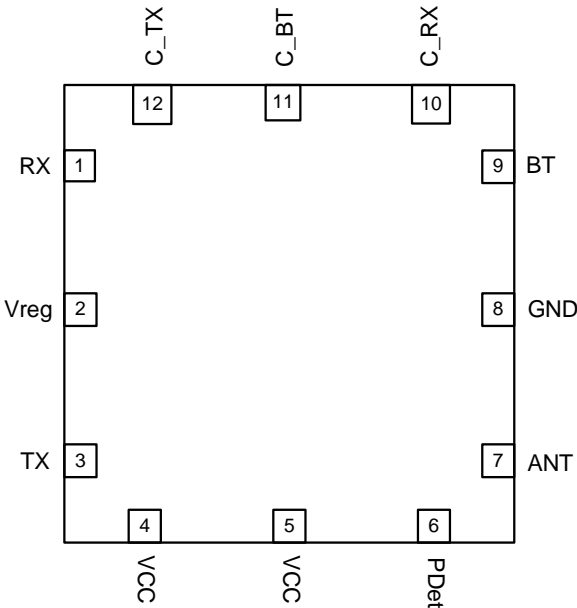

Application Schematic

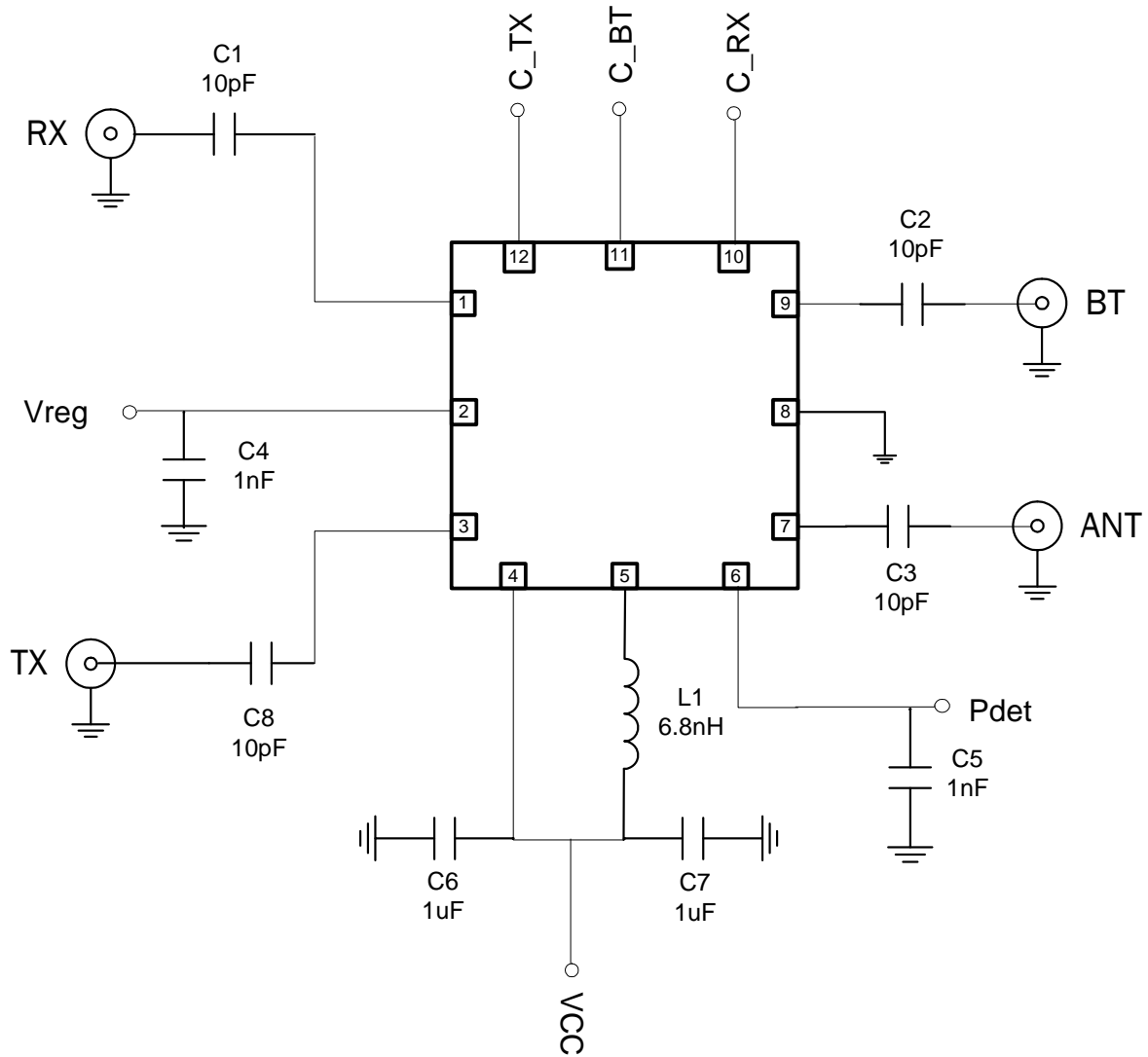

Note: Components C5 and C6 may not be needed in the final schematic. This will be dependent on board layout and noise coupling to these pins.

Package Outline Drawing

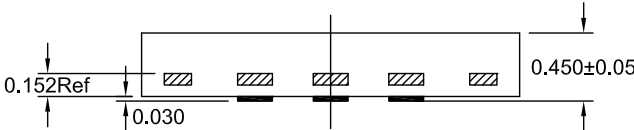
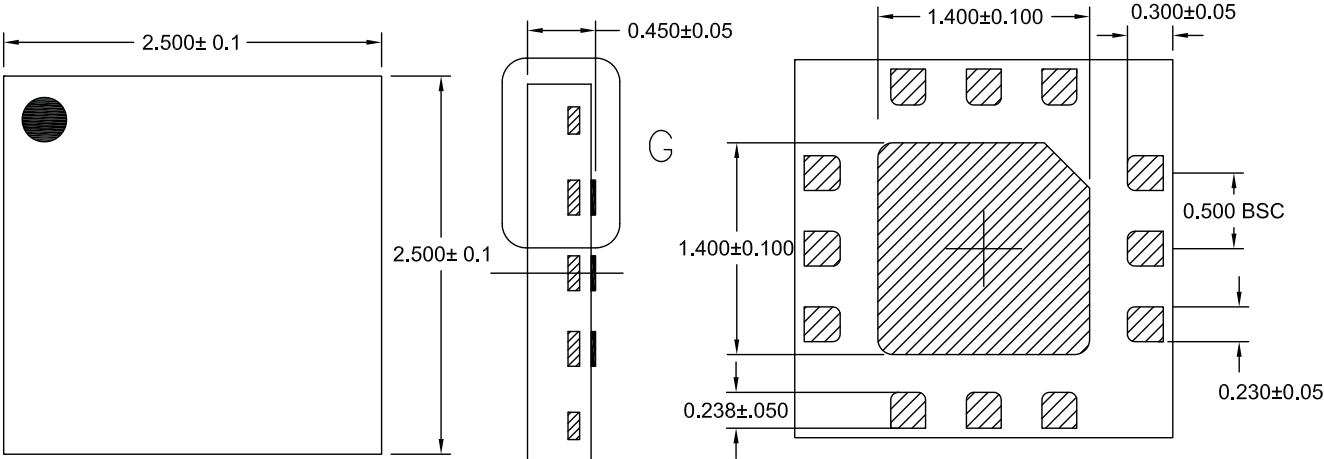

- 1) PIN 1 INDICATOR SHADED AREA
- 2) CHAMFERED AREA IS PIN 1 INDICATOR

PCB Recommendations

A = 0.250 x 0.250 mm Typ
 B = 1.400 x 1.400 mm 10% Rounded Rectangle

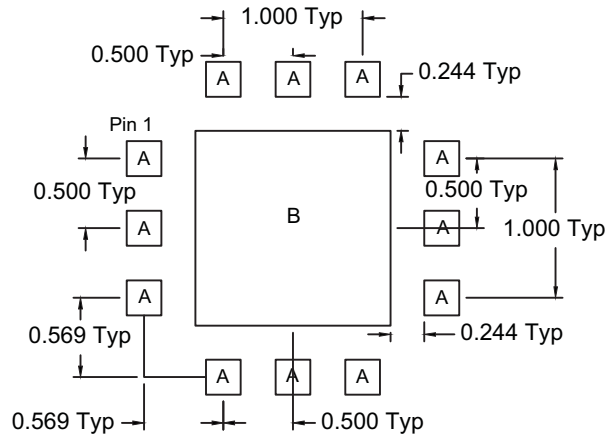

PCB METAL LAND PATTERN

A = 0.390 x 0.390 mm Typ
 B = 1.540 x 1.540 mm 10% Rounded Rectangle

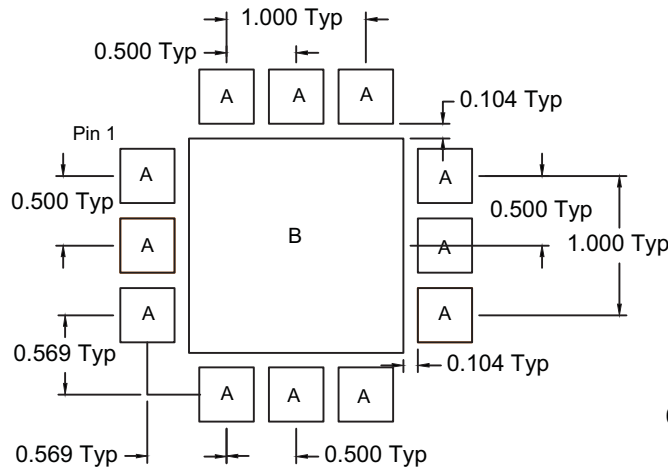

PCB SOLDER MASK LAND PATTERN

A = 0.225 x 0.225 mm Typ
 B = 1.260 x 1.260 mm 10% Rounded Rectangle

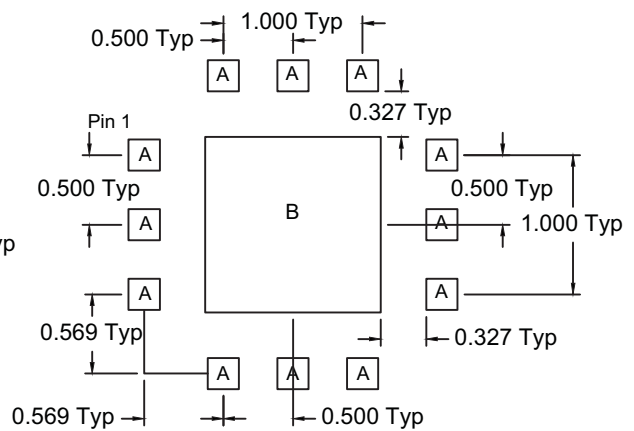

PCB STENCIL PATTERN

Thermal vias for center slug "B" should be incorporated into the PCB design. The number and size of thermal vias will depend on the application, the power dissipation, and the electrical requirements. Example of the number and size of vias can be found on the RFMD evaluation board layout.

RF5385 Performance Plots

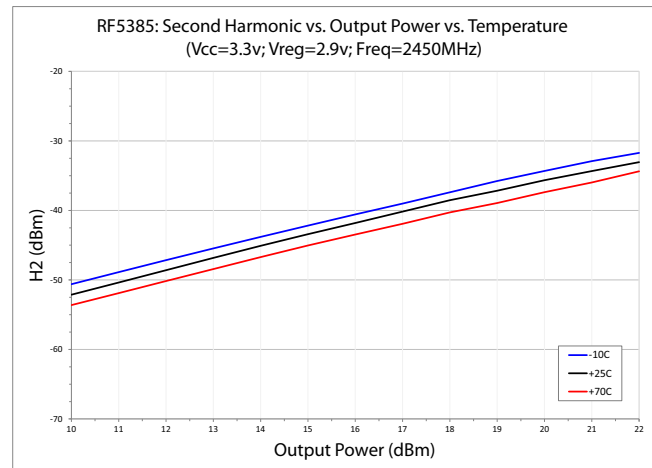
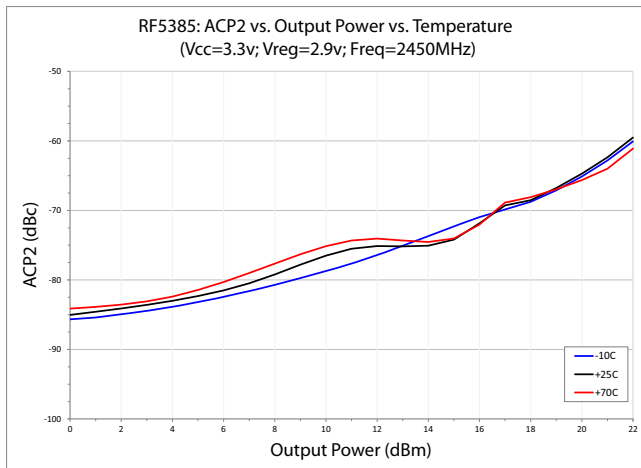
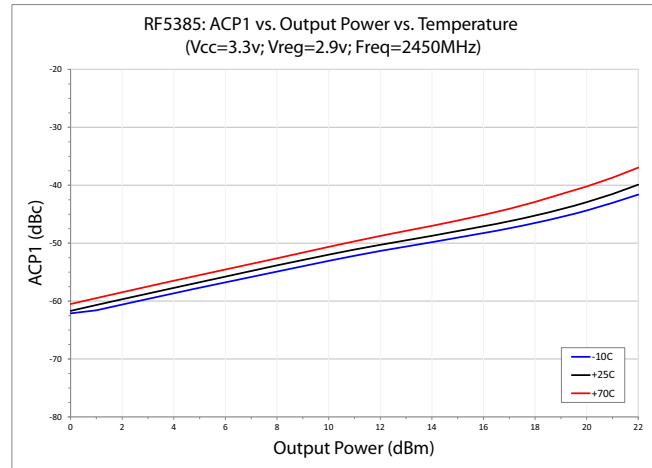
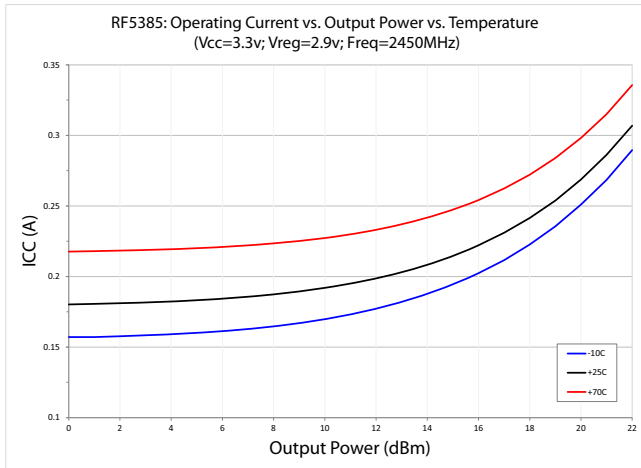
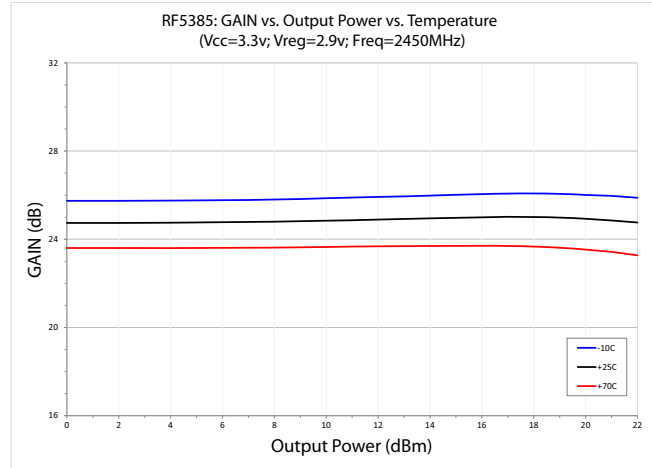
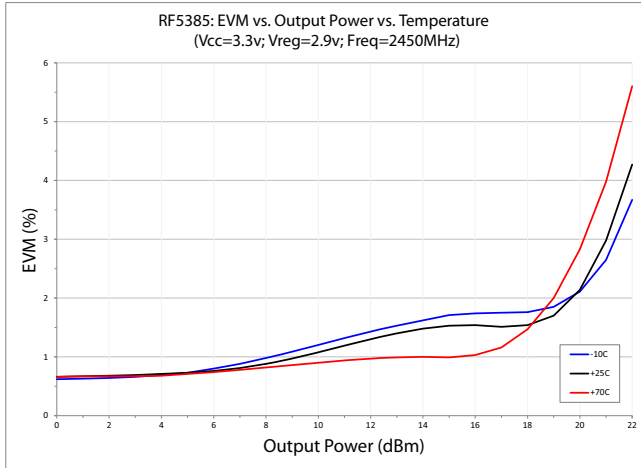

RF5385 Performance Plots

