

General Description

The RFFM4252 provides a complete integrated solution in a single front end module (FEM) for Wi-Fi 802.11b/g/n/ac and Bluetooth® systems. The small form factor and integrated matching minimizes layout area in the application and greatly reduces the number of external components.

The module allows true 5V supply without any modifications to the supply lines and performance is a balance of maximizing on highest linear output power and leading edge throughput while integrating die level filtering for 2nd and 3rd harmonics as well as LO spur rejection are included

The RFFM4252 integrates a 2 GHz power amplifier (PA), single pole three throw switch (SP3T) and bypassable low noise amplifier (LNA) into a single device.

Functional Block Diagram

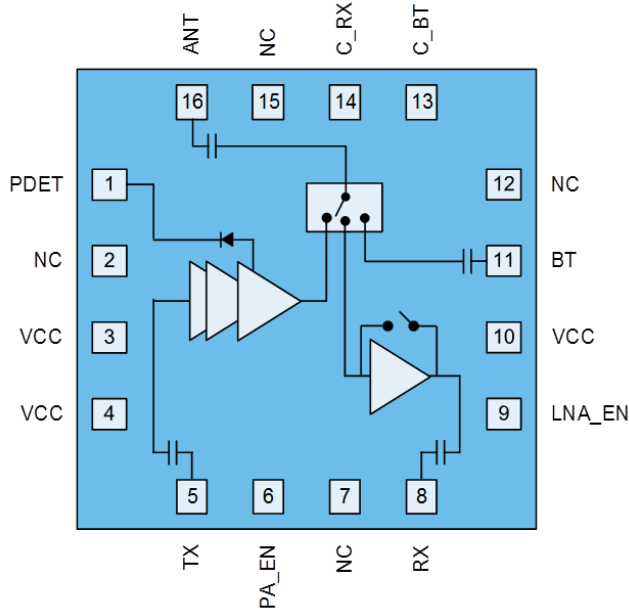

Top View

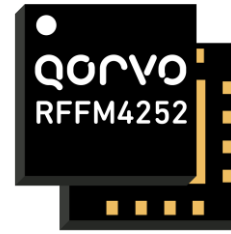

16 Pad 3 x 3 mm Laminate Package

Product Features

- 2412 – 2484 MHz
- P_{OUT} = +21dBm MCS8 HT40 -35dB Dynamic EVM
- P_{OUT} = +22dBm MCS7 HT20/40 -30.5dB Dynamic EVM
- P_{OUT} = +25dBm 802.11b DSSS 1Mbps Spectral Mask Compliance
- MCS11 Capable
- Optimized for +5 V Operation
- 29 dB Tx Gain
- 2.5 dB Noise Figure
- 15 dB Rx Gain & 7 dB Bypass Loss
- 8 dB 5 GHz Rejection on Rx Path

Applications

- Access Points
- Wireless Routers
- Residential Gateways
- Customer Premise Equipment
- Internet of Things

Ordering Information

Part No.	Description
RFFM4252SB	Sample bag with 5 pieces
RFFM4252SQ	Sample bag with 25 pieces
RFFM4252SR	7" reel with 100 pieces
RFFM4252TR7	7" reel with 2,500 pieces
RFFM4252PCK-410	Assembled Evaluation Board + 5 pcs

Absolute Maximum Ratings

Parameter	Rating
DC Supply Voltage	+6 V
DC Supply Current	600 mA
Tjunction (MTTF>0.7x10 ⁶ hours)	160 °C
Storage Temperature	-40 to +150 °C
TX RF Input Power into 50 Ω Load for 802.11b/g/n/ac (No Damage)	+10 dBm
RX LNA On RF Input Power (No Damage)	+10 dBm

Exceeding any one or a combination of the Absolute Maximum Rating conditions may cause permanent damage to the device. Extended application of Absolute Maximum Rating conditions to the device may reduce device reliability.

Recommended Operating Conditions

Parameter	Min	Typ	Max	Units
Operating Frequency	2412		2484	MHz
Device Voltage (V _{CC})	4.75	+5	5.25	V
PA Enable Voltage – High	+2.8	+3.1	V _{CC}	V
PA Enable Voltage – Low	+0		+0.2	V
T _{OPERATING} *	-10		+85	°C
Extended T _{OPERATING}	-40		+85	°C

* T_{OPERATING} is temperature at package ground

Electrical specifications are measured at specified test conditions. Specifications are not guaranteed over all recommended operating conditions.

Electrical Specifications

Parameter	Conditions	Min	Typ	Max	Units
TRANSMIT (TX-ANT) MODE					
Unless otherwise noted: V _{CC} =5V, T=+25°C, PA_EN=High, LNA_EN=Low, C_RX=Low, C_BT=Low					
11ac HT40 Output Power	MCS11 1024QAM		15		dBm
Dynamic EVM				-40	dB
11ac HT40 Output Power	MCS8 256QAM	20	21		dBm
			-36	-35	
11n HT20/40 Output Power	MCS7 64QAM	21	22		dBm
Dynamic EVM			-32	-30.5	
Margin to HT20/40 Spectral Mask	P _{OUT} = +23.5 dBm, 11ac MCS8			0	dBc
Margin to 802.11b Spectral Mask	P _{OUT} = +25 dBm, DSSS 1MBps			0	dBc
Gain		27	29		dB
Gain Variation	T = -10 to +85 °C	-3		+2	dB
Out of Band Gain	f = 1206-1242MHz		-3	0	dB
	f = 3618-3726MHz		-7	-3	dB
TX Port Return Loss		7	9		dB
ANT Port Return Loss		10	15		dB
Quiescent Current	RF Off		180		mA
Operating Current	P _{OUT} = +21 dBm		230	275	mA
	P _{OUT} = +25 dBm		300	380	mA
2 nd Harmonics	P _{OUT} = +25 dBm 802.11b DSSS 1MBps		-30	-25	dBm/MHz
3 rd Harmonics	P _{OUT} = +25 dBm 802.11b DSSS 1MBps		-35	-30	dBm/MHz
ANT-RX Isolation			37		dB
DC Power Detect Voltage	RF Off		0.12		V
	P _{OUT} = +20 dBm		0.66		V
	P _{OUT} = +25 dBm		1.10		V



RFFM4252

Wi-Fi Front End Module

RECEIVE (ANT-RX) LNA ON MODE	Unless otherwise noted: V _{CC} =5V, T=+25°C, PA_EN=Low, LNA_EN=High, C_RX=High, C_BT=Low				
Gain		13	15		dB
Gain Flatness	From 2412 to 2484 MHz	-1		+1	dB
Out of Band Gain	f = 5000-6000 MHz		-8	-2	dB
Noise Figure			2.5	3	dB
RX Port Return Loss			11		dB
ANT Port Return Loss			5		dB
Input P _{1dB}			-5		dBm
Rx Operating Current			13		mA
RECEIVE (ANT-RX) BYPASS MODE	Unless otherwise noted: V _{CC} =5V, T=+25°C, PA_EN=Low, LNA_EN=Low, C_RX=High, C_BT=Low				
Bypass Loss			7		dB
RX Port Return Loss			11		dB
ANT Port Return Loss			8		dB
Input P _{1dB}		+10	+15		dBm
Bypass Current			180		μA
BLUETOOTH (ANT-BT) MODE	Unless otherwise noted: V _{CC} =5V, T=+25°C, PA_EN=Low, LNA_EN=Low, C_RX=Low, C_BT=High				
Insertion Loss			1.4		dB
RX Port Return Loss			11		dB
ANT Port Return Loss			11		dB
Input P _{1dB}		+25	+30		dBm
ANT-RX Isolation			25		dB
GENERAL SPECIFICATIONS	Unless otherwise noted: V _{CC} =5V, T=+25°C				
FEM Leakage Current			35		μA
PA_EN Control Current			60		μA
LNA_EN Control Current			60		μA
C_RX Control Current	LNA On Mode		90		μA
	Bypass and Bluetooth Mode		3		μA
Ramp ON/OFF Time	10<->90% Ref from Control Voltage to RF Power		250		nS
Stability - Output VSWR	CW No Spurious above -41.25 dBm/MHz		4:1		
Output Power Range		0		25	dBm
Thermal Resistance, θ _{jc}	Junction to case, MCS0 P _{OUT}		44		°C/W

Notes:

Operating Mode	PA_EN	LNA_EN	C_RX	C_BT
Standby Mode	Low	Low	Low	Low
Transmit Mode	High	Low	Low	Low
LNA Mode	Low	High	High	Low
Bypass Mode	Low	Low	High	Low
Bluetooth Mode	Low	Low	Low	High

Evaluation Board Schematic

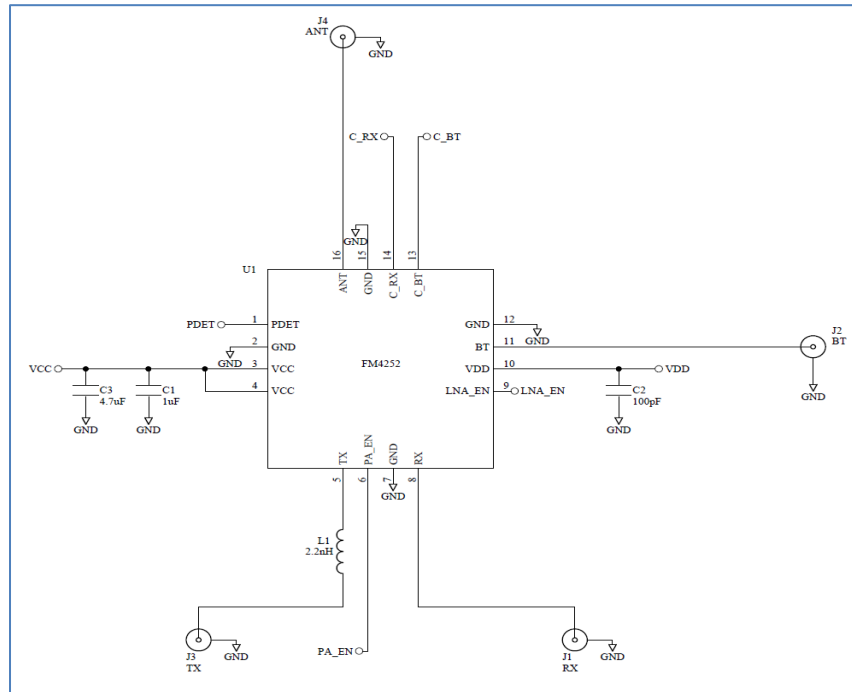

Timing Diagram

RF/DC Power On/Off Sequence

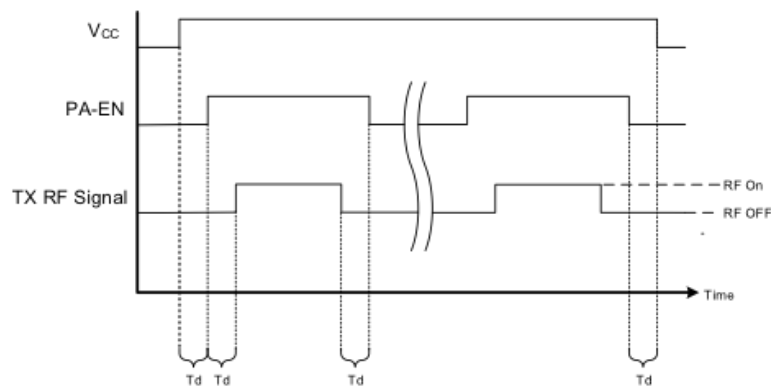

Note: Observe the timing sequence shown in the diagram above and described below.
DC and RF signal levels per data sheet specification

- Apply V_{CC} prior to turning on or pulsing PA enable.
- Turn off PA enable prior to turning off V_{CC} .
- Turn on PA enable prior to applying RF signal.
- Turn off RF signal prior to turning off PA enable.

Pin Configuration and Description

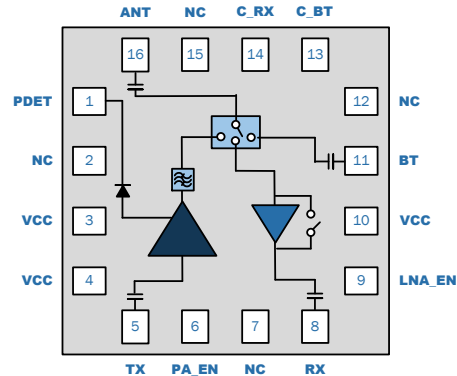

Top View

Pad No.	Label	Description
1	PDET	DC power detector. Provides an output voltage proportional to the RF output power level.
2	NC	No electrical connection. Recommend to connect to ground but it may be left floating.
3	VCC	2 nd stage supply voltage.
4	VCC	1 st stage supply voltage.
5	TX	RF input. Internally matched to 50 Ω and DC blocked.
6	PA_EN	Input enable bias voltage (Regulated internally)
7	NC	No electrical connection. Recommend to connect to ground but it may be left floating.
8	RX	RF output from the low noise amplifier. Internally matched to 50 Ω and DC blocked.
9	LNA_EN	LNA control voltage.
10	VDD	Supply voltage for LNA and regulator
11	BT	RF bi-directional port. Internally matched to 50 Ω and DC blocked.
12	GND	Ground connection.
13	C_BT	Transmit-receive control voltage.
14	C_RX	Switch control voltage.
15	GND	Ground connection.
16	ANT	RF bi-directional antenna port. Internally matched to 50 Ω and DC blocked.
Backside Paddle	GND	RF/DC ground. Use recommended via pattern to minimize inductance and thermal resistance. See PCB Mounting Pattern for suggested footprint.

Package Dimensions

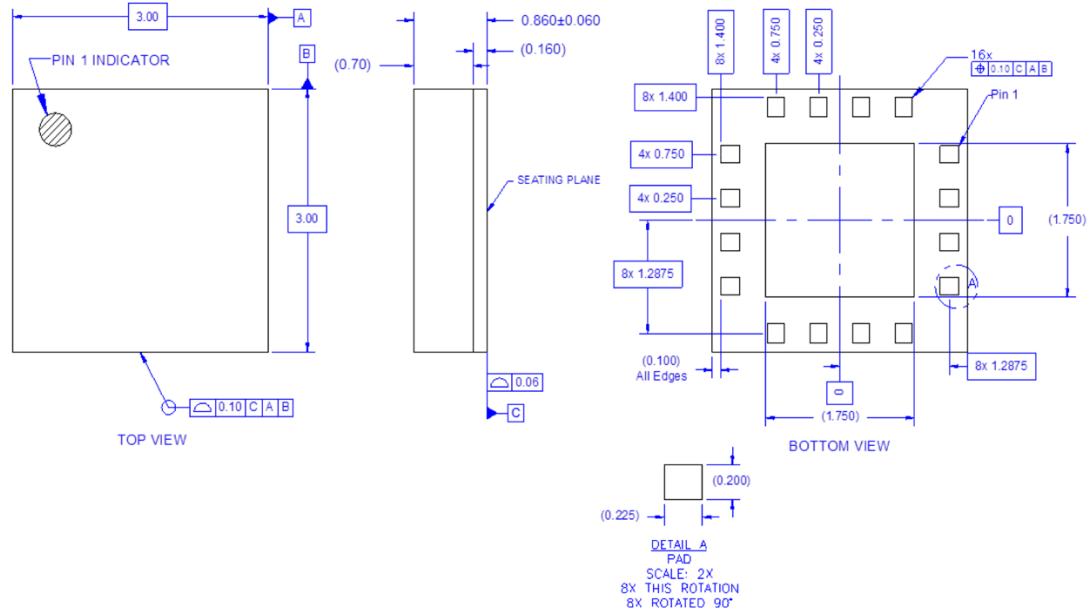

PCB Mounting Pattern

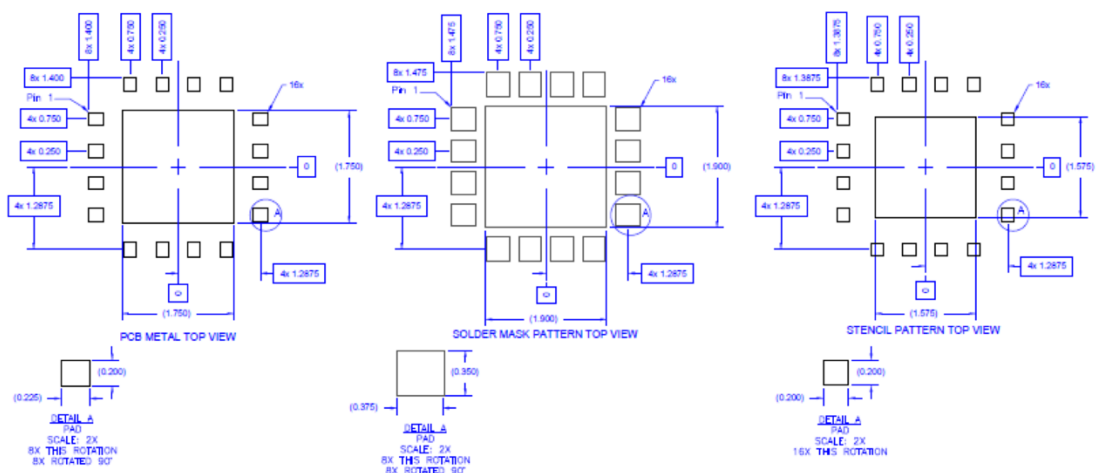

Notes:

1. All dimensions are in millimeters. Angles are in degrees.

Handling Precautions

Parameter	Rating	Standard
ESD – Human Body Model (HBM)	Class 1C	ANSI/ESDA/JEDEC JS-001
ESD – Charged Device Model (CDM)	Class C3	ANSI/ESDA/JEDEC JS-002
MSL – Moisture Sensitivity Level	Level 3	IPC/JEDEC J-STD-020



Caution!
ESD-Sensitive Device

Solderability

Compatible with both lead-free (260°C max. reflow temp.) and tin/lead (245°C max. reflow temp.) soldering processes.

Solder profiles available upon request.

Contact plating: NiPdAu

RoHS Compliance

This part is compliant with 2011/65/EU RoHS directive (Restrictions on the Use of Certain Hazardous Substances in Electrical and Electronic Equipment) as amended by Directive 2015/863/EU.

This product also has the following attributes:

- Lead Free
- Halogen Free (Chlorine, Bromine)
- Antimony Free
- TBBP-A (C₁₅H₁₂Br₄O₂) Free
- PFOS Free
- SVHC Free

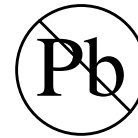

Contact Information

For the latest specifications, additional product information, worldwide sales and distribution locations:

Tel: 1-844-890-8163

Web: www.qorvo.com

Email: customer.support@qorvo.com

Important Notice

The information contained herein is believed to be reliable; however, Qorvo makes no warranties regarding the information contained herein and assumes no responsibility or liability whatsoever for the use of the information contained herein. All information contained herein is subject to change without notice. Customers should obtain and verify the latest relevant information before placing orders for Qorvo products. The information contained herein or any use of such information does not grant, explicitly or implicitly, to any party any patent rights, licenses, or any other intellectual property rights, whether with regard to such information itself or anything described by such information. **THIS INFORMATION DOES NOT CONSTITUTE A WARRANTY WITH RESPECT TO THE PRODUCTS DESCRIBED HEREIN, AND QORVO HEREBY DISCLAIMS ANY AND ALL WARRANTIES WITH RESPECT TO SUCH PRODUCTS WHETHER EXPRESS OR IMPLIED BY LAW, COURSE OF DEALING, COURSE OF PERFORMANCE, USAGE OF TRADE OR OTHERWISE, INCLUDING THE IMPLIED WARRANTIES OF MERCHANTABILITY AND FITNESS FOR A PARTICULAR PURPOSE.**

Without limiting the generality of the foregoing, Qorvo products are not warranted or authorized for use as critical components in medical, life-saving, or life-sustaining applications, or other applications where a failure would reasonably be expected to cause severe personal injury or death.

Copyright 2016 © Qorvo, Inc. | Qorvo is a registered trademark of Qorvo, Inc.