

THIS DRAWING IS UNPUBLISHED.

RELEASED FOR PUBLICATION AUGUST ,2006.

REVISIONS

© COPYRIGHT 2006 By -

ALL RIGHTS RESERVED.

P	LTR	DESCRIPTION	DATE	DWN	APVD
	A	RELEASE	05JUN2018	RZ	RS

NOTES:

- ① PACK IN ACCORDANCE WITH TE SPEC 107-3275
- ② Au PLATING: 50u"
- ③ Passivation
- ④ ALL DIMENSIONS ARE NOMINAL FOR REFERENCE ONLY UNLESS OTHERWISE STATED

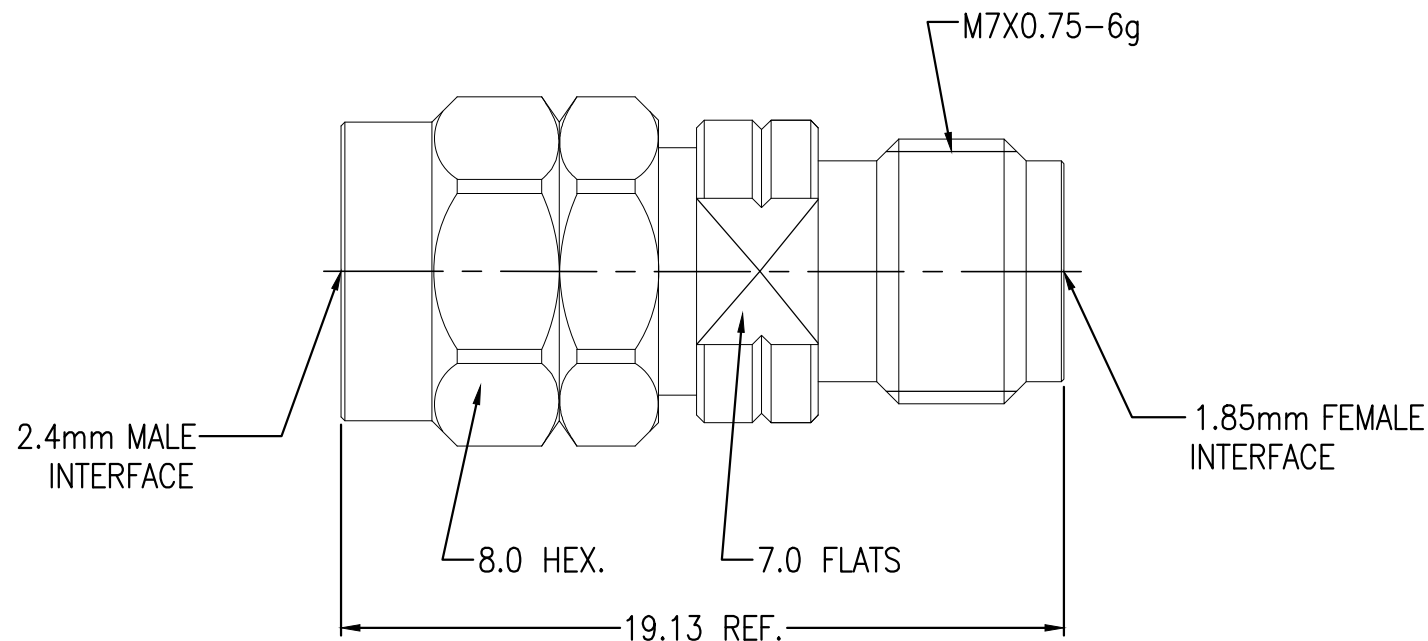

ELECTRICAL	MECHANICAL	ENVIRONMENTAL
Frequency Range (GHz) DC to 67GHz	Recommended Mating force or Torque 0.9 N.m	Temperature Rating -40°C TO +85°C
Voltage Rating (Peak) @ Sea Level 335 VAC RMS	Mating cycles 500 cycles	
Insulation Resistance (MIN.) 5000 M ohms		
Contact Resistance (Milliohms MAX) Center Contact 3 Outer Contact 2	VSWR: 1.15 Max @ DC--40 GHz 1.20 Max @ 40--50 GHz	
Dielectric Withstand Voltage: 500 Volts RMS Max	RF-Leakage: N/A	
Insertion Loss : 0.05√F(GHz) dB	Intermodulation: N/A	

THIS DRAWING IS A CONTROLLED DOCUMENT.		DWN RZ 05 JUN 2018
DIMENSIONS: mm		CHK BW 05 JUN 2018
TOLERANCES UNLESS OTHERWISE SPECIFIED:		APVD RS 05 JUN 2018
0 PLC ± -		PRODUCT SPEC
1 PLC ± 0.2		---
2 PLC ± 0.1		APPLICATION SPEC
3 PLC ± -		---
4 PLC ± -		WEIGHT 0.000000
ANGLES ± -		CUSTOMER DRAWING
FINISH -		
MATERIAL SEE TABLE		

QUANTITY PER ASSY	MATERIAL	DESCRIPTION	ITEM
1	STEEL	NUT	5
1	SILICONE	GASKET	4
1	PEI	INSULATION	3
1	BeCu	CENTER CONTACT	2
1	STEEL	SHELL	1
-1			

STE TE Connectivity			
NAME ADAPTER 2.4mm MALE TO 1.85mm FEMALE			
SIZE	CAGE CODE	DRAWING NO	RESTRICTED TO
A3	00779	C-2081552	---
SCALE 5:1		SHEET 1 OF 1	REV A