

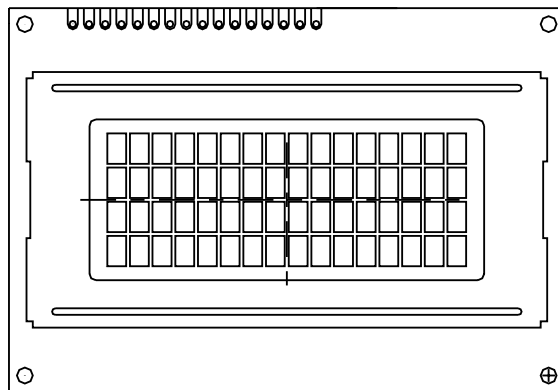

PRODUCT SPECIFICATION

# HDM16416H-S00S

16 CHARACTERS , 4 LINES  
LCD DISPLAY MODULE



HANTRONIX, INC. 10080 BUBB RD. CUPERTINO, CA 95014	Q.A.:	REV.:	HDM16416H-S00S	SHEET 1 OF 11
	Z.W.	1.0		DATE: 3/22/10

## ? ?General Specifications

### 1.Features

- A. Drive Method: 1/16 Duty, 1/5 Bias
- B. The Module Operating Voltage: 5.0V;
- C. The LCD Operating Voltage : 4.7V;
- D. Viewing Direction: 6:00
- E. Operating Temperature: 0°C ~50°C
- F. Storage Temperature: -20°C ~70°C
- G. Display type: STN mode, Positive type display

### 2.Mechanical Data and Conditions:

- (1) Module Size-----87.0 w \*60.0 h mm
- (2) Viewing Area ----- 61.8 w \* 25.2 h mm
- (3) Dot Size -----0.55 w \* 0.55 h mm
- (4) Character Size -----2.95 w \*4.75 h mm
- (5) Number of Characters -----16 Characters\*4 Line
- (6) Outline Dimensions-----See Attached Drawing `

HANTRONIX, INC. 10080 BUBB RD. CUPERTINO, CA 95014	Q.A.:	REV.:	HDM16416H-S00S	SHEET 2 OF 11
	Z.W.	1.0		DATE: 3/22/10

### 3.Pin Connections:

Pin No.	Symbol	Function
1	VSS	Ground(0v)
2	VDD	Logic Supply Voltage(+5.0v)
3	VEE	LCD Driver Voltage Input
4	RS	Data/Instruction Register Select
5	R/W	Read/Write Select
6	E	Enable Signal
7-14	DB0-DB7	Data Bus Line
15	LED+	LED Power
16	LED-	LED Power

### 4. Absolute Maximum Ratings

Characteristics	Symbol	Ratings	Unit	Note
Operating Voltage	VDD	-0.3 to +7.0	V	
Driver Supply Voltage	V <sub>LCD</sub>	VDD - 10 to VDD + 0.3	V	
Input Voltage Range	V <sub>IN</sub>	-0.3 to VDD + 0.3	V	

Note: Stresses beyond those given in the Absolute Maximum Rating table may cause operational errors or damage to the device. For normal operational conditions see AC/DC Electrical Characteristics.

HANTRONIX, INC. 10080 BUBB RD. CUPERTINO, CA 95014	Q.A.: Z.W.	REV.: 1.0	HDM16416H-S00S	SHEET 3 OF 11
				DATE: 3/22/10

## 5. Timing Characteristics:

### Write Operation Writing Data from MPU to SPLC780D1

Characteristics	Symbol	Limit			Unit	Test Condition
		Min.	Typ.	Max.		
E Cycle Time	$t_c$	400	-	-	ns	Pin E
E Pulse Width	$t_{PW}$	150	-	-	ns	Pin E
E Rise/Fall Time	$t_R, t_F$	-	-	25	ns	Pin E
Address Setup Time	$t_{SP1}$	30	-	-	ns	Pins: RS, R/W, E
Address Hold Time	$t_{HD1}$	10	-	-	ns	Pins: RS, R/W, E
Data Setup Time	$t_{SP2}$	40	-	-	ns	Pins: DB0 - DB7
Data Hold Time	$t_{HD2}$	10	-	-	ns	Pins: DB0 - DB7

### Write mode timing diagram Writing Data from MPU to SPLC780D1

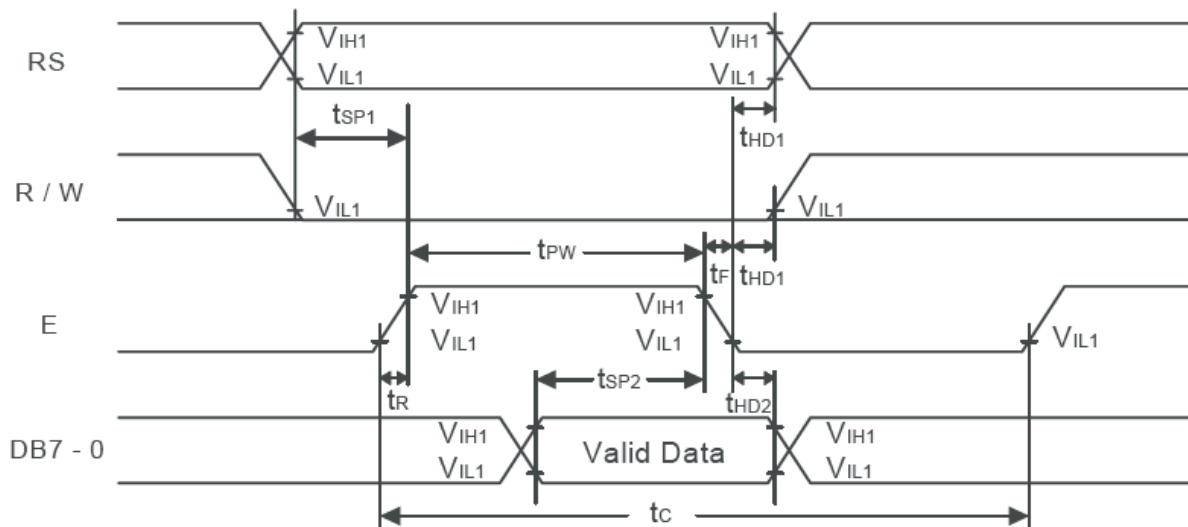

Read Operation    Reading Data from SPLC780D1 to MPU

Characteristics	Symbol	Limit			Unit	Test Condition
		Min.	Typ.	Max.		
E Cycle Time	$t_c$	400	-	-	ns	Pin E
E Pulse Width	$t_w$	150	-	-	ns	Pin E
E Rise/Fall Time	$t_r, t_f$	-	-	25	ns	Pin E
Address Setup Time	$t_{SP1}$	30	-	-	ns	Pins: RS, R/W, E
Address Hold Time	$t_{HD1}$	10	-	-	ns	Pins: RS, R/W, E
Data Output Delay Time	$t_d$	-	-	100	ns	Pins: DB0 - DB7
Data hold time	$t_{HD2}$	5.0	-	-	ns	Pin DB0 - DB7

Read mode timing diagram    Reading Data from SPLC780D1 to MPU

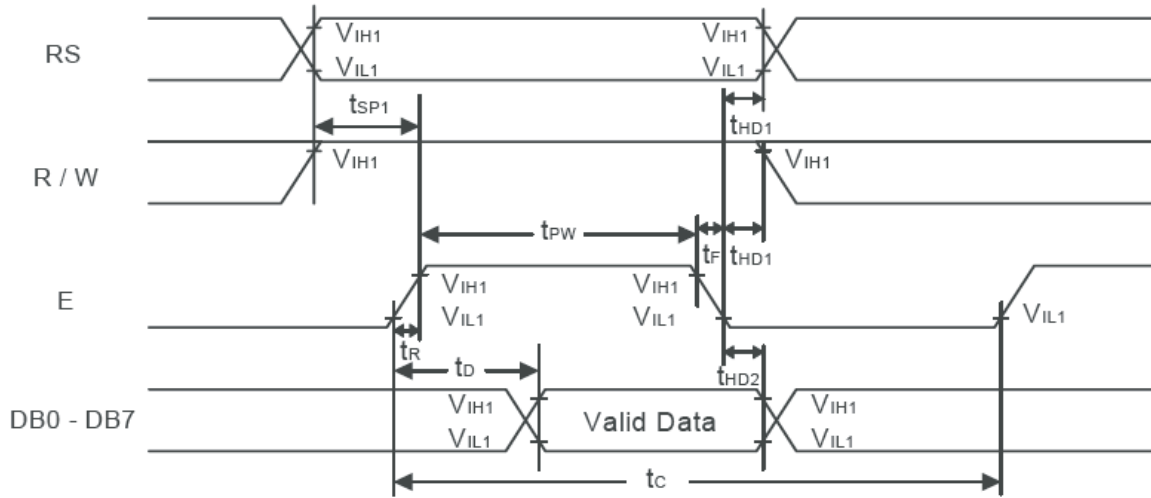

## .The Characteristics and The Reliability Test

### 1.Electro-Optic Characteristics:

Condition:TEMP=(23 ± 3) °C

NO	Item	Symbol	Min.	Typ.	Max.	Unit	Condition
1	Supply Voltage(Logic)	Vdd-Vss		5.0		V	
3	LCD Operating Voltage	Vdd-V <sub>0</sub>		4.9		V	0°C
				4.7		V	25°C
				4.5		V	50°C
4	Response Time	Ton		180		ms	
		Toff		212		ms	
5	Contrast	CR	2				
6	Viewing Angel	12H	1	50		Deg.	(CR ≥ 2.0)
		6H	2	65			
		3H	3	58			
		9H	4	58			

:

### 3. Reliability Test

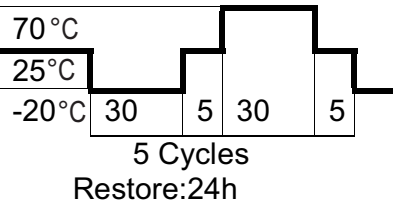
No	Items	Test Condition	Equipment	Test Result
1	High Temp Storage	Temp: $70 \pm 2^\circ\text{C}$ Time: 96h Restore: 24h	Tenny	Passed
2	Low Temp Storage	Temp: $-20 \pm 3^\circ\text{C}$ Time: 96h Restore: 24h	Tenny	Passed
3	High Temp Static drive	Temp: $50 \pm 2^\circ\text{C}$ Vop: 5V Time: 24h Restore: 24h	Tenny	Passed
4	Low Temp Static drive	Temp: $0 \pm 3^\circ\text{C}$ Vop: 5V Time: 24h Restore: 24h	Tenny	Passed
5	High Temp High Hum Storage	Temp: $40 \pm 2^\circ\text{C}$ Hum: 95%Rh Time: 96h Restore: 24h	Tenny	Passed
6	Thermal Shock	Temp: ( $^\circ\text{C}$ )  70 $^\circ\text{C}$ 25 $^\circ\text{C}$ -20 $^\circ\text{C}$ 30 5 30 5 5 Cycles Restore: 24h	Tenny	Passed

# The Equipment and LCD Measuring Method

## 1. Equipment

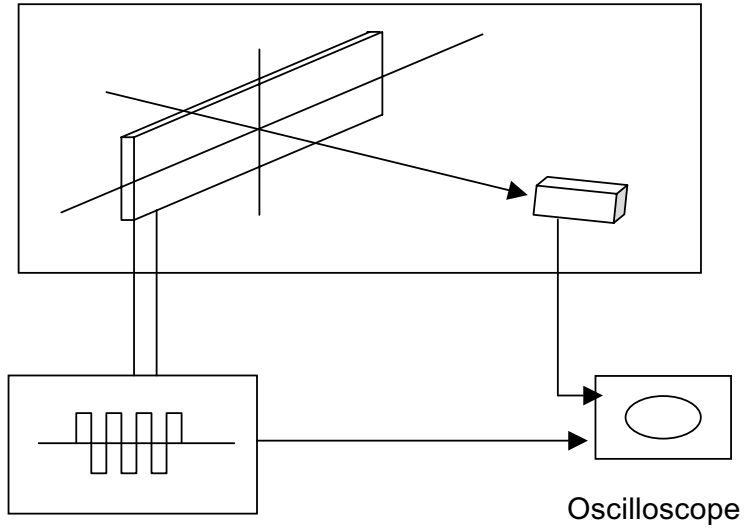

Waveform Generator

## (2) Definition

### a. Threshold Voltage ( $V_{th}$ )

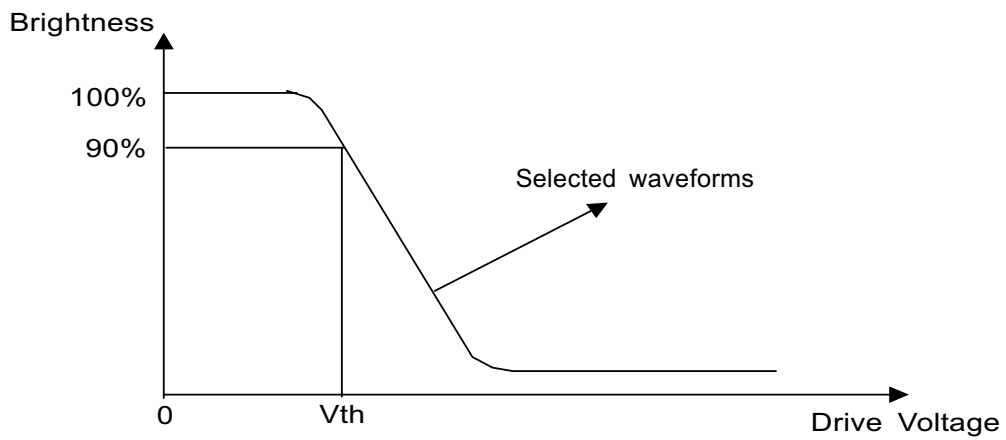



b. Response Time

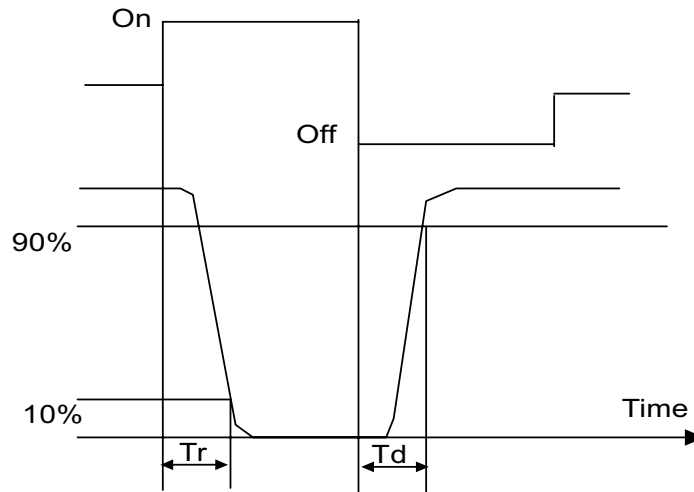

a. Viewing Angle:

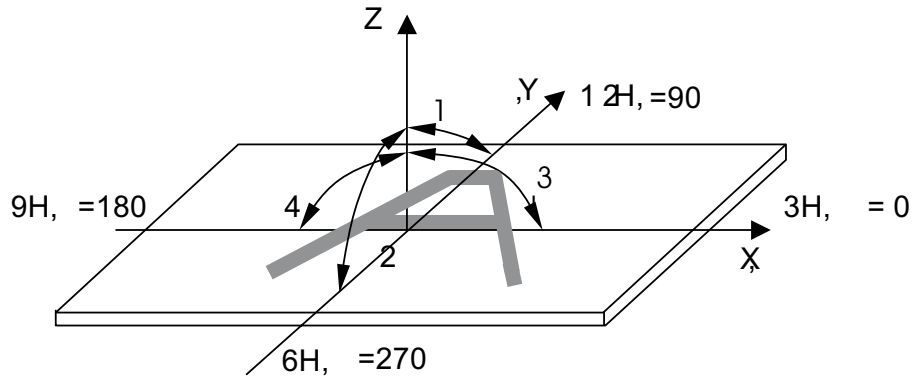

b. Contrast Ratio (positive)

$$CR = \frac{\text{Brightness of non-selected wave-form}}{\text{Brightness of selected wave-form}}$$

4. Reliability Test:

Equipment : Tenny

HANTRONIX, INC. 10080 BUBB RD. CUPERTINO, CA 95014	Q.A.:	REV.:	HDM16416H-S00S	SHEET 9 OF 11
	Z.W.	1.0		DATE: 3/22/10

.Attached Drawing

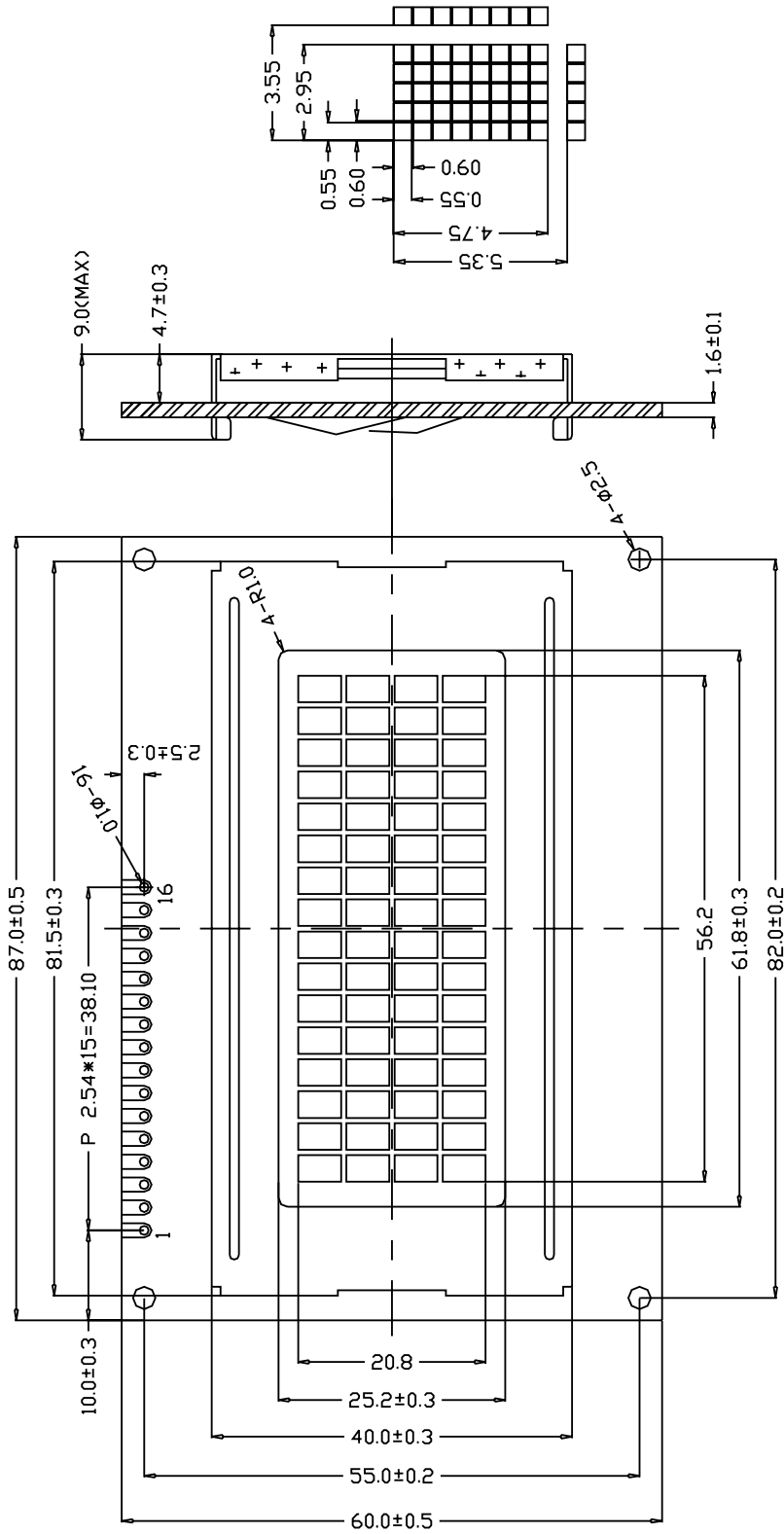

- Note:
1. Operating Voltage: 5V
  2. Drive method: 1/16Duty, 1/5 Bias
  3. Viewing Direction: 6:00
  4. Operating Temp: 0°C~50°C
  5. Storage Temp: -20°C~70°C
  6. Display type: STN,Positive

HANTRONIX, INC.  
10080 BUBB RD.  
CUPERTINO, CA 95014

Q.A.:  
Z.W.

REV.:  
1.0

HDM16416H-S00S

SHEET 10 OF 11

DATE:  
3/22/10

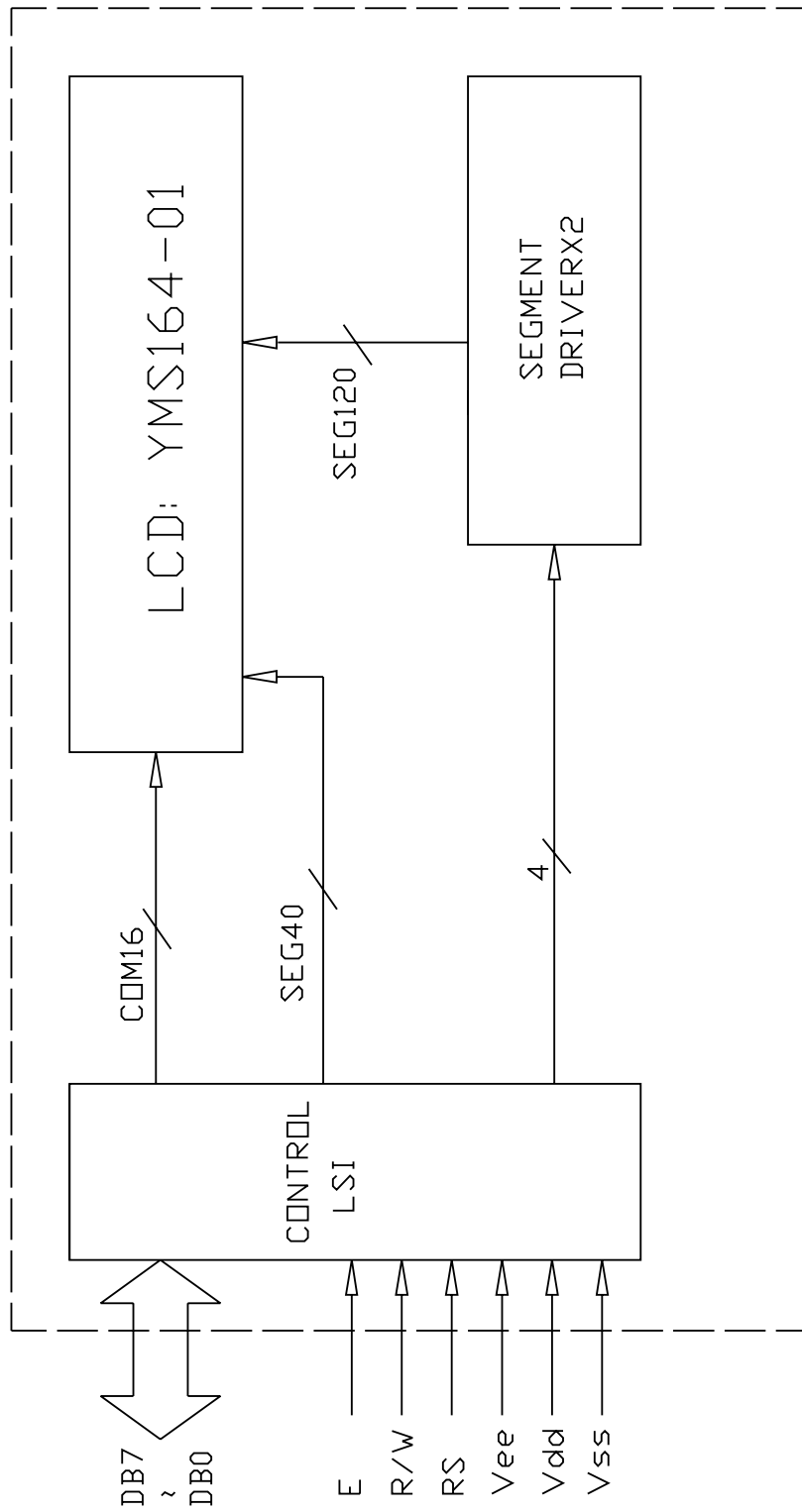

PIN NO.	1	2	3	4	5	6	7	8	9	10	11	12	13	14	15	16
SYMBOL	Vss	Vdd	Vee	RS	R/W	E	DB0	DB1	DB2	DB3	DB4	DB5	DB6	DB7	LED+	LED-

HANTRONIX, INC.  
 10080 BUBB RD.  
 CUPERTINO, CA 95014

Q.A.:  
 Z.W.

REV.:  
 1.0

**HDM16416H-S00S**

SHEET 11 OF 11  
 DATE: 3/22/10