

# 10 channel in QFN Small Package 10 bit D/A Converters

## BU22210MUV

### General Description

BU22210MUV includes 10 channels D/A converters which is high performance 10bit R-2R-type. It is most suitable for applications which have many adjustment items, because it is small size and has many D/A converter channels.

Input is serial data transfer system with the DI, CLK and CSB terminal, and output is DO terminal enabling a cascade connection.

A built-in Initial-Zero-Hold function ensures that the output voltage of all channels are Low during power up, so that it is able to reduce parts for measure against malfunction. And wide supply voltage range from 2.7V - 5.5V has flexibility to specification change.

### Features

- Built-in 10-channel 10bit D/A converters.
- Built-in Rail-to-rail output buffer.
- 3-wire serial interface (16 bit data).
- Cascade Connection is available.
- Built-in Initial-Zero-Hold function.
- QFN Small package (0.5mm pitch).

### Applications

- The various types of consumer (ex. Printer, DSC and more).

### Key Specifications

- Operating Supply Voltage Range: 2.7V to 5.5V
- Current Consumption: 1.2mA(Typ)
- Differential Non Linearity Error:  $\pm 0.5\text{LSB}$
- Integral Non Linearity Error:  $\pm 2.0\text{LSB}$
- Output Current Capability:  $\pm 1.0\text{mA}$
- Data Transfer Frequency: 10MHz(Max)
- Operating Temperature Range:  $-20^{\circ}\text{C}$  to  $+85^{\circ}\text{C}$

### Package

VQFN016V3030

W(Typ) x D(Typ) x H(Max)

3.00mm x 3.00mm x 1.00mm

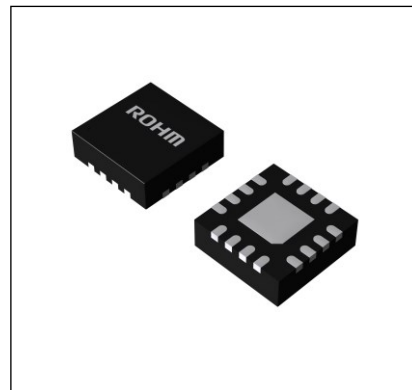

### Typical Application Circuit

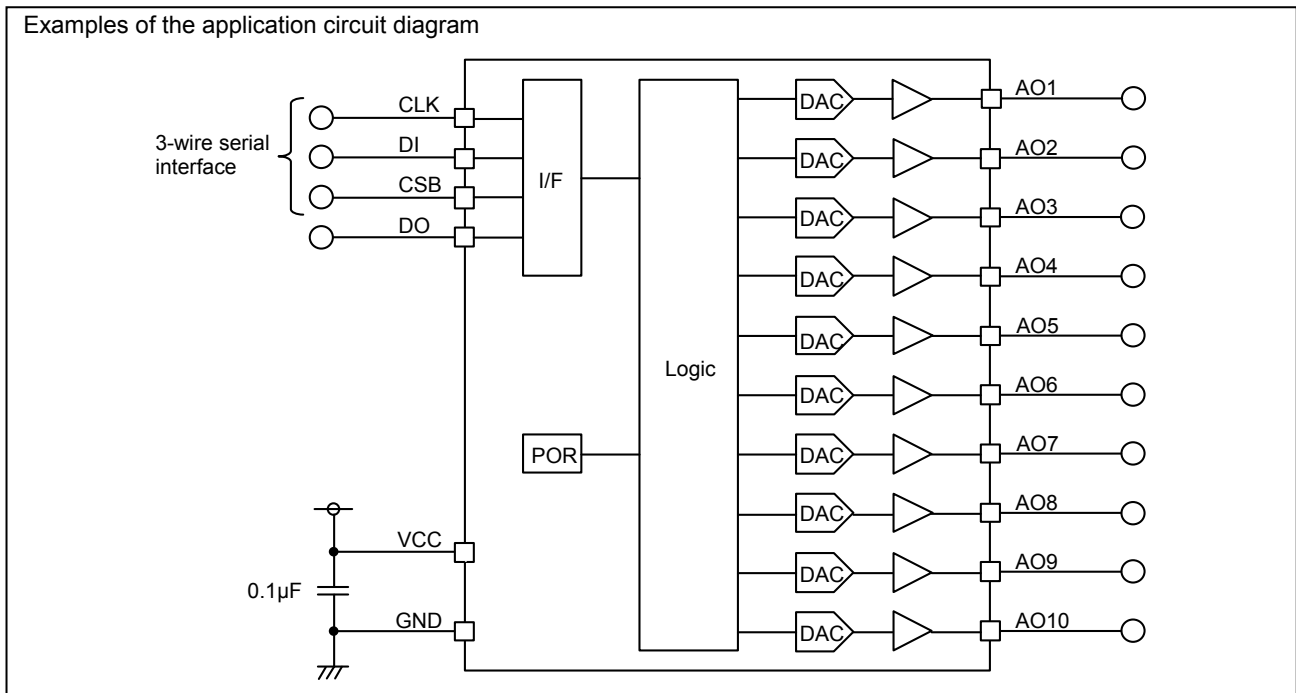

## Contents

General Description .....	1
Features .....	1
Applications .....	1
Key Specifications .....	1
Package .....	1
Typical Application Circuit .....	1
Pin Configuration .....	3
Pin Descriptions .....	3
Block Diagram .....	3
Absolute Maximum Ratings .....	4
Thermal Resistance .....	4
Recommended Operating Conditions .....	5
Electrical Characteristics .....	5
Typical Performance Curves .....	6
Figure 1. Supply Current vs Supply Voltage .....	6
Figure 2. Supply Current vs Temperature .....	6
Figure 3. Supply Current vs Supply Voltage .....	6
Figure 4. Supply Current vs Temperature .....	6
Figure 5. DNL vs Digital Input Code .....	7
Figure 6. INL vs Digital Input Code .....	7
Figure 7. Max absolute value of DNL vs Supply Voltage .....	7
Figure 8. Max absolute value of INL vs Supply Voltage .....	7
Figure 9. Max absolute value of DNL vs Temperature .....	8
Figure 10. Max absolute value of INL vs Temperature .....	8
Timing Chart .....	9
Communication Format .....	10
Register Map .....	10
Cascade Connection .....	12
Power supply power-up sequence .....	13
I/O Equivalent Circuits .....	14
Operational Notes .....	15
Ordering Information .....	17
Marking Diagrams .....	17
Physical Dimension, Tape and Reel Information .....	18
Revision History .....	19

Pin Configuration

TOP VIEW  
(Pads not visible)

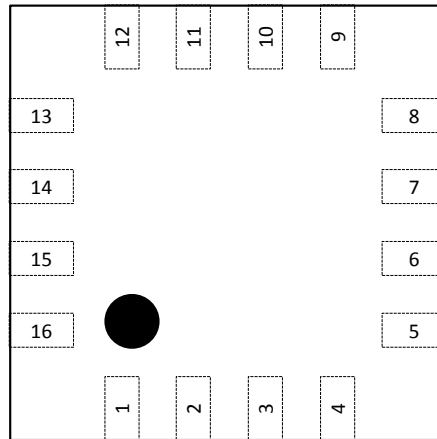

Pin Descriptions

Pin No.	Pin Name	Function
1	AO10	Analog output ch10
2	GND	Ground
3	VCC	Power Supply <sup>(Note 1)</sup>
4	AO1	Analog output ch1
5	AO2	Analog output ch2
6	AO3	Analog output ch3
7	AO4	Analog output ch4
8	AO5	Analog output ch5
9	DO	Serial output (DO outputs DI signal with 16 clock cycle delay)
10	CLK	Serial clock input
11	DI	Serial data input
12	CSB	Chip select input
13	AO6	Analog output ch6
14	AO7	Analog output ch7
15	AO8	Analog output ch8
16	AO9	Analog output ch9

(Note 1) Please implement the bypass condenser near ICs.

Block Diagram

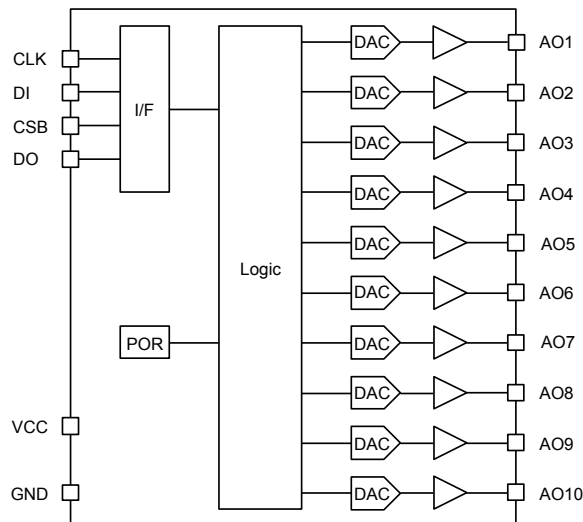

## Absolute Maximum Ratings (Ta = 25°C)

Parameter	Symbol	Rating	Unit
Power Supply Voltage	V <sub>CC</sub>	+7	V
Terminal Voltage	V <sub>IN</sub>	-0.3 to +(V <sub>CC</sub> +0.3) or +7 Whichever is less	V
Storage Temperature Range	T <sub>stg</sub>	-40 to +125	°C
Maximum Junction Temperature	T <sub>jmax</sub>	125	°C

**Caution 1:** Operating the IC over the absolute maximum ratings may damage the IC. The damage can either be a short circuit between pins or an open circuit between pins and the internal circuitry. Therefore, it is important to consider circuit protection measures, such as adding a fuse, in case the IC is operated over the absolute maximum ratings.

**Caution 2:** Should by any chance the maximum junction temperature rating be exceeded the rise in temperature of the chip may result in deterioration of the properties of the chip. In case of exceeding this absolute maximum rating, increase the board size and copper area to prevent exceeding the maximum junction temperature rating.

Thermal Resistance<sup>(Note 2)</sup>

Parameter	Symbol	Thermal Resistance (Typ)		Unit
		1s <sup>(Note 4)</sup>	2s2p <sup>(Note 5)</sup>	
VQFN016V3030				
Junction to Ambient	θ <sub>JA</sub>	189.0	57.5	°C/W
Junction to Top Characterization Parameter <sup>(Note 3)</sup>	Ψ <sub>JT</sub>	23	10	°C/W

(Note 2)Based on JESD51-2A(Still-Air).

(Note 3)The thermal characterization parameter to report the difference between junction temperature and the temperature at the top center of the outside surface of the component package.

(Note 4)Using a PCB board based on JESD51-3.

Layer Number of Measurement Board	Material	Board Size
Single	FR-4	114.3mm x 76.2mm x 1.57mmt
Top		
Copper Pattern	Thickness	
Footprints and Traces	70μm	

(Note 5)Using a PCB board based on JESD51-5, 7.

Layer Number of Measurement Board	Material	Board Size	Thermal Via <sup>(Note 6)</sup>		
			Pitch	Diameter	
4 Layers	FR-4	114.3mm x 76.2mm x 1.6mmt	1.20mm	Φ0.30mm	
Top		2 Internal Layers		Bottom	
Copper Pattern	Thickness	Copper Pattern	Thickness	Copper Pattern	Thickness
Footprints and Traces	70μm	74.2mm x 74.2mm	35μm	74.2mm x 74.2mm	70μm

(Note 6) This thermal via connects with the copper pattern of all layers.

## Recommended Operating Conditions

Parameter	Symbol	Min	Typ	Max	Unit
Power Source Voltage	$V_{CC}$	2.7	-	5.5	V
Terminal Input Voltage Range <sup>(Note 7)</sup>	$V_{IN}$	0	-	$V_{CC}$	V
Analog Output Current <sup>(Note 8)</sup>	$I_{OUT}$	-1.0	-	+1.0	mA
Serial Clock Frequency <sup>(Note 9)</sup>	$f_{CLK}$	-	1.0	10.0	MHz
Load Capacitance Limit <sup>(Note 8)</sup>	$C_L$	-	-	1500	pF
Operating Temperature	$T_{opr}$	-20	+25	+85	°C

(Note 7) CLK, DI, CSB.

(Note 8) AO1, AO2, AO3, AO4, AO5, AO6, AO7, AO8, AO9, AO10.

(Note 9) CLK.

Electrical Characteristics (Unless otherwise specified  $V_{CC}=3.0V$   $T_a=25^\circ C$ )

Parameter	Symbol	Min	Typ	Max	Unit	Conditions
<Current Consumption>						
Current Consumption	$I_{CC}$	-	1.2	2.5	mA	Logic input : GND or $V_{CC}$
Power Down Current	$I_{PD}$	-	2	10	$\mu A$	Power Down mode
<Logic Interface>						
L input Voltage	$V_{IL}$	GND	-	0.6	V	$V_{CC}=2.7V$ to $3.6V$
		GND	-	0.8	V	$V_{CC}=4.5V$ to $5.5V$
H input Voltage	$V_{IH}$	2.1	-	$V_{CC}$	V	$V_{CC}=2.7V$ to $3.6V$
		2.4	-	$V_{CC}$	V	$V_{CC}=4.5V$ to $5.5V$
Input Current	$I_{IN}$	-10	-	+10	$\mu A$	
Low output Voltage	$V_{OL}$	GND	-	$0.2 \cdot V_{CC}$	V	$I_{SINK}=1mA$
High output Voltage	$V_{OH}$	$0.8 \cdot V_{CC}$	-	$V_{CC}$	V	$I_{SOURCE}=1mA$
Output Load Current	$I_{OL}$	-1.0	-	+1.0	mA	
<Buffer Amplifier>						
Output Zero Scale Voltage	$V_{ZS1}$	GND	-	0.1	V	000h setting, no load
	$V_{ZS2}$	GND	-	0.3	V	000h setting, $I_{SINK}=1.0mA$
Output Full Scale Voltage	$V_{FS1}$	$V_{CC}-0.1$	-	$V_{CC}$	V	3FFh setting, no load
	$V_{FS2}$	$V_{CC}-0.3$	-	$V_{CC}$	V	3FFh setting, $I_{SOURCE}=1.0mA$
<D/A Converter Precision>						
Differential Non Linearity Error	DNL	-0.5	-	+0.5	LSB	Input code 008h to 3F7h
Integral Non Linearity Error	INL	-2.0	-	+2.0	LSB	Input code 008h to 3F7h

Typical Performance Curves

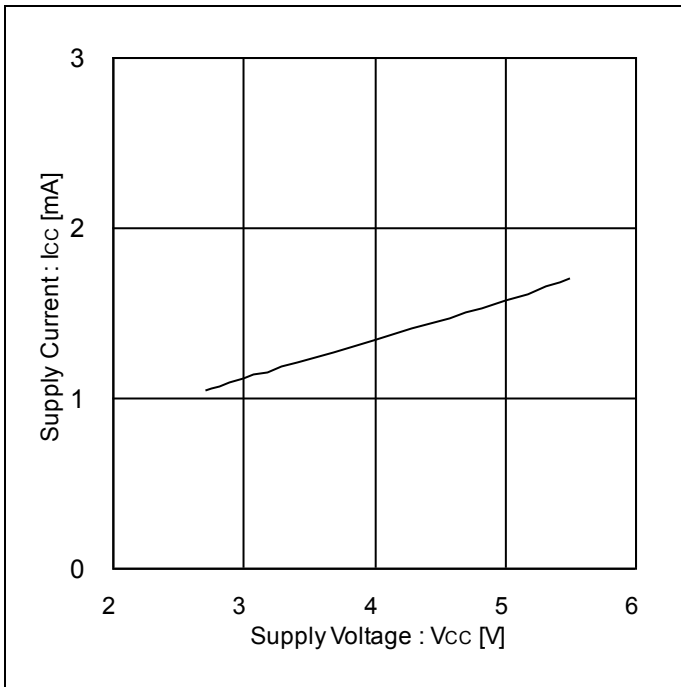

Figure 1. Supply Current vs Supply Voltage  
("Active Current Consumption", Ta=25°C, Code=200h)

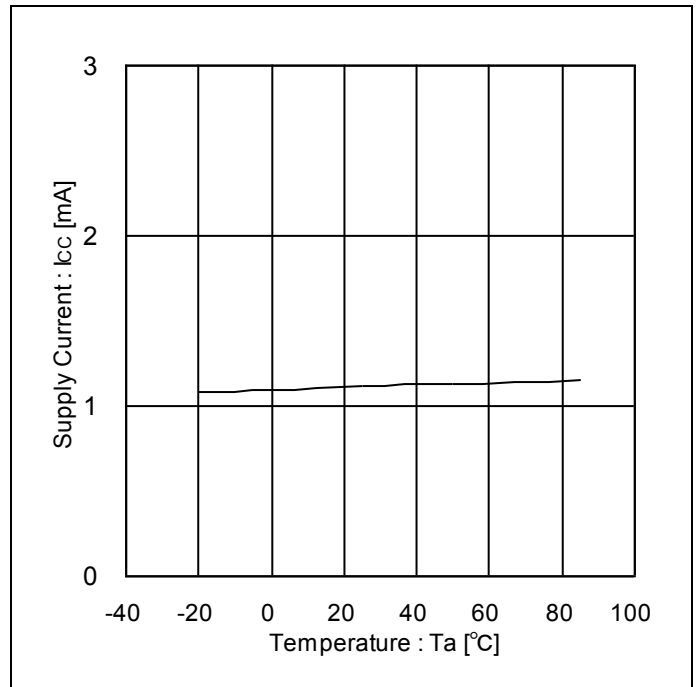

Figure 2. Supply Current vs Temperature  
("Active Current Consumption", Vcc=3.0V, Code=200h)

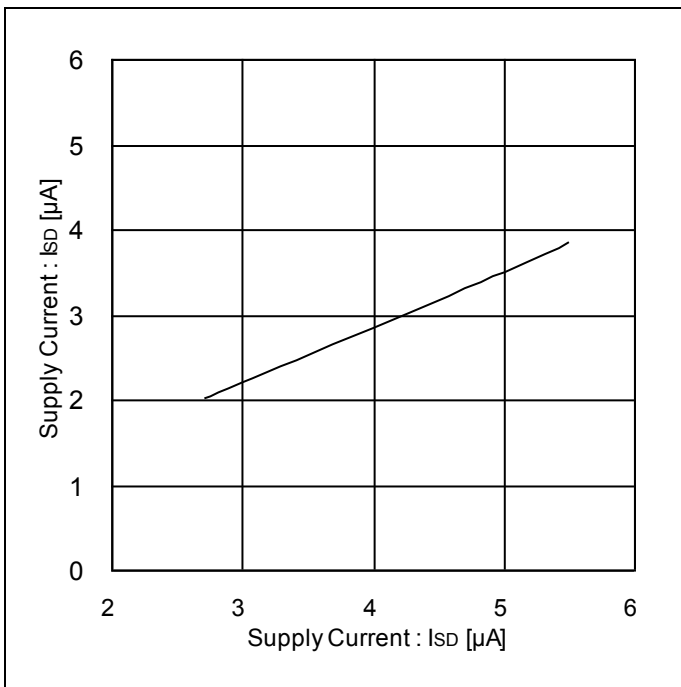

Figure 3. Supply Current vs Supply Voltage  
("Power-down Current", Ta=25°C)

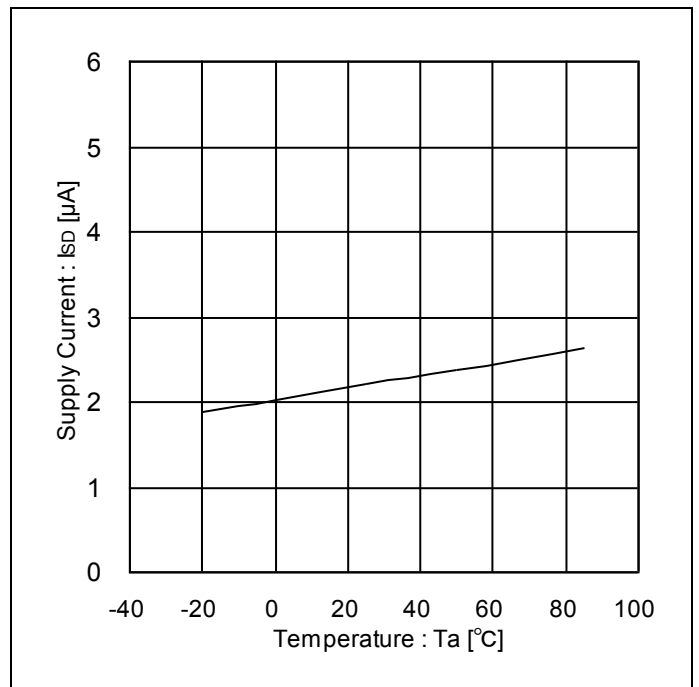

Figure 4. Supply Current vs Temperature  
("Power-down Current", Vcc=3.0V)

Typical Performance Curves - continued

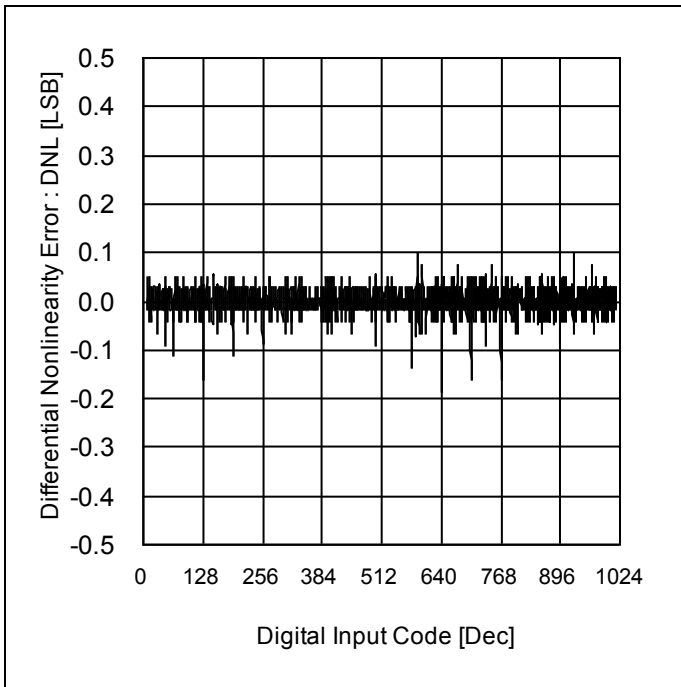

Figure 5. DNL vs Digital Input Code  
("Differential Nonlinearity Error",  $V_{cc}=3.0V, T_a=25^{\circ}C$ )

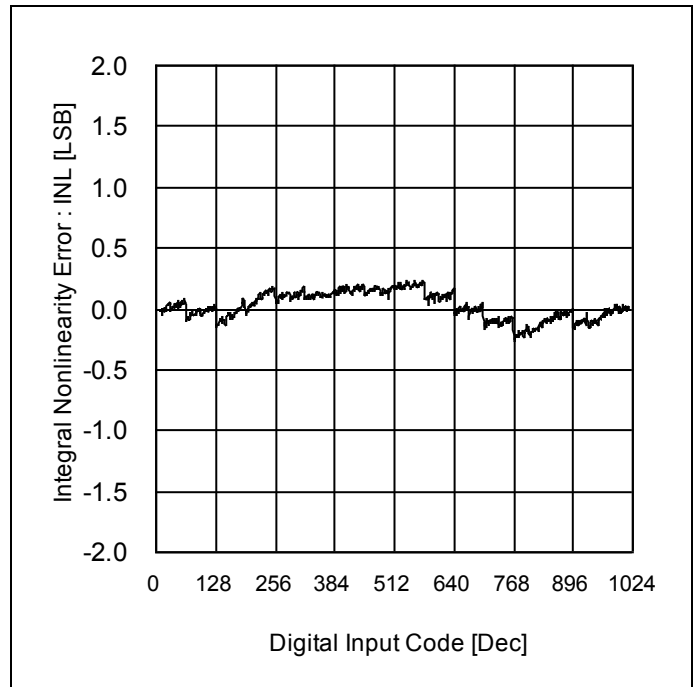

Figure 6. INL vs Digital Input Code  
("Integral Nonlinearity Error ",  $V_{cc}=3.0V, T_a=25^{\circ}C$ )

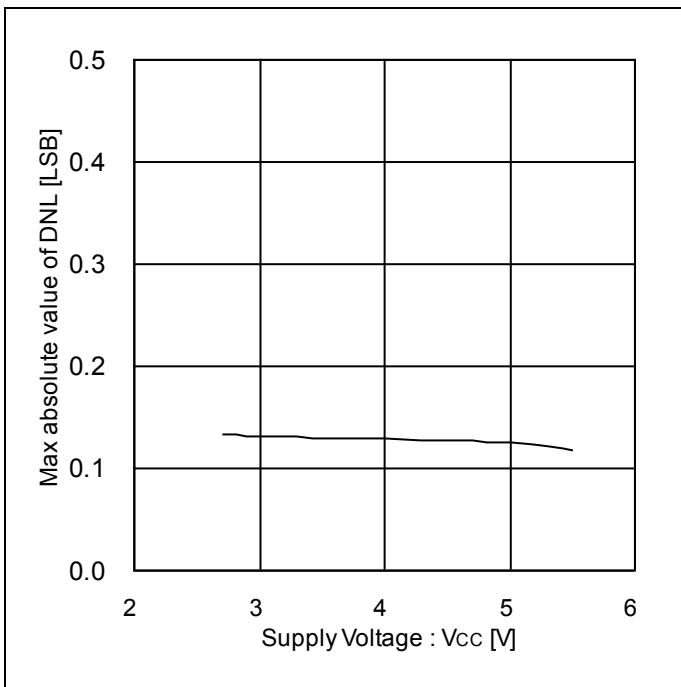

Figure 7. Max absolute value of DNL vs Supply Voltage  
("Differential Nonlinearity Error",  $T_a=25^{\circ}C$ )

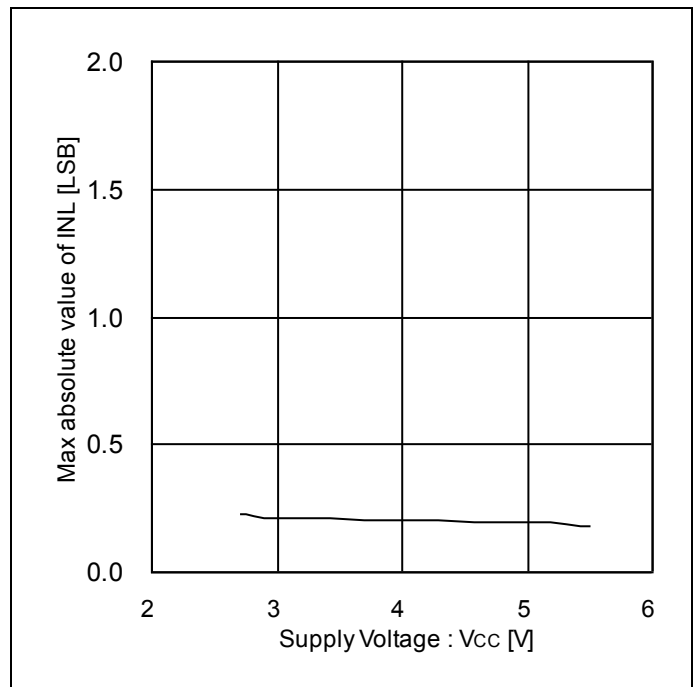

Figure 8. Max absolute value of INL vs Supply Voltage  
("Integral Nonlinearity Error",  $T_a=25^{\circ}C$ )

Typical Performance Curves - continued

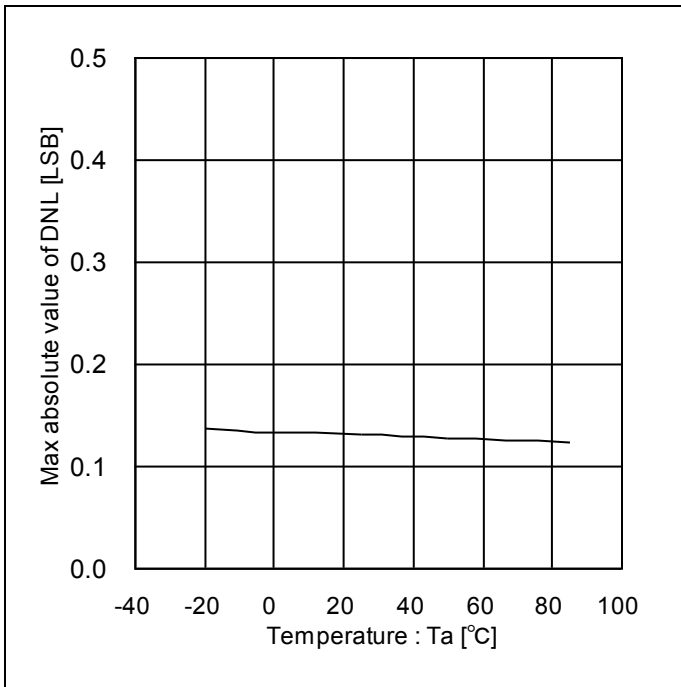

Figure 9. Max absolute value of DNL vs Temperature ("Differential Nonlinearity Error", Vcc=3.0V)

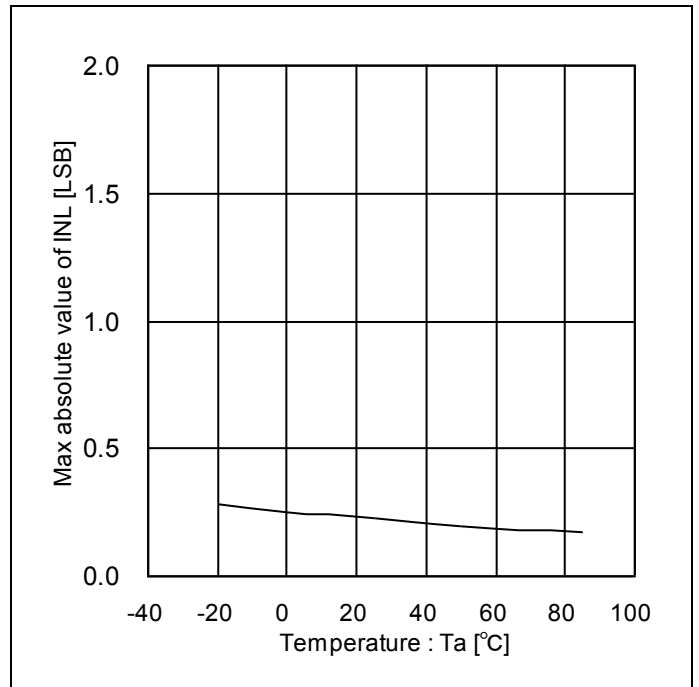

Figure 10. Max absolute value of INL vs Temperature ("Integral Nonlinearity Error", Vcc=3.0V)



Timing Chart

(Unless otherwise specified  $V_{CC}=3.0V$ ,  $R_L=OPEN$ ,  $C_L=0pF$ ,  $T_a=25^{\circ}C$ )

Parameter	Symbol	Limit			Unit	Conditions
		Min	Typ	Max		
CLK L Level Period	$t_{CLK\_L}$	50	-	-	ns	
CLK H Level Period	$t_{CLK\_H}$	50	-	-	ns	
DI Setup Time	$t_{S\_DI}$	20	-	-	ns	
DI Hold Time	$t_{H\_DI}$	40	-	-	ns	
CSB Setup Time	$t_{S\_CSB}$	50	-	-	ns	
CSB Hold Time	$t_{H\_CSB}$	50	-	-	ns	
CSB H Level Period	$t_{CSB\_H}$	50	-	-	ns	

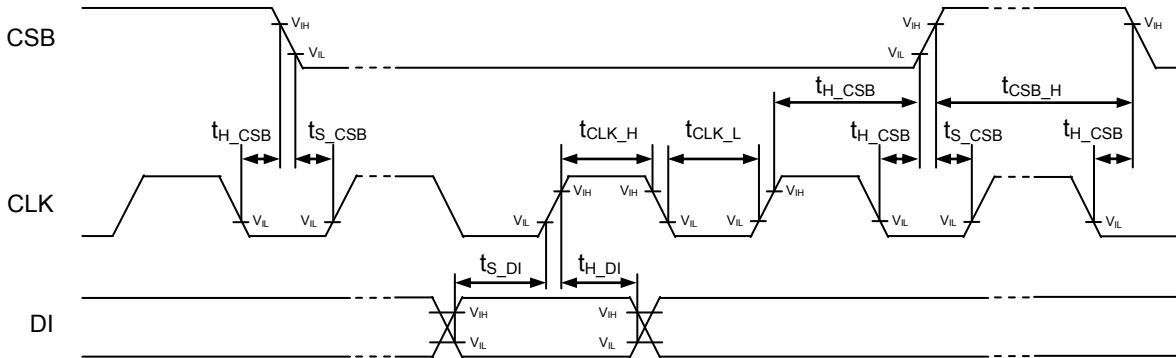

Figure 11. Timing chart

**Communication Format**

The Serial Control Interface is 3-wire serial interface 1) CSB, 2) CLK and 3) DI.

Every command is composed of 16 bits data sent through DI line (MSB first).

DI data is read every rising edge of the CLK while CSB is LOW.

Last 16 bits of data are latched when CSB goes HIGH.

The DO outputs the data of the most significant bit at a falling edge of CLK after 16 clocks delay.

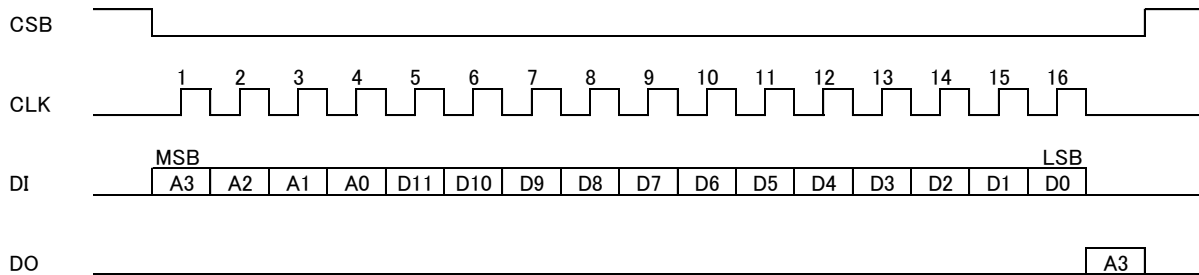

Figure 12. Communication Format

**Register Map** (Note 10)

Register Address	Register Name	R/W	D11	D10	D9	D8	D7	D6	D5	D4	D3	D2	D1	D0
0x1	CH1 D/A	W	CH1 D/A DATA[9:0]										0	0
0x2	CH2 D/A	W	CH2 D/A DATA[9:0]										0	0
0x3	CH3 D/A	W	CH3 D/A DATA[9:0]										0	0
0x4	CH4 D/A	W	CH4 D/A DATA[9:0]										0	0
0x5	CH5 D/A	W	CH5 D/A DATA[9:0]										0	0
0x6	CH6 D/A	W	CH6 D/A DATA[9:0]										0	0
0x7	CH7 D/A	W	CH7 D/A DATA[9:0]										0	0
0x8	CH8 D/A	W	CH8 D/A DATA[9:0]										0	0
0x9	CH9 D/A	W	CH9 D/A DATA[9:0]										0	0
0xA	CH10 D/A	W	CH10 D/A DATA[9:0]										0	0
0xB	PD ENABLE	W	0	0	POWER DOWN ENABLE[9:0]									

(Note 10) Do not write any commands to other addresses except above. Do not write '1' to the fields in which value is '0' in above table.

## ( 0x1 to 0xA ) CHx D/A

Fields	Function
CH1 D/A DATA [9:0]	D/A Code Setting of AO1
CH2 D/A DATA [9:0]	D/A Code Setting of AO2
CH3 D/A DATA [9:0]	D/A Code Setting of AO3
CH4 D/A DATA [9:0]	D/A Code Setting of AO4
CH5 D/A DATA [9:0]	D/A Code Setting of AO5
CH6 D/A DATA [9:0]	D/A Code Setting of AO6
CH7 D/A DATA [9:0]	D/A Code Setting of AO7
CH8 D/A DATA [9:0]	D/A Code Setting of AO8
CH9 D/A DATA [9:0]	D/A Code Setting of AO9
CH10 D/A DATA [9:0]	D/A Code Setting of AO10
D/A Code Setting of each channel	0x000 : Vcc / 1024 x 0 0x001 : Vcc / 1024 x 1 : 0x3FE : Vcc / 1024 x 1022 0x3FF : Vcc / 1024 x 1023

default value 0x000

## ( 0xB ) PD ENABLE

Fields	Function
POWER DOWN ENABLE [9:0]	Turn a selected channel off. [0]:CH1, [1]:CH2, [2]:CH3, [3]:CH4, [4]:CH5, [5]:CH6, [6]:CH7, [7]:CH8, [8]:CH9, [9]:CH10 0 : Active 1 : Power Down

default value 0x000

**Cascade Connection**

This IC can control multiple BU22210MUVs with one serial interface line by connecting a DO pin to the data input pin (DI) of the next IC. The example of three BU22210MUVs cascade connection is shown in Figure 13, and the communication format in Figure 14.

CLK and CSB are commonly connected to all ICs. And about data line, connect the DO of #1 to the DI of #2, and connect the DO of #2 to the DI of #3.

Regarding command, make CSB Low, and send 16bit x 3 data from the data for #3, then make CSB High.

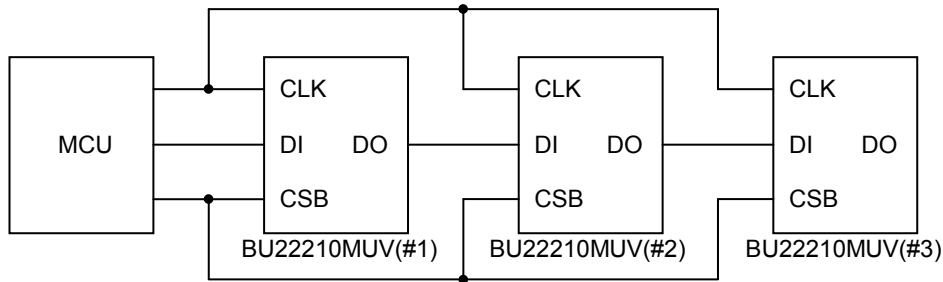

Figure 13. Example configuration of three BU22210MUVs cascade connection

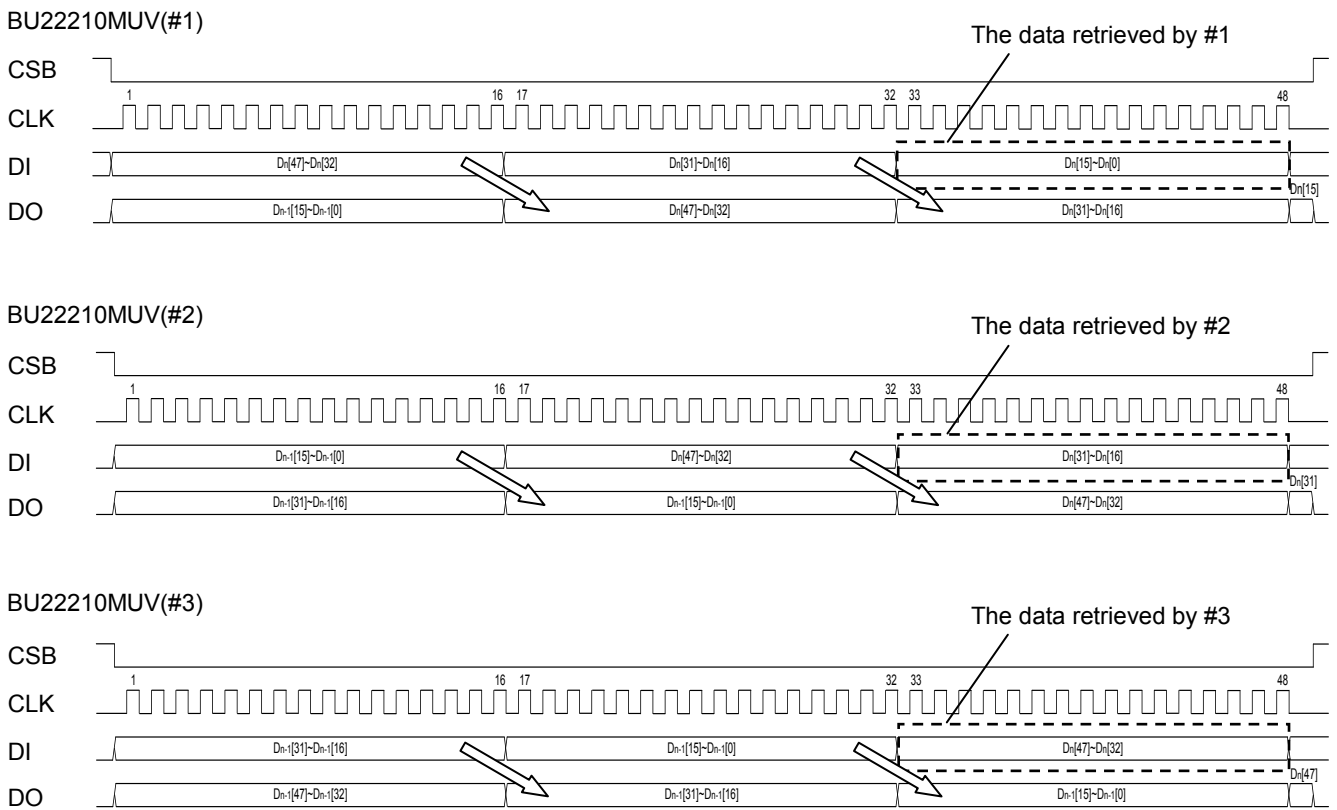
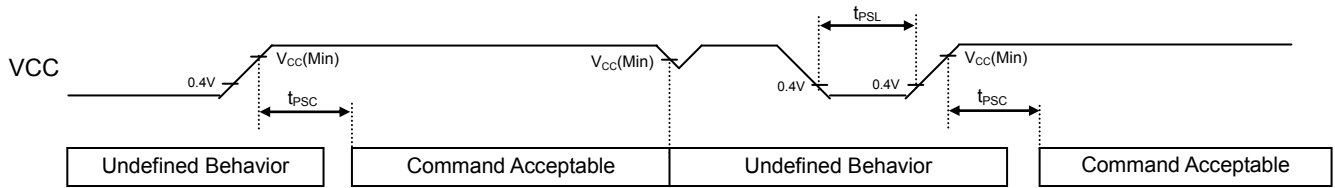

Figure 14. Communication Format of three BU22210MUVs cascade connection

Power supply power-up sequence (Unless otherwise specified  $V_{CC}=3.0V, T_a=25^{\circ}C$ )



Parameter	Symbol	Min	Typ	Max	Unit	Conditions
Command input wait time after power-up	$t_{PSC}$	100	-	-	$\mu s$	
Power-off time	$t_{PSL}$	1	-	-	ms	

Command input is available “ $t_{PSC}$ ” after VCC is supplied.

When VCC is below a recommended operating voltage range, the IC becomes undefined behavior state. In such case, power off, and power up again.

VCC voltage should keep being less than 0.4V for more than  $t_{PSL}$ , before supplying power to VCC.

I/O Equivalent Circuits

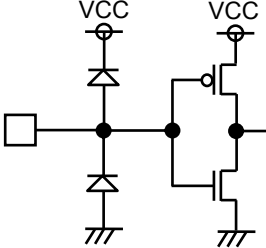
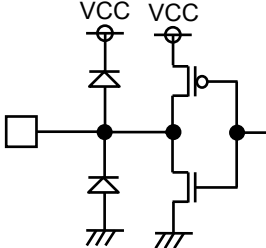
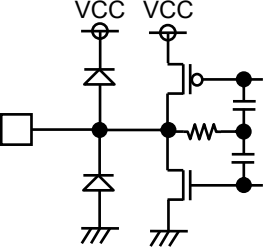
Pin Name	Equivalent Circuit Diagram	Pin Name	Equivalent Circuit Diagram
CLK DI CSB		DO	
AO1 AO2 AO3 AO4 AO5 AO6 AO7 AO8 AO9 AO10			

## Operational Notes

### 1. Reverse Connection of Power Supply

Connecting the power supply in reverse polarity can damage the IC. Take precautions against reverse polarity when connecting the power supply, such as mounting an external diode between the power supply and the IC's power supply pins.

### 2. Power Supply Lines

Design the PCB layout pattern to provide low impedance supply lines. Furthermore, connect a capacitor to ground at all power supply pins. Consider the effect of temperature and aging on the capacitance value when using electrolytic capacitors.

### 3. Ground Voltage

Ensure that no pins are at a voltage below that of the ground pin at any time, even during transient condition.

### 4. Ground Wiring Pattern

When using both small-signal and large-current ground traces, the two ground traces should be routed separately but connected to a single ground at the reference point of the application board to avoid fluctuations in the small-signal ground caused by large currents. Also ensure that the ground traces of external components do not cause variations on the ground voltage. The ground lines must be as short and thick as possible to reduce line impedance.

### 5. Recommended Operating Conditions

The function and operation of the IC are guaranteed within the range specified by the recommended operating conditions. The characteristic values are guaranteed only under the conditions of each item specified by the electrical characteristics.

### 6. Inrush Current

When power is first supplied to the IC, it is possible that the internal logic may be unstable and inrush current may flow instantaneously due to the internal powering sequence and delays, especially if the IC has more than one power supply. Therefore, give special consideration to power coupling capacitance, power wiring, width of ground wiring, and routing of connections.

### 7. Operation Under Strong Electromagnetic Field

Operating the IC in the presence of a strong electromagnetic field may cause the IC to malfunction.

### 8. Testing on Application Boards

When testing the IC on an application board, connecting a capacitor directly to a low-impedance output pin may subject the IC to stress. Always discharge capacitors completely after each process or step. The IC's power supply should always be turned off completely before connecting or removing it from the test setup during the inspection process. To prevent damage from static discharge, ground the IC during assembly and use similar precautions during transport and storage.

**Operational Notes – continued****9. Inter-pin Short and Mounting Errors**

Ensure that the direction and position are correct when mounting the IC on the PCB. Incorrect mounting may result in damaging the IC. Avoid nearby pins being shorted to each other especially to ground, power supply and output pin. Inter-pin shorts could be due to many reasons such as metal particles, water droplets (in very humid environment) and unintentional solder bridge deposited in between pins during assembly to name a few.

**10. Unused Input Pins**

Input pins of an IC are often connected to the gate of a MOS transistor. The gate has extremely high impedance and extremely low capacitance. If left unconnected, the electric field from the outside can easily charge it. The small charge acquired in this way is enough to produce a significant effect on the conduction through the transistor and cause unexpected operation of the IC. So unless otherwise specified, unused input pins should be connected to the power supply or ground line.

**11. Regarding the Input Pin of the IC**

In the construction of this IC, P-N junctions are inevitably formed creating parasitic diodes or transistors. The operation of these parasitic elements can result in mutual interference among circuits, operational faults, or physical damage. Therefore, conditions which cause these parasitic elements to operate, such as applying a voltage to an input pin lower than the ground voltage should be avoided. Furthermore, do not apply a voltage to the input pins when no power supply voltage is applied to the IC. Even if the power supply voltage is applied, make sure that the input pins have voltages within the values specified in the electrical characteristics of this IC.

**12. Ceramic Capacitor**

When using a ceramic capacitor, determine a capacitance value considering the change of capacitance with temperature and the decrease in nominal capacitance due to DC bias and others.



Ordering Information

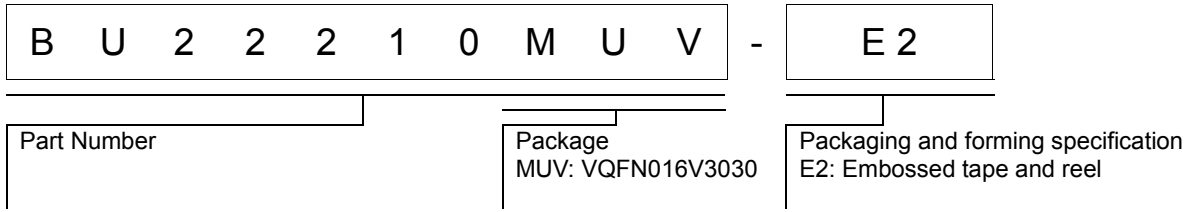

Marking Diagrams

VQFN016V3030(TOP VIEW)

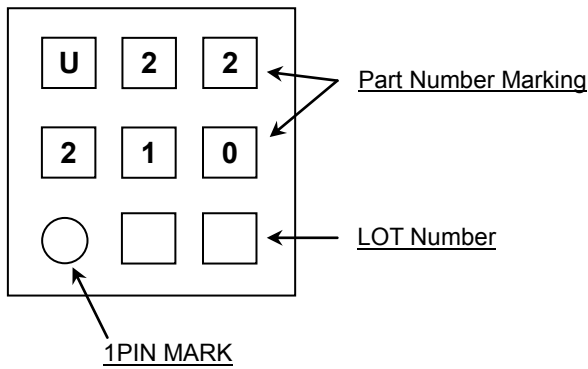

Physical Dimension, Tape and Reel Information

Package Name	VQFN016V3030
--------------	--------------

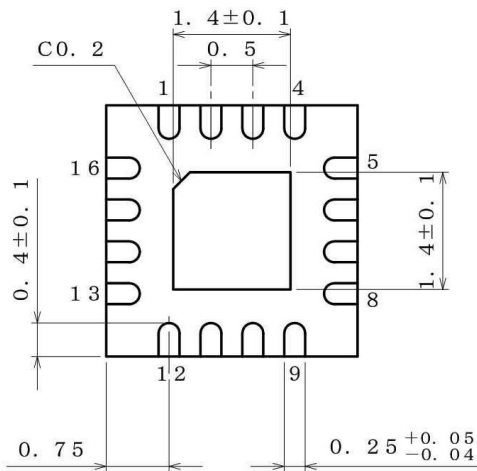
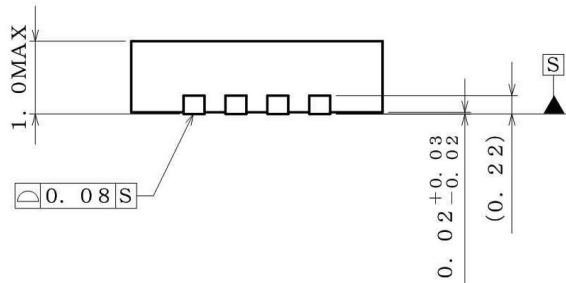
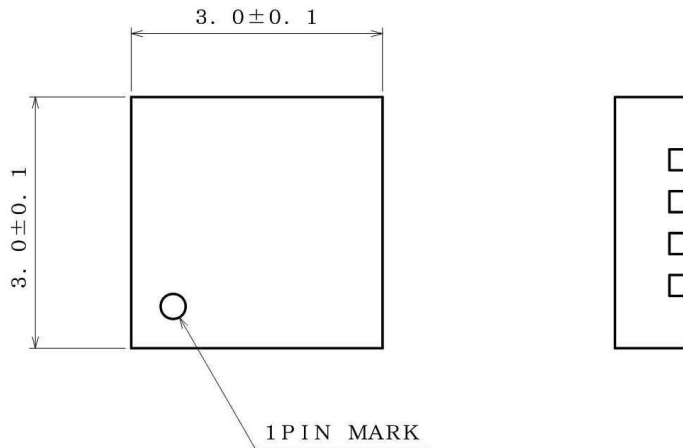

(UNIT : mm)

PKG : VQFN016V3030

Drawing No. EX460-5001-2

**<Tape and Reel information>**

Tape	Embossed carrier tape
Quantity	3000pcs
Direction of feed	E2 (The direction is the 1pin of product is at the upper left when you hold reel on the left hand and you pull out the tape on the right hand)

Reel

1pin

Direction of feed

\* Order quantity needs to be multiple of the minimum quantity.

## Revision History

Date	Revision	Changes
31.Mar.2017	001	New Release

# Notice

## Precaution on using ROHM Products

- Our Products are designed and manufactured for application in ordinary electronic equipments (such as AV equipment, OA equipment, telecommunication equipment, home electronic appliances, amusement equipment, etc.). If you intend to use our Products in devices requiring extremely high reliability (such as medical equipment <sup>(Note 1)</sup>, transport equipment, traffic equipment, aircraft/spacecraft, nuclear power controllers, fuel controllers, car equipment including car accessories, safety devices, etc.) and whose malfunction or failure may cause loss of human life, bodily injury or serious damage to property ("Specific Applications"), please consult with the ROHM sales representative in advance. Unless otherwise agreed in writing by ROHM in advance, ROHM shall not be in any way responsible or liable for any damages, expenses or losses incurred by you or third parties arising from the use of any ROHM's Products for Specific Applications.

(Note1) Medical Equipment Classification of the Specific Applications

JAPAN	USA	EU	CHINA
CLASS III	CLASS III	CLASS II b	CLASS III
CLASS IV		CLASS III	

- ROHM designs and manufactures its Products subject to strict quality control system. However, semiconductor products can fail or malfunction at a certain rate. Please be sure to implement, at your own responsibilities, adequate safety measures including but not limited to fail-safe design against the physical injury, damage to any property, which a failure or malfunction of our Products may cause. The following are examples of safety measures:
  - Installation of protection circuits or other protective devices to improve system safety
  - Installation of redundant circuits to reduce the impact of single or multiple circuit failure
- Our Products are designed and manufactured for use under standard conditions and not under any special or extraordinary environments or conditions, as exemplified below. Accordingly, ROHM shall not be in any way responsible or liable for any damages, expenses or losses arising from the use of any ROHM's Products under any special or extraordinary environments or conditions. If you intend to use our Products under any special or extraordinary environments or conditions (as exemplified below), your independent verification and confirmation of product performance, reliability, etc. prior to use, must be necessary:
  - Use of our Products in any types of liquid, including water, oils, chemicals, and organic solvents
  - Use of our Products outdoors or in places where the Products are exposed to direct sunlight or dust
  - Use of our Products in places where the Products are exposed to sea wind or corrosive gases, including Cl<sub>2</sub>, H<sub>2</sub>S, NH<sub>3</sub>, SO<sub>2</sub>, and NO<sub>2</sub>
  - Use of our Products in places where the Products are exposed to static electricity or electromagnetic waves
  - Use of our Products in proximity to heat-producing components, plastic cords, or other flammable items
  - Sealing or coating our Products with resin or other coating materials
  - Use of our Products without cleaning residue of flux (even if you use no-clean type fluxes, cleaning residue of flux is recommended); or Washing our Products by using water or water-soluble cleaning agents for cleaning residue after soldering
  - Use of the Products in places subject to dew condensation
- The Products are not subject to radiation-proof design.
- Please verify and confirm characteristics of the final or mounted products in using the Products.
- In particular, if a transient load (a large amount of load applied in a short period of time, such as pulse. is applied, confirmation of performance characteristics after on-board mounting is strongly recommended. Avoid applying power exceeding normal rated power; exceeding the power rating under steady-state loading condition may negatively affect product performance and reliability.
- De-rate Power Dissipation depending on ambient temperature. When used in sealed area, confirm that it is the use in the range that does not exceed the maximum junction temperature.
- Confirm that operation temperature is within the specified range described in the product specification.
- ROHM shall not be in any way responsible or liable for failure induced under deviant condition from what is defined in this document.

## Precaution for Mounting / Circuit board design

- When a highly active halogenous (chlorine, bromine, etc.) flux is used, the residue of flux may negatively affect product performance and reliability.
- In principle, the reflow soldering method must be used on a surface-mount products, the flow soldering method must be used on a through hole mount products. If the flow soldering method is preferred on a surface-mount products, please consult with the ROHM representative in advance.

For details, please refer to ROHM Mounting specification

### Precautions Regarding Application Examples and External Circuits

1. If change is made to the constant of an external circuit, please allow a sufficient margin considering variations of the characteristics of the Products and external components, including transient characteristics, as well as static characteristics.
2. You agree that application notes, reference designs, and associated data and information contained in this document are presented only as guidance for Products use. Therefore, in case you use such information, you are solely responsible for it and you must exercise your own independent verification and judgment in the use of such information contained in this document. ROHM shall not be in any way responsible or liable for any damages, expenses or losses incurred by you or third parties arising from the use of such information.

### Precaution for Electrostatic

This Product is electrostatic sensitive product, which may be damaged due to electrostatic discharge. Please take proper caution in your manufacturing process and storage so that voltage exceeding the Products maximum rating will not be applied to Products. Please take special care under dry condition (e.g. Grounding of human body / equipment / solder iron, isolation from charged objects, setting of Ionizer, friction prevention and temperature / humidity control).

### Precaution for Storage / Transportation

1. Product performance and soldered connections may deteriorate if the Products are stored in the places where:
  - [a] the Products are exposed to sea winds or corrosive gases, including Cl<sub>2</sub>, H<sub>2</sub>S, NH<sub>3</sub>, SO<sub>2</sub>, and NO<sub>2</sub>
  - [b] the temperature or humidity exceeds those recommended by ROHM
  - [c] the Products are exposed to direct sunshine or condensation
  - [d] the Products are exposed to high Electrostatic
2. Even under ROHM recommended storage condition, solderability of products out of recommended storage time period may be degraded. It is strongly recommended to confirm solderability before using Products of which storage time is exceeding the recommended storage time period.
3. Store / transport cartons in the correct direction, which is indicated on a carton with a symbol. Otherwise bent leads may occur due to excessive stress applied when dropping of a carton.
4. Use Products within the specified time after opening a humidity barrier bag. Baking is required before using Products of which storage time is exceeding the recommended storage time period.

### Precaution for Product Label

A two-dimensional barcode printed on ROHM Products label is for ROHM's internal use only.

### Precaution for Disposition

When disposing Products please dispose them properly using an authorized industry waste company.

### Precaution for Foreign Exchange and Foreign Trade act

Since concerned goods might be fallen under listed items of export control prescribed by Foreign exchange and Foreign trade act, please consult with ROHM in case of export.

### Precaution Regarding Intellectual Property Rights

1. All information and data including but not limited to application example contained in this document is for reference only. ROHM does not warrant that foregoing information or data will not infringe any intellectual property rights or any other rights of any third party regarding such information or data.
2. ROHM shall not have any obligations where the claims, actions or demands arising from the combination of the Products with other articles such as components, circuits, systems or external equipment (including software).
3. No license, expressly or implied, is granted hereby under any intellectual property rights or other rights of ROHM or any third parties with respect to the Products or the information contained in this document. Provided, however, that ROHM will not assert its intellectual property rights or other rights against you or your customers to the extent necessary to manufacture or sell products containing the Products, subject to the terms and conditions herein.

### Other Precaution

1. This document may not be reprinted or reproduced, in whole or in part, without prior written consent of ROHM.
2. The Products may not be disassembled, converted, modified, reproduced or otherwise changed without prior written consent of ROHM.
3. In no event shall you use in any way whatsoever the Products and the related technical information contained in the Products or this document for any military purposes, including but not limited to, the development of mass-destruction weapons.
4. The proper names of companies or products described in this document are trademarks or registered trademarks of ROHM, its affiliated companies or third parties.

**General Precaution**

1. Before you use our Products, you are requested to carefully read this document and fully understand its contents. ROHM shall not be in any way responsible or liable for failure, malfunction or accident arising from the use of any ROHM's Products against warning, caution or note contained in this document.
2. All information contained in this document is current as of the issuing date and subject to change without any prior notice. Before purchasing or using ROHM's Products, please confirm the latest information with a ROHM sales representative.
3. The information contained in this document is provided on an "as is" basis and ROHM does not warrant that all information contained in this document is accurate and/or error-free. ROHM shall not be in any way responsible or liable for any damages, expenses or losses incurred by you or third parties resulting from inaccuracy or errors of or concerning such information.

# Mouser Electronics

Authorized Distributor

Click to View Pricing, Inventory, Delivery & Lifecycle Information:

[ROHM Semiconductor:](#)

[BU22210MUV-E2](#)