

EVALUATION BOARD MANUAL

EBSHCN Series

EVALUATION KIT MANUAL

EKSHCN Series

for EYSHCN series Bluetooth[®] low energy Module



Introduction

This evaluation board is applicable for Taiyo Yuden's **Bluetooth® low energy** module, EYSHCN Series.

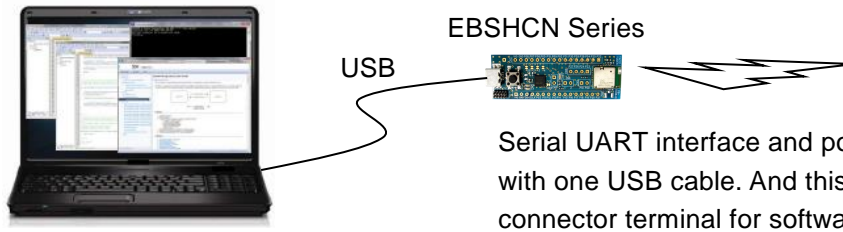

Mounted module

EYSHCN Series (9.6mm x 12.9mm x 2.0mm_MAX)



Nordic nRF52832 / ARM® Cortex™-M4F 32 bit processor
49-pin Land Grid Array / 30GPIOs / SWD

- Basic Module -

Taiyo Yuden writes SoftDevice to this product.

The user can develop unique application for the module.

Content

1	EBSHCN Series Evaluation Board (PCB name_TE8648-1)	1 pc
2	J-Link Lite (EKSHCN Series Only)	1 set



Evaluation board circuit schematic

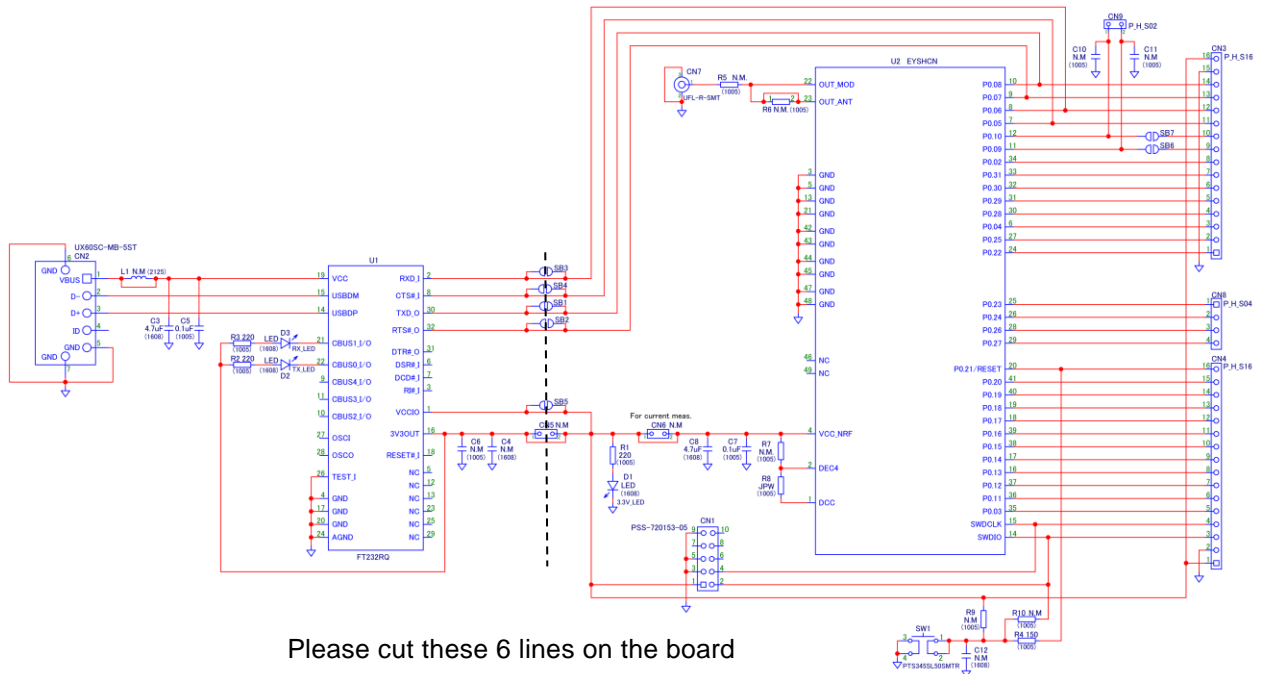

Please cut these 6 lines on the board if you want to separate U1 and U2.

Evaluation board layout

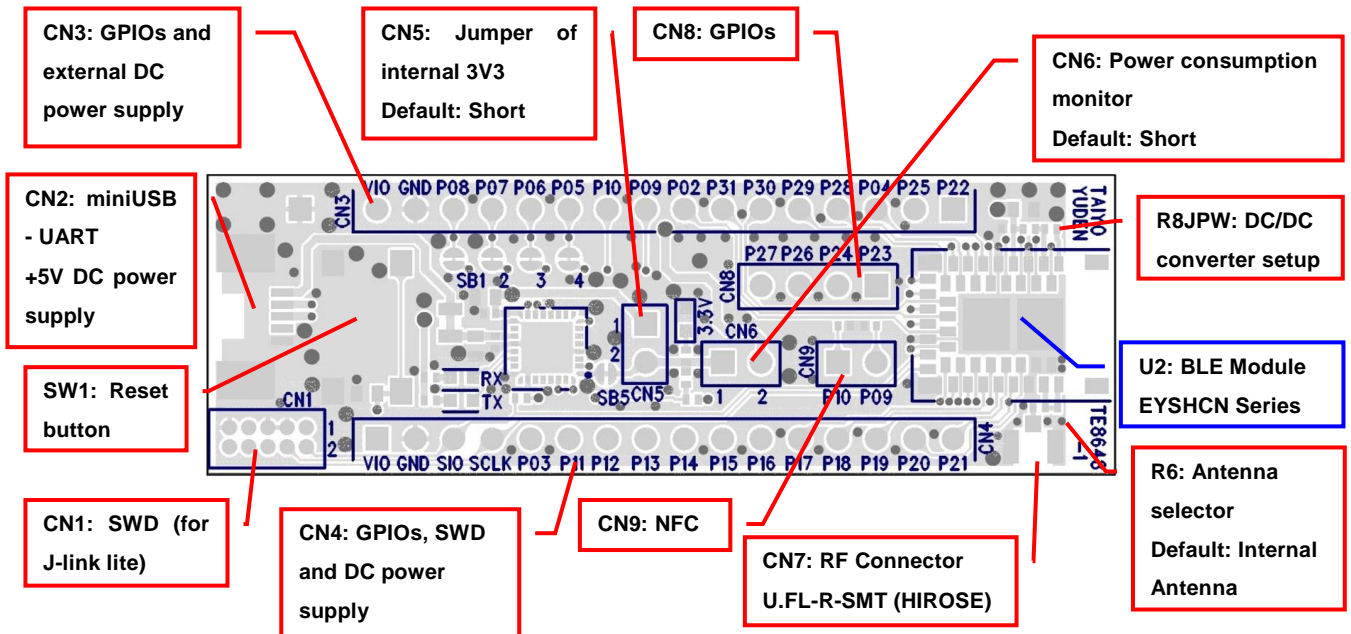

- 1) All pin headers are 2.54mm pitch. And distance between **CN3** and **CN4** is **15.24mm**.
- 2) **CN3,4,5,6,8, C4,6,10-12, L1, R5-7,9,10, SB1-7, TP1** are not mounted (N.M.).
- 3) **D1 (LED)**: 3.3V Indicator
- 4) **D2 (LED)**: UART TX Indicator
- 5) **D3 (LED)**: UART RX Indicator
- 6) **SW1 (Push button)**: Module Reset (active low)

Silkscreen Printing

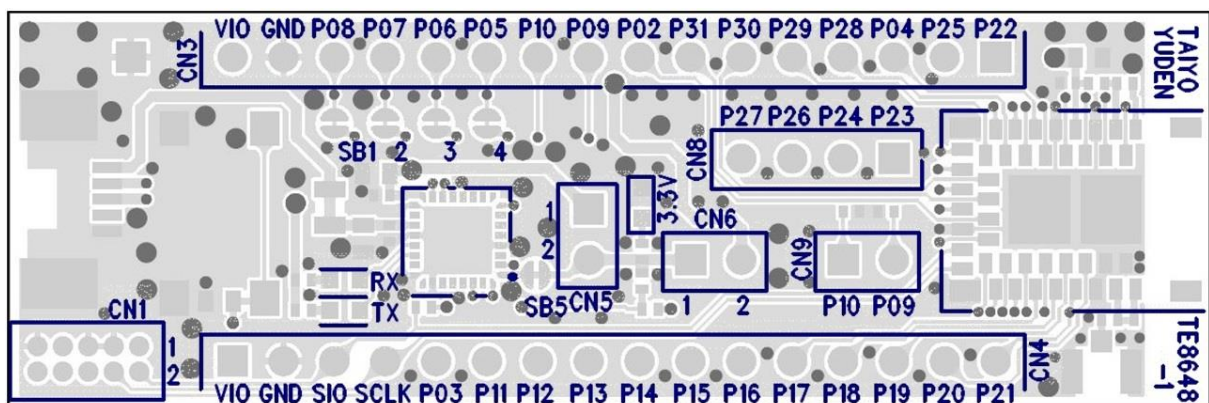

Pin Descriptions

Pin No.	CN3	CN4	CN8
1	P0.22	VIO	P0.23
2	P0.25	GND	P0.24
3	P0.04	SWDIO	P0.26
4	P0.28	SWDCLK	P0.27
5	P0.29	P0.03	
6	P0.30	P0.11	
7	P0.31	P0.12	
8	P0.02	P0.13	
9	NFC/P0.09	P0.14	
10	NFC/P0.10	P0.15	
11	P0.05	P0.16	
12	P0.06	P0.17	
13	P0.07	P0.18	
14	P0.08	P0.19	
15	GND	P0.20	
16	VIO	P0.21/RESET	

EBSHCN, EKSHCN

TAIYO YUDEN CO., LTD.

How to use

It is very easy just to tie this board to the PC with a USB cable. It is not necessary to change the setting of the board. The power supply of the module supplies by default 3.3V from 3V3OUT of FT232RQ.

For software development

Nordic-DK and Use case

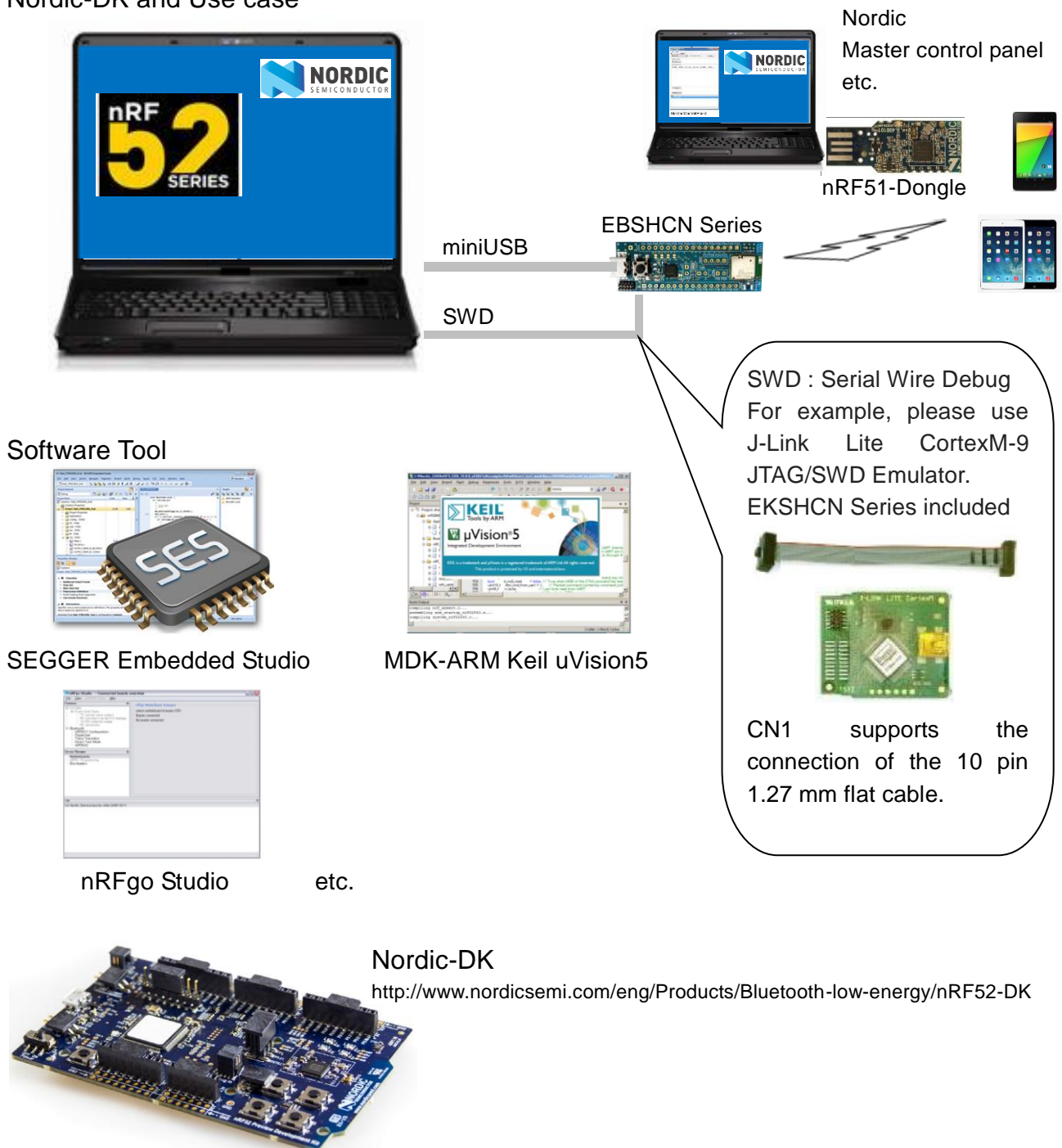

TAIYO YUDEN CO., LTD.

MEMO

1) Current measurement

To measure the current, please cut the shorting 1pin and 2 pin of CN6. And connect an ampere-meter between the pins of connector CN6 to monitor the current directly.

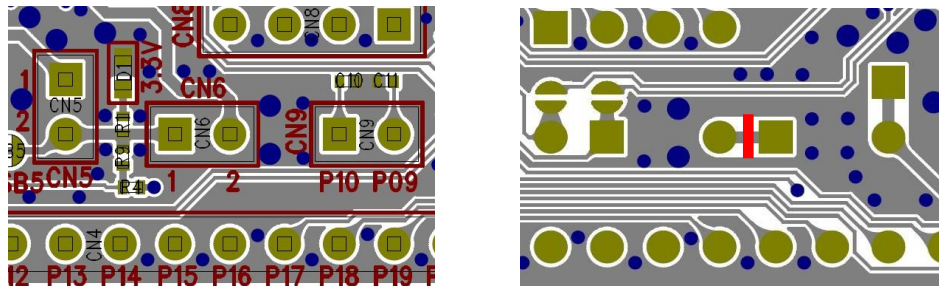

2) About the power supply of the module

When you use external power supply, please supply power from 15 and 16pin of CN3. On this configuration, please cut the short circuit 1pin and 2pin of CN5 in order to separate 3V3OUT of FT232RQ.

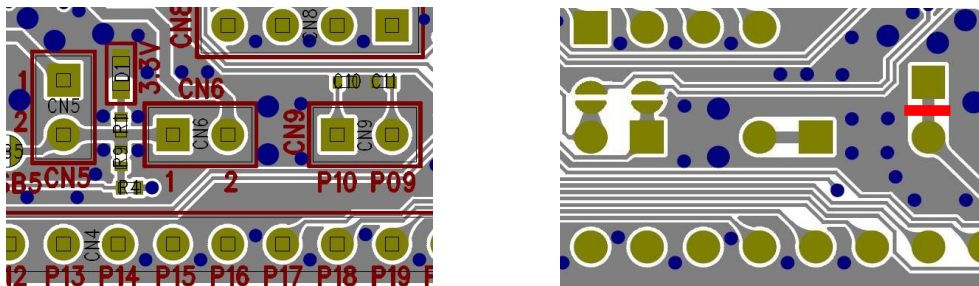

3) USB to serial UART interface

It needs to install driver of FT232RQ to use USB for UART interface. The drivers are available on FTDI website.

<http://www.ftdichip.com/Drivers/D2XX.htm>

In addition, by the application development, please assign GPIO as follows.

GPIO	UART
P0.05	RTS
P0.06	TX
P0.07	CTS
P0.08	RX

4) Size and Coordinate information

