

## Differential Clock Buffer/Driver

### Features

- Phase-locked loop clock distribution for Double Data Rate Synchronous DRAM applications
- 1:10 differential outputs
- External Feedback pins (FBINT, FBINC) are used to synchronize the outputs to the clock input
- SSCG: Spread Aware™ for EMI reduction
- 48-pin SSOP and TSSOP packages
- Conforms to JEDEC JC40 and JC42.5 DDR specifications

### Description

This PLL clock buffer is designed for 2.5 VDD and 2.5 AVDD operation and differential data input and output levels.

This device is a zero-delay buffer that distributes a differential clock input pair (CLKINT, CLKINC) to ten differential pair of clock outputs (YT[0:9], YC[0:9]) and one differential pair feedback clock output (FBOUTT, FBOUTC). The clock outputs are individually controlled by the serial inputs SCLK and SDATA.

The two-line serial bus can set each output clock pair (YT[0:9], YC[0:9]) to the Hi-Z state. When AVDD is grounded, the PLL is turned off and bypassed for test purposes.

The PLL in this device uses the input clocks (CLKINT, CLKINC) and the feedback clocks (FBINT, FBINC) to provide high-performance, low-skew, low-jitter output differential clocks.

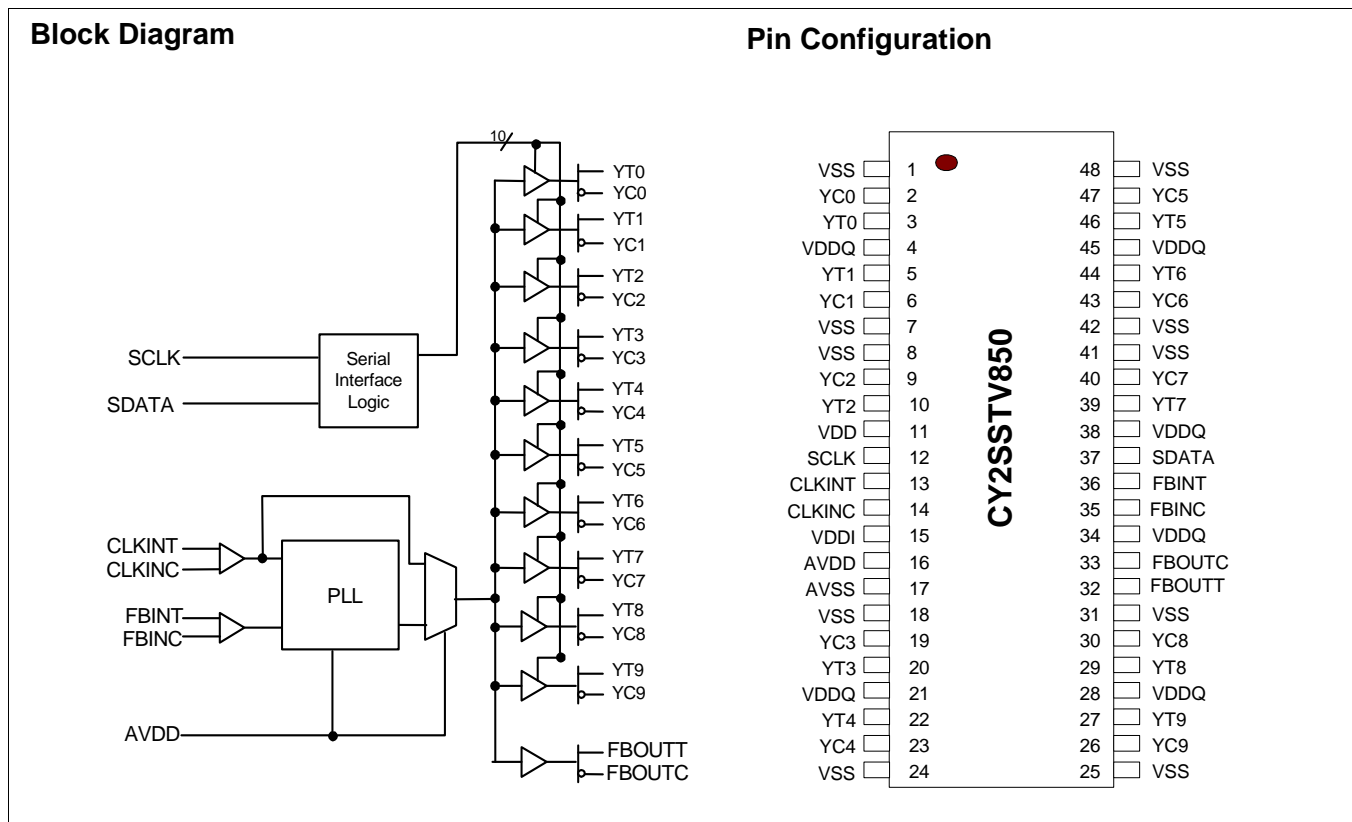

Pin Description<sup>[1, 2]</sup>

Pin	Name	I/O	Description	Electrical Characteristics
13	CLKINT	I	<b>Complementary Clock Input.</b>	LV Differential Input
14	CLKINC	I	<b>Complementary Clock Input.</b>	
35	FBINC	I	<b>Feedback Clock Input.</b> Connect to FBOUTC for accessing the PLL.	Differential Input
36	FBINT	I	<b>Feedback Clock Input.</b> Connect to FBOUTT for accessing the PLL.	
3, 5, 10, 20, 22 46, 44, 39, 29,27	YT(0:9)	O	<b>Clock Outputs</b>	Differential Outputs
2, 6, 9, 19, 23 47, 43, 40,30,26	YC(0:9)	O	<b>Clock Outputs</b>	
32	FBOUTT	O	<b>Feedback Clock Output.</b> Connect to FBINT for normal operation. A bypass delay capacitor at this output will control Input Reference/Output Clocks phase relationships.	Differential Outputs
33	FBOUTC	O	<b>Feedback Clock Output.</b> Connect to FBINC for normal operation. A bypass delay capacitor at this output will control Input Reference/Output Clocks phase relationships.	
12	SCLK	I, PU	<b>Serial Clock Input.</b> Clocks data at SDATA into the internal register.	Data Input for the two-line serial bus
37	SDATA	I/O, PU	<b>Serial Data Input.</b> Input data is clocked to the internal register to enable/disable individual outputs. This provides flexibility in power management.	Data Input and Output for the two-line serial bus
11	VDD		<b>2.5V power Supply for Logic</b>	2.5V Nominal
4, 21, 28, 34, 38, 45	VDDQ		<b>2.5V Power Supply for Output Clock Buffers</b>	2.5V Nominal
16	AVDD		<b>2.5V Power Supply for PLL</b>	2.5V Nominal
15	VDDI		<b>Power Supply for two-line serial Interface</b>	2.5V or 3.3V Nominal
1, 7, 8, 18, 24, 25, 31, 41, 42, 48	VSS		<b>Common Ground</b>	0.0V Ground
17	AVSS		<b>Analog Ground</b>	0.0V Analog Ground

Notes:

1. PU= internal pull-up
2. A bypass capacitor (0.1  $\mu$ F) should be placed as close as possible to each positive power pin (<0.2"). If these bypass capacitors are not close to the pins their high-frequency filtering characteristic will be cancelled by the lead inductance of the traces

**Function Table**

Inputs					Outputs				PLL
AVDD	CLKINT		CLKINC		YT(0:9) <sup>[3]</sup>	YC(0:9) <sup>[3]</sup>	FBOUTT	FBOUTC	
GND	L		H		L	H	L	H	BYPASSED/OFF
GND	H		L		H	L	H	L	BYPASSED/OFF
2.5V	L		H		L	H	L	H	On
2.5V	H		L		H	L	H	L	On
	Nom	Design	Nom	Design					
2.5V	<20 MHz	<30 MHz	<20 MHz	<30 MHz	Hi-Z	Hi-Z	Hi-Z	Hi-Z	Off

**Power Management**

The individual output enable/disable control of the CY2SSTV850 allows the user to implement unique power management schemes into the design. Outputs are three-stated when disabled through the two-line interface as individual bits are set low in Byte 0 and Byte 1 registers. The feedback output pair (FBOUTT, FBOUTC) cannot be disabled via two-line serial bus. The enabling and disabling of individual outputs is done in such a manner as to eliminate the possibility of partial “runt” clocks.

**Zero-delay Buffer**

When used as a zero-delay buffer the CY2SSTV850 will likely be in a nested clock tree application. For these applications the CY2SSTV850 offers a differential clock input pair as a PLL reference. The CY2SSTV850 then can lock onto the reference and translate with near zero delay to low-skew outputs. For normal operation, the external feedback input, FBINT, is connected to the feedback output, FBOUTT. By connecting the feedback output to the feedback input the propagation delay through the device is eliminated. The PLL works to align the output edge with the input reference edge thus producing a near zero delay. The reference frequency affects the static phase offset of the PLL and thus the relative delay between the inputs and outputs.

When AVDD is strapped low, the PLL is turned off and bypassed for test purposes.

**Serial Control Registers**

Following the acknowledge of the Address Byte, two additional bytes must be sent:

“Command Code” byte, and “Byte Count” byte.

**2 Line Serial Interface**

**2-Line Serial Interface Slave Address**

A7	A6	A5	A4	A3	A2	A1	R/W
1	1	0	1	0	0	1	0

Writing to the device is accomplished by sequentially sending the device address D2H, the dummy bytes (command code and the number of bytes), and the data bytes. This sequence is illustrated in the following tables.

**Note:**

- 3. Each output pair can be three-stated via the two-line serial interface.

**Byte0: Output Register (1 = Enable, 0 = Disable)**

Bit	@Pup	Pin#	Description
7	1	3, 2	YT0, YC0
6	1	5, 6	YT1, YC1
5	1	10, 9	YT2, YC2
4	1	20, 19	YT3, YC3
3	1	22, 23	YT4, YC4
2	1	46, 47	YT5, YC5
1	1	44, 43	YT6, YC6
0	1	39, 40	YT7, YC7

**Byte1: Output Register (1 = Enable, 0 = Disable)**

Bit	@Pup	Pin#	Description
7	1	29, 30	YT8, YC8
6	1	27, 26	YT9, YC9
5	0		Reserved
4	0		Reserved
3	0		Reserved
2	0		Reserved
1	0		Reserved
0	0		Reserved

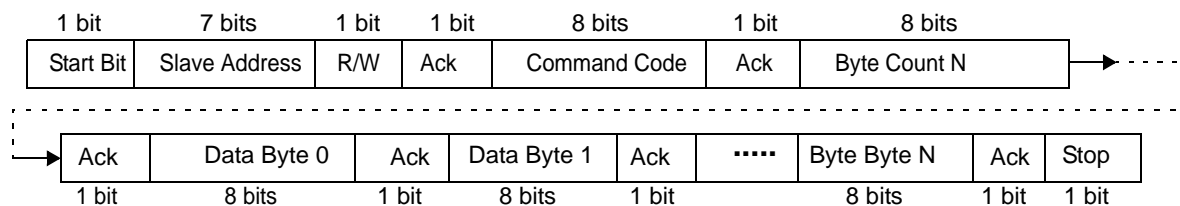

**Table 1. Timing Requirements for the 2-line Serial Interface over Recommended Ranges of Operating Free-air Temperature and VDDI from 3.3V to 3.5V**

Parameter	Description	Min.	Max.	Unit
$f_{SCLK}$	SCLK frequency		100	kHz
$t_{BUS}$	Bus free time	4.7		$\mu$ s
$t_{SU}(START)$	START set-up time	4.7		$\mu$ s
$t_{H}(START)$	START hold time	4.0		$\mu$ s
$t_{W}(SCLL)$	SCLK low pulse duration	4.7		$\mu$ s
$t_{W}(SCLH)$	SCLK high pulse duration	4.0		$\mu$ s
$t_{R}(SDATA)$	SDATA input rise time		1000	ns
$t_{F}(SDATA)$	SDATA input fall time		300	ns
$t_{SU}(SDATA)$	SDATA set-up time	250		ns
$t_{H}(SDATA)$	SDATA hold time	0		ns
$t_{SU}(STOP)$	STOP set-up time	4		$\mu$ s

**Maximum Ratings<sup>[4]</sup>**

Input Voltage Relative to  $V_{SS}$ : .....  $V_{SS} - 0.3V$   
 Input Voltage Relative to  $V_{DDQ}$  or  $AV_{DD}$ : .....  $V_{DD} + 0.3V$   
 Storage Temperature: .....  $-65^{\circ}C$  to  $+150^{\circ}C$   
 Operating Temperature: .....  $0^{\circ}C$  to  $+70^{\circ}C$   
 Maximum Power Supply: .....  $3.5V$

This device contains circuitry to protect the inputs against damage due to high static voltages or electric fields; however, precautions should be taken to avoid application of any voltage higher than the maximum rated voltages to this circuit. For proper operation,  $V_{in}$  and  $V_{out}$  should be constrained to the range:

$$V_{SS} < (V_{in} \text{ or } V_{out}) < V_{DD}$$

Unused inputs must always be tied to an appropriate logic voltage level (either  $V_{SS}$  or  $V_{DD}$ ).

**DC Parameters<sup>[5]</sup>** ( $AV_{DD} = V_{DDQ} = 2.5V \pm 5\%$ ,  $V_{DDI} = 3.3V \pm 5\%$ ,  $T_A = 0^{\circ}C$  to  $+70^{\circ}C$ )

Parameter	Description	Conditions	Min.	Typ.	Max.	Unit
$V_{IL}$	Input Low Voltage	SDATA, SCLK			1.0	V
$V_{IH}$	Input High Voltage		2.2			V
$V_{ID}$	Differential Input Voltage <sup>[6]</sup>	CLKINT, FBINT	0.35		$V_{DDQ} + 0.6$	V
$V_{IX}$	Differential Input Crossing Voltage <sup>[7]</sup>	CLKTIN, FBINT	$(V_{DDQ}/2) - 0.2$	$V_{DDQ}/2$	$(V_{DDQ}/2) + 0.2$	V
$I_{IN}$	Input Current	$V_{IN} = 0V$ or $V_{IN} = V_{DDQ}$ , CLKINT, FBINT	-10		10	$\mu A$
$I_{OL}$	Output Low Current	$V_{DDQ} = 2.375V$ , $V_{OUT} = 1.2V$	26	35		mA
$I_{OH}$	Output High Current	$V_{DDQ} = 2.375V$ , $V_{OUT} = 1V$	-18	-32		mA
$V_{OL}$	Output Low Voltage	$V_{DDQ} = 2.375V$ , $I_{OL} = 12$ mA			0.6	V
$V_{OH}$	Output High Voltage	$V_{DDQ} = 2.375V$ , $I_{OH} = -12$ mA	1.7			V
$V_{OUT}$	Output Voltage Swing <sup>[8]</sup>		1.1		$V_{DDQ} - 0.4$	V
$V_{OC}$	Output Crossing Voltage <sup>[9]</sup>		$(V_{DDQ}/2) - 0.2$	$V_{DDQ}/2$	$(V_{DDQ}/2) + 0.2$	V
$I_{OZ}$	High-Impedance Output Current	$V_O = GND$ or $V_O = V_{DDQ}$	-10		10	$\mu A$
$I_{DDQ}$	Dynamic Supply Current <sup>[10]</sup>	All $V_{DDQ}$ and $V_{DDI}$ , $F_O = 170$ MHz		235	300	mA
$I_{DD}$	PLL Supply Current	AVDD only		9	12	mA
$C_{in}$	Input Pin Capacitance		2.5	3	3.5	pF

**Notes:**

4. **Multiple Supplies:** The Voltage on any input or I/O pin cannot exceed the power pin during power-up. Power supply sequencing is NOT required.
5. Unused inputs must be held HIGH or LOW to prevent them from floating.
6. Differential input signal voltage specifies the differential voltage  $|V_{TR} - V_{CP}|$  required for switching, where VTR is the true input level and VCP is the complementary input level.
7. Differential cross-point input voltage is expected to track  $V_{DDQ}$  and is the voltage at which the differential signals must be crossing.
8. For load conditions see Figure 6.
9. The value of  $V_{OC}$  is expected to be  $|V_{TR} + V_{CP}|/2$ . In case of each clock directly terminated by a 120 $\Omega$  resistor. See Figure 6.
10. All outputs switching loaded with 16 pF in 60 $\Omega$  environment. See Figure 6.

**AC Parameters**<sup>[11, 12]</sup> ( $V_{DD} = V_{DDQ} = 2.5V \pm 5\%$ ,  $V_{DDI} = 3.3V \pm 5\%$ ,  $T_A = 0^\circ C$  to  $+70^\circ C$ )

Parameter	Description	Conditions	Min.	Typ.	Max.	Unit
$f_{CLK}$	Operating Clock Frequency	$A_{VDD}, V_{DD} = 2.5V \pm 0.2V$	60		170	MHz
$t_{DC}$	Input Clock Duty Cycle <sup>[13]</sup>		40		60	%
$t_{lock}$	Maximum PLL lock Time				100	$\mu s$
$t_R/t_F$	Output Clocks Slew Rate	20% to 80% of VOD	1		2	V/ns
$t_{pZL}, t_{pZH}$	Output Enable Time <sup>[14]</sup> (all outputs)			3		ns
$t_{pLZ}, t_{pHZ}$	Output Disable Time <sup>[14]</sup> (all outputs)			3		ns
$t_{CCJ}$	Cycle to Cycle Jitter	$f > 66$ MHz	-100		100	ps
$t_{jit(h-per)}$	Half-period jitter <sup>[15]</sup>	$f > 66$ MHz	-100		100	ps
$t_{PLH}$	Low-to-High Propagation Delay, CLKINT to YT[0:9]		1.5	3.5	6	ns
$t_{PHL}$	High-to-Low Propagation Delay, CLKINT to YT[0:9]		1.5	3.5	6	ns
$t_{SK(0)}$	Any Output to Any Output Skew <sup>[16]</sup>				100	ps
$t_{PHASE}$	Phase Error <sup>[16]</sup>		-150		150	ps
$t_{JITT(PHASE)}$	Phase Error Jitter	$f > 66$ MHz	-50		50	ps
$t_{d(0)}$	Dynamic Phase Offset	CLKIN pins to FBIN pins at the DUT <sup>[17]</sup>	30		140	ps

**Note:**

- 11. Parameters are guaranteed by design and characterization. Not 100% tested in production.
- 12. PLL is capable of meeting the specified parameters while supporting SSC synthesizers with modulation frequency between 30 kHz and 33.3 kHz with a down spread of -0.5%.
- 13. While the pulse skew is almost constant over frequency, the duty cycle error increases at higher frequencies. This is due to the formula: duty cycle =  $t_{WH}/t_C$ , where the cycle time ( $t_C$ ) decreases as the frequency goes up.
- 14. Refers to transition of non-inverting output.
- 15. Period Jitter and Half-Period Jitter specifications are separate specifications that must be met independently of each other.
- 16. All differential input and output terminals are terminated with  $120\Omega/16$  pF as shown in *Figure 6*.
- 17. DUT refers to Device Under Test.

**Differential Parameter Measurement Information**

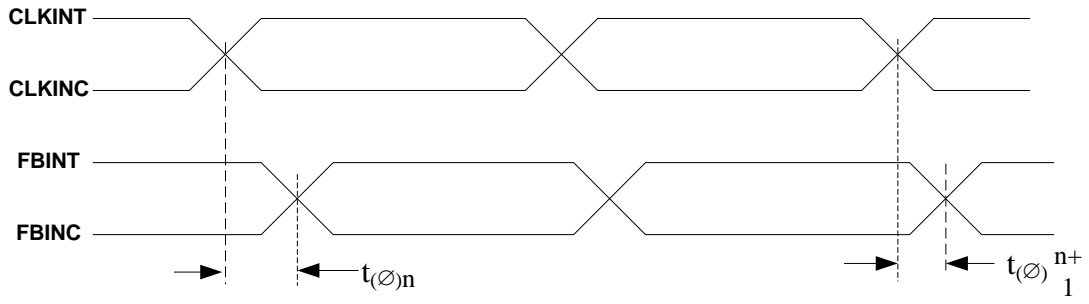

$$t(\phi)_n = \frac{\sum_{1}^{n=N} t(\phi)_n}{N} \quad N(\text{is large number of samples})$$

**Figure 1. Static Phase Offset**

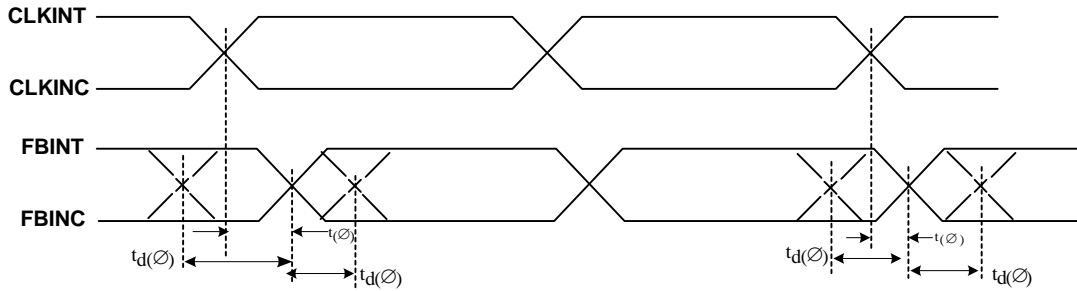

**Figure 2. Dynamic Phase Offset**

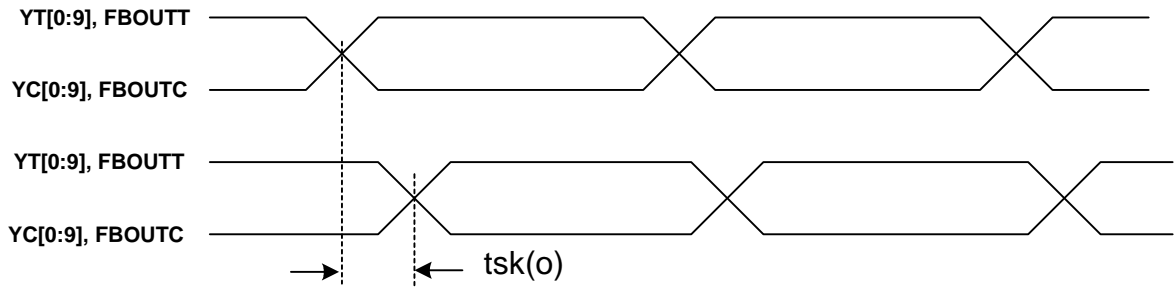

**Figure 3. Output Skew**

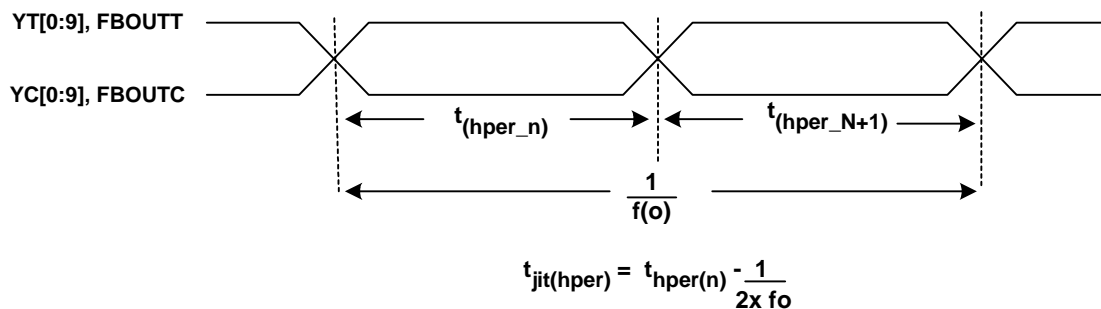

Figure 4. Half-Period Jitter

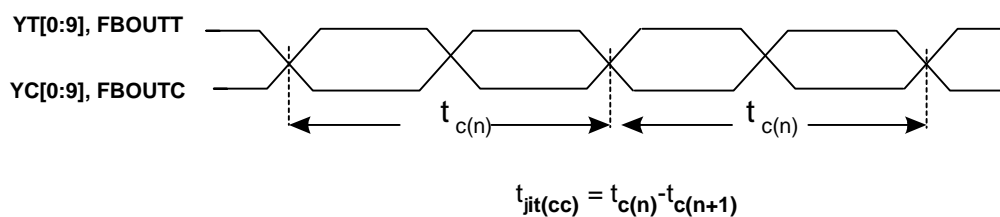

Figure 5. Cycle-to-Cycle Jitter

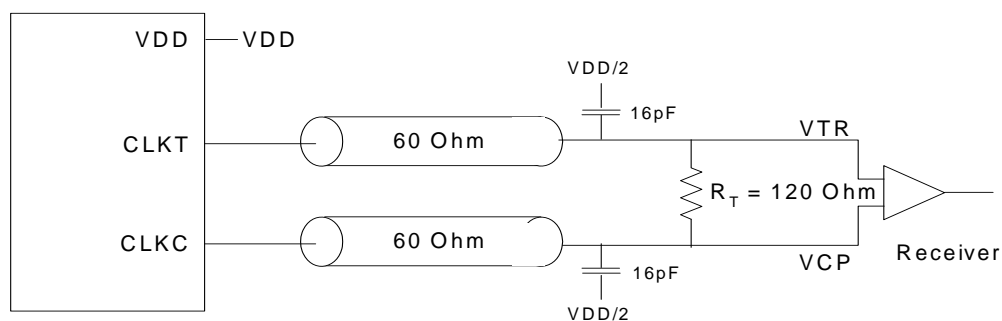

Figure 6. Differential Signal Using Direct Termination Resistor

### Ordering Information

Part Number	Package Type	Product Flow
CY2SSTV850OC	48-pin SSOP	Commercial, 0° to 70°C
CY2SSTV850OCT	48-pin SSOP - Tape and Reel	Commercial, 0° to 70°C
CY2SSTV850ZC	48-pin TSSOP	Commercial, 0° to 70°C
CY2SSTV850ZCT	48-pin TSSOP - Tape and Reel	Commercial, 0° to 70°C



**Package Drawing and Dimensions**

**48-Lead Shrunk Small Outline**

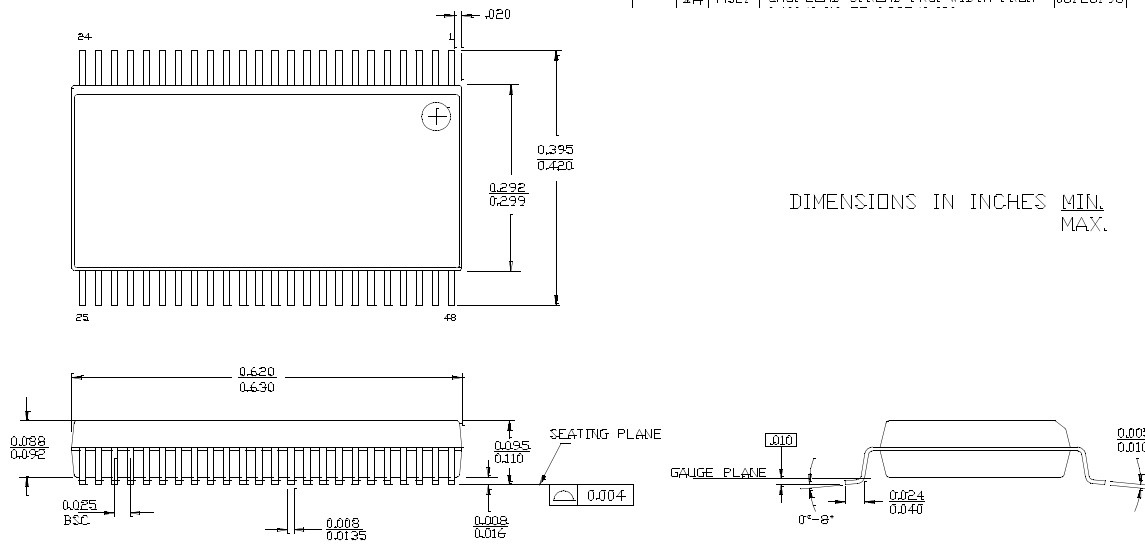

**48-Lead Thin Shrunk Small Outline Package, Type II (6 mm x 12 mm) Z48**

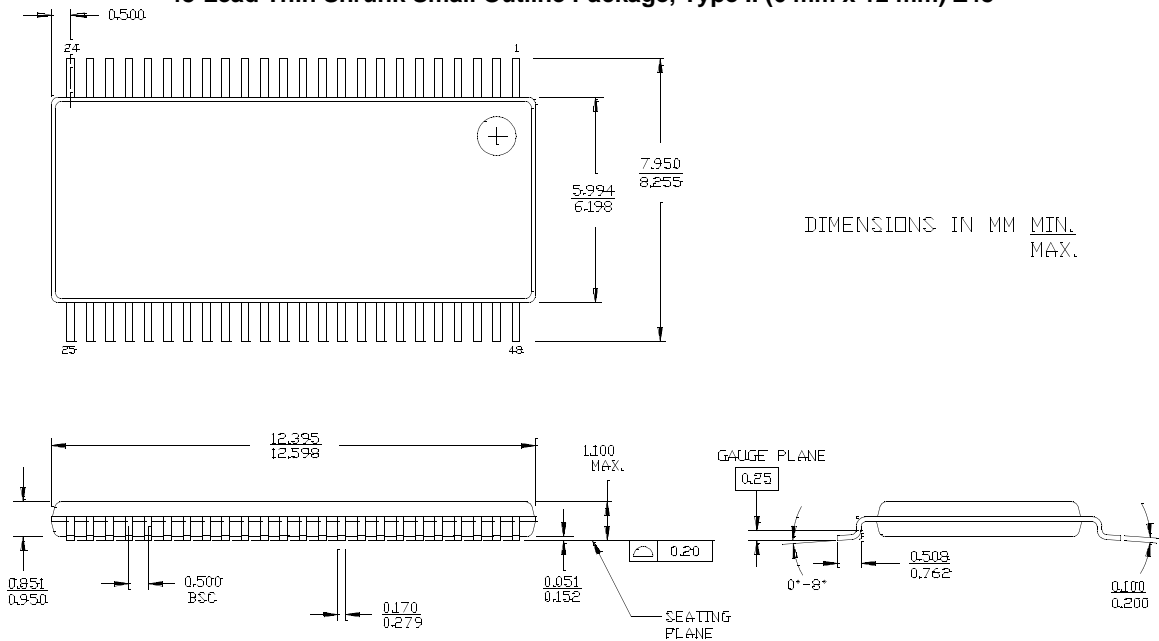

The information in this document is believed to be accurate in all respects at the time of publication but is subject to change without notice. Silicon Laboratories assumes no responsibility for errors and omissions, and disclaims responsibility for any consequences resulting from the use of information included herein. Additionally, Silicon Laboratories assumes no responsibility for the functioning of undescribed features or parameters. Silicon Laboratories reserves the right to make changes without further notice. Silicon Laboratories makes no warranty, representation or guarantee regarding the suitability of its products for any particular purpose, nor does Silicon Laboratories assume any liability arising out of the application or use of any product or circuit, and specifically disclaims any and all liability, including without limitation consequential or incidental damages. Silicon Laboratories products are not designed, intended, or authorized for use in applications intended to support or sustain life, or for any other application in which the failure of the Silicon Laboratories product could create a situation where personal injury or death may occur. Should Buyer purchase or use Silicon Laboratories products for any such unintended or unauthorized application, Buyer shall indemnify and hold Silicon Laboratories harmless against all claims and damages.