

General Description

The 8SLVP2106 is a high-performance differential dual 1:6 LVPECL fanout buffer. The device is designed for the fanout of high-frequency, very low additive phase-noise clock and data signals. The 8SLVP2106 is characterized to operate from a 3.3V or 2.5V power supply. Guaranteed output-to-output and part-to-part skew characteristics make the 8SLVP2106 ideal for those clock distribution applications demanding well-defined performance and repeatability. Two independent buffers with six low skew outputs each are available. The integrated bias voltage references enable easy interfacing of single-ended signals to the device inputs. The device is optimized for low power consumption and low additive phase noise.

Block Diagram

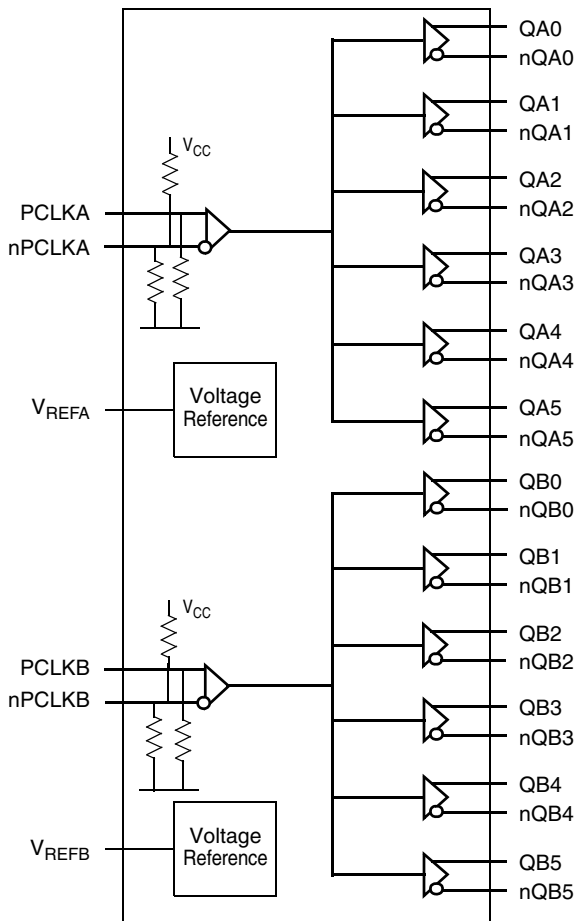

Features

- Two 1:6, low skew, low additive jitter LVPECL fanout buffers
- Two differential clock inputs
- Differential PCLKA, nPCLKA and PCLKB, nPCLKB pairs can accept the following differential input levels: LVDS, LVPECL, CML
- Differential PCLKA, nPCLKA and PCLKB, nPCLKB pairs can also accept single-ended LVCMOS levels. See Applications section *Wiring the Differential Input Levels to Accept Single-ended Levels* (Figure 1A and Figure 1B).
- Maximum input clock frequency: 2GHz
- Output bank skew: 15ps (typical)
- Propagation delay: 340ps (maximum)
- Low additive phase jitter, RMS: 54fs (maximum)
 $f_{REF} = 156.25\text{MHz}$, $V_{PP} = 1\text{V}$, 12kHz - 20MHz: $V_{CC} = 3.3\text{V}$
- Full 3.3V and 2.5V supply voltage modes
- Maximum device current consumption (I_{EE}): 114mA
- Available in Lead-free (RoHS 6), 40-Lead VFQFN package
- -40°C to 85°C ambient operating temperature
- Supports case temperature $\leq 105^\circ\text{C}$ operations

Pin Assignment

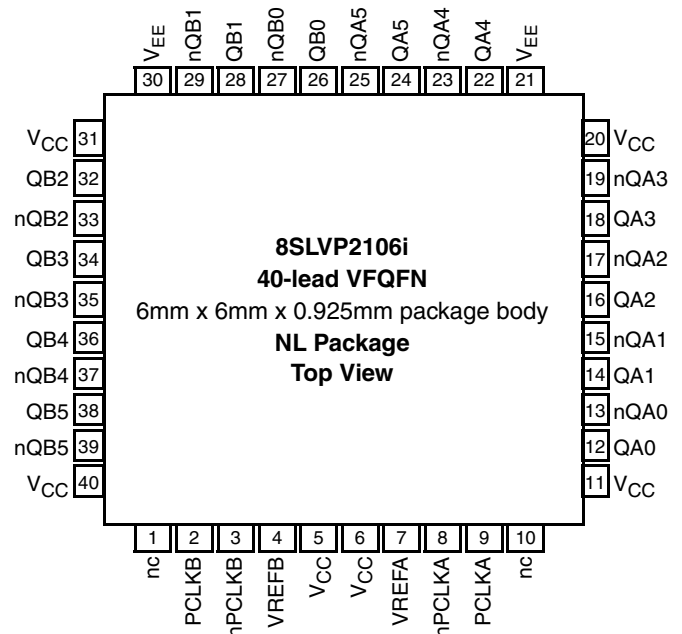

Pin Descriptions and Characteristics

Table 1. Pin Descriptions

Number	Name	Type		Description
1, 10	nc	Unused		Do not connect.
2	PCLKB	Input	Pulldown	Non-inverting LVPECL differential clock/data input.
3	nPCLKB	Input	Pulldown/ Pullup	Inverting LVPECL differential clock input.
4	V _{REFB}	Output		Bias voltage reference for the PCLKB, nPCLKB input pair.
5, 6, 11, 20, 31, 40	V _{CC}	Power		Power supply pins.
7	V _{REFA}	Output		Bias voltage reference for the PCLKA, nPCLKA input pair.
8	nPCLKA	Input	Pulldown/ Pullup	Inverting LVPECL differential clock input.
9	PCLKA	Input	Pulldown	Non-inverting LVPECL differential clock/data input.
12, 13	QA0, nQA0	Output		Differential output pair A0. LVPECL interface levels.
14, 15	QA1, nQA1	Output		Differential output pair A1. LVPECL interface levels.
16, 17	QA2, nQA2	Output		Differential output pair A2. LVPECL interface levels.
18, 19	QA3, nQA3	Output		Differential output pair A3. LVPECL interface levels.
21, 30	V _{EE}	Power		Negative supply pins.
22, 23	QA4, nQA4	Output		Differential output pair A4. LVPECL interface levels.
24, 25	QA5, nQA5	Output		Differential output pair A5. LVPECL interface levels.
26, 27	QB0, nQB0	Output		Differential output pair B0. LVPECL interface levels.
28, 29	QB1, nQB1	Output		Differential output pair B1. LVPECL interface levels.
32, 33	QB2, nQB2	Output		Differential output pair B2. LVPECL interface levels.
34, 35	QB3, nQB3	Output		Differential output pair B3. LVPECL interface levels.
36, 37	QB4, nQB4	Output		Differential output pair B4. LVPECL interface levels.
38, 39	QB5, nQB5	Output		Differential output pair B5. LVPECL interface levels.

NOTE: *Pulldown* and *Pullup* refer to internal input resistors. See Table 2, *Pin Characteristics*, for typical values.

Table 2. Pin Characteristics

Symbol	Parameter	Test Conditions	Minimum	Typical	Maximum	Units
C _{IN}	Input Capacitance			2		pF
R _{PULLDOWN}	Input Pulldown Resistor			51		kΩ
R _{PULLUP}	Input Pullup Resistor			51		kΩ

Absolute Maximum Ratings

NOTE: Stresses beyond those listed under *Absolute Maximum Ratings* may cause permanent damage to the device. These ratings are stress specifications only. Functional operation of the product at these conditions or any conditions beyond those listed in the *DC Characteristics* or *AC Characteristics* is not implied. Exposure to absolute maximum rating conditions for extended periods may affect product reliability.

Item	Rating
Supply Voltage, V_{CC}	4.6V
Inputs, V_I	-0.5V to $V_{CC} + 0.5V$
Outputs, I_O (LVPECL) Continuous Current Surge Current	50mA 100mA
Input Sink/Source, I_{REF}	$\pm 2mA$
Maximum Junction Temperature, $T_{J,MAX}$	125 °C
Storage Temperature, T_{STG}	-65°C to 150°C
ESD - Human Body Model (NOTE 1)	2000V
ESD - Charged Device Model (NOTE 1)	1500V

NOTE 1: According to JEDEC/JESD 22-A114/22-C101.

DC Electrical Characteristics

Table 3A. Power Supply DC Characteristics, $V_{CC} = 3.3V \pm 5\%$, $V_{EE} = 0V$, $T_A = -40^\circ C$ to $85^\circ C$

Symbol	Parameter	Test Conditions	Minimum	Typical	Maximum	Units
V_{CC}	Power Supply Voltage		3.135	3.3V	3.465	V
I_{EE}	Power Supply Current			94	114	mA
I_{CC}	Power Supply Current	QA[0:5] and QB[0:5] terminated 50Ω to $V_{CC} - 2V$		503	569	mA

Table 3B. Power Supply DC Characteristics, $V_{CC} = 2.5V \pm 5\%$, $V_{EE} = 0V$, $T_A = -40^\circ C$ to $85^\circ C$

Symbol	Parameter	Test Conditions	Minimum	Typical	Maximum	Units
V_{CC}	Power Supply Voltage		2.375	2.5V	2.625	V
I_{EE}	Power Supply Current			89	103	mA
I_{CC}	Power Supply Current	QA[0:5] and QB[0:5] terminated 50Ω to $V_{CC} - 2V$		502	569	mA

Table 3C. LVPECL DC Characteristics, $V_{CC} = 3.3V \pm 5\%$, $V_{EE} = 0V$, $T_A = -40^{\circ}C$ to $85^{\circ}C$

Symbol	Parameter	Test Conditions	Minimum	Typical	Maximum	Units
I_{IH}	Input High Current PCLKA, nPCLKA PCLKB, nPCLKB	$V_{CC} = V_{IN} = 3.465V$			150	μA
I_{IL}	Input Low Current PCLKA, PCLKB nPCLKA, nPCLKB	$V_{CC} = 3.465V, V_{IN} = 0V$	-10			μA
		$V_{CC} = 3.465V, V_{IN} = 0V$	-150			μA
V_{REFx}	Reference Voltage for Input Bias	$I_{REF} = 2mA$	$V_{CC} - 1.82$	$V_{CC} - 1.48$	$V_{CC} - 1.27$	V
V_{OH}	Output High Voltage; NOTE 1		$V_{CC} - 1.05$	$V_{CC} - 0.89$	$V_{CC} - 0.72$	V
V_{OL}	Output Low Voltage; NOTE 1		$V_{CC} - 1.50$	$V_{CC} - 1.38$	$V_{CC} - 1.26$	V

NOTE: V_{REFx} denotes V_{REFA} and V_{REFB} .NOTE 1: Outputs terminated with 50Ω to $V_{CC} - 2V$.**Table 3D. LVPECL DC Characteristics, $V_{CC} = 2.5V \pm 5\%$, $V_{EE} = 0V$, $T_A = -40^{\circ}C$ to $85^{\circ}C$**

Symbol	Parameter	Test Conditions	Minimum	Typical	Maximum	Units
I_{IH}	Input High Current PCLKA, nPCLKA PCLKB, nPCLKB	$V_{CC} = V_{IN} = 2.625V$			150	μA
I_{IL}	Input Low Current PCLKA, PCLKB nPCLKA, nPCLKB	$V_{CC} = 2.625V, V_{IN} = 0V$	-10			μA
		$V_{CC} = 2.625V, V_{IN} = 0V$	-150			μA
V_{REFx}	Reference Voltage for Input Bias; NOTE 2	$I_{REF} = 2mA$	$V_{CC} - 1.81$	$V_{CC} - 1.47$	$V_{CC} - 1.27$	V
V_{OH}	Output High Voltage; NOTE 1		$V_{CC} - 1.05$	$V_{CC} - 0.89$	$V_{CC} - 0.73$	V
V_{OL}	Output Low Voltage; NOTE 1		$V_{CC} - 1.48$	$V_{CC} - 1.36$	$V_{CC} - 1.23$	V

NOTE: V_{REFx} denotes V_{REFA} and V_{REFB} .NOTE 1: Outputs terminated with 50Ω to $V_{CC} - 2V$.NOTE 2: For $V_{CC} < 3V$, the use of an alternate bias voltage source is recommended.

AC Electrical Characteristics

Table 4A. AC Electrical Characteristics, $V_{CC} = 3.3V \pm 5\%$ or $2.5V \pm 5\%$, $V_{EE} = 0V$, $T_A = -40^\circ C$ to $85^\circ C$

Symbol	Parameter	Test Conditions	Minimum	Typical	Maximum	Units
f_{REF}	Input Frequency	PCLKA, nPCLKA and PCLKB, nPCLKB			2	GHz
$\Delta V/\Delta t$	Input Edge Rate	PCLKA, nPCLKA and PCLKB, nPCLKB	1.5			V/ns
t_{PD}	Propagation Delay; NOTE 1	PCLKA, nPCLKA to any QAx, nQAx or PCLKB, nPCLKB to any QBx, nQBx for $V_{PP} = 0.1V$ or $0.3V$	130	235	340	ps
$t_{sk(o)}$	Output Skew; NOTE 2, 3			26	60	ps
$t_{sk(b)}$	Output Bank Skew; NOTE 3, 4			15	42	ps
$t_{sk(p)}$	Pulse Skew	$f_{REF} = 100MHz$		6	26	ps
$t_{sk(pp)}$	Part-to-Part Skew; NOTE 3, 5			66	144	ps
$t_{JIT, SP}$	Spurious Suppression, Coupling from QA5 to QB0	$f_{QB0} = 500MHz$, $V_{PP(PCLKB)} = 0.15V$, $V_{CMR(PCLKB)} = 1V$; $f_{QA5} = 62.5MHz$, $V_{PP(PCLKA)} = 1V$, $V_{CMR(PCLKA)} = 1V$		-52		dB
		$f_{QB0} = 500MHz$, $V_{PP(PCLKB)} = 0.15V$, $V_{CMR(PCLKB)} = 1V$; $f_{QA5} = 15.625MHz$, $V_{PP(PCLKA)} = 1V$, $V_{CMR(PCLKA)} = 1V$		-63		dB
t_R / t_F	Output Rise/ Fall Time; NOTE 6	20% to 80%	60	100	170	ps
V_{PP}	Differential Input Voltage; NOTE 7, 8	$f_{REF} < 1.5GHz$	0.1		1.5	V
		$f_{REF} \geq 1.5GHz$	0.2		1.5	V
V_{CMR}	Common Mode Input Voltage; NOTE 7, 8, 9		1.0		$V_{CC} - 0.3$	V
$V_{O(pp)}$	Output Voltage Swing, Peak-to-Peak	$f_{REF} \leq 2GHz$, $V_{CC} = 2.5V \pm 5\%$	0.31	0.46	0.62	V
		$f_{REF} \leq 2GHz$, $V_{CC} = 3.3V \pm 5\%$	0.33	0.49	0.66	V
V_{DIFF_OUT}	Differential Output Voltage Swing, Peak-to-Peak	$f_{REF} \leq 2GHz$, $V_{CC} = 2.5V \pm 5\%$	0.62	0.92	1.24	V
		$f_{REF} \leq 2GHz$, $V_{CC} = 3.3V \pm 5\%$	0.66	0.98	1.32	V

NOTE: Electrical parameters are guaranteed over the specified ambient operating temperature range, which is established when the device is mounted in a test socket with maintained transverse airflow greater than 500 lpm. The device will meet specifications after thermal equilibrium has been reached under these conditions.

NOTE 1: Measured from the differential input crosspoint to the differential output crosspoint.

NOTE 2: Defined as skew between outputs at the same supply voltage and with equal load conditions. Measured at the differential crosspoints.

NOTE 3: This parameter is defined in accordance with JEDEC Standard 65.

NOTE 4: Defined as skew within a bank of outputs at the same supply voltage and with equal load conditions. Measured at the differential crosspoints.

NOTE 5: Defined as skew between outputs on different devices operating at the same supply voltage, same frequency, same temperature and with equal load conditions. Using the same type of inputs on each device, the outputs are measured at the differential crosspoints.

NOTE 6: Characterized with input signal meeting the input edge rate minimum specification.

NOTE 7: For single-ended LVCMOS input applications, please refer to the Applications Information, *Wiring the Differential Input to Accept Single-ended Levels*, Figures 1A and 1B.

NOTE 8: V_{IL} should not be less than $-0.3V$. V_{IH} should not be higher than V_{CC} .

NOTE 9: Common mode input voltage is defined at the crosspoint.

Table 4B. Buffer Additive Phase Jitter, t_{JIT} , $V_{CC} = 3.3V \pm 5\%$, $V_{EE} = 0V$, $T_A = -40^\circ C$ to $85^\circ C$

Symbol	Parameter	Test Conditions	Minimum	Typical	Maximum	Units
t_{JIT}	Buffer Additive Phase Jitter, RMS; refer to Additive Phase Jitter Section	$f_{REF} = 122.88\text{MHz}$ Square Wave, $V_{PP} = 1V$, Integration Range: 1kHz - 40MHz		98	113	fs
		$f_{REF} = 122.88\text{MHz}$ Square Wave, $V_{PP} = 1V$, Integration Range: 10kHz - 20MHz		61	81	fs
		$f_{REF} = 122.88\text{MHz}$ Square Wave, $V_{PP} = 1V$, Integration Range: 12kHz - 20MHz		61	81	fs
		$f_{REF} = 156.25\text{MHz}$ Square Wave, $V_{PP} = 1V$, Integration Range: 1kHz - 40MHz		63	74	fs
		$f_{REF} = 156.25\text{MHz}$ Square Wave, $V_{PP} = 1V$, Integration Range: 10kHz - 20MHz		46	55	fs
		$f_{REF} = 156.25\text{MHz}$ Square Wave, $V_{PP} = 1V$, Integration Range: 12kHz - 20MHz		46	54	fs
		$f_{REF} = 156.25\text{MHz}$ Square Wave, $V_{PP} = 0.5V$, Integration Range: 1kHz - 40MHz		54	72	fs
		$f_{REF} = 156.25\text{MHz}$ Square Wave, $V_{PP} = 0.5V$, Integration Range: 10kHz - 20MHz		42	55	fs
		$f_{REF} = 156.25\text{MHz}$ Square Wave, $V_{PP} = 0.5V$, Integration Range: 12kHz - 20MHz		42	55	fs

NOTE: Electrical parameters are guaranteed over the specified ambient operating temperature range, which is established when the device is mounted in a test socket with maintained transverse airflow greater than 500 lpm. The device will meet specifications after thermal equilibrium has been reached under these conditions.

Table 4C. Buffer Additive Phase Jitter, t_{JIT} , $2.5V \pm 5\%$, $V_{EE} = 0V$, $T_A = -40^\circ C$ to $85^\circ C$

Symbol	Parameter	Test Conditions	Minimum	Typical	Maximum	Units
t_{JIT}	Buffer Additive Phase Jitter, RMS; refer to Additive Phase Jitter Section	$f_{REF} = 122.88\text{MHz}$ Square Wave, $V_{PP} = 1V$, Integration Range: 1kHz - 40MHz		103	119	fs
		$f_{REF} = 122.88\text{MHz}$ Square Wave, $V_{PP} = 1V$, Integration Range: 10kHz - 20MHz		64	85	fs
		$f_{REF} = 122.88\text{MHz}$ Square Wave, $V_{PP} = 1V$, Integration Range: 12kHz - 20MHz		64	84	fs
		$f_{REF} = 156.25\text{MHz}$ Square Wave, $V_{PP} = 1V$, Integration Range: 1kHz - 40MHz		66	79	fs
		$f_{REF} = 156.25\text{MHz}$ Square Wave, $V_{PP} = 1V$, Integration Range: 10kHz - 20MHz		48	57	fs
		$f_{REF} = 156.25\text{MHz}$ Square Wave, $V_{PP} = 1V$, Integration Range: 12kHz - 20MHz		48	57	fs
		$f_{REF} = 156.25\text{MHz}$ Square Wave, $V_{PP} = 0.5V$, Integration Range: 1kHz - 40MHz		58	79	fs
		$f_{REF} = 156.25\text{MHz}$ Square Wave, $V_{PP} = 0.5V$, Integration Range: 10kHz - 20MHz		45	60	fs
		$f_{REF} = 156.25\text{MHz}$ Square Wave, $V_{PP} = 0.5V$, Integration Range: 12kHz - 20MHz		45	60	fs

NOTE: Electrical parameters are guaranteed over the specified ambient operating temperature range, which is established when the device is mounted in a test socket with maintained transverse airflow greater than 500 lpm. The device will meet specifications after thermal equilibrium has been reached under these conditions. Additive Phase Jitter

Additive Phase Jitter

The spectral purity in a band at a specific offset from the fundamental compared to the power of the fundamental is called the ***dBc Phase Noise***. This value is normally expressed using a Phase noise plot and is most often the specified plot in many applications. Phase noise is defined as the ratio of the noise power present in a 1Hz band at a specified offset from the fundamental frequency to the power value of the fundamental. This ratio is expressed in decibels (dBm) or a ratio

of the power in the 1Hz band to the power in the fundamental. When the required offset is specified, the phase noise is called a ***dBc*** value, which simply means dBm at a specified offset from the fundamental. By investigating jitter in the frequency domain, we get a better understanding of its effects on the desired application over the entire time record of the signal. It is mathematically possible to calculate an expected bit error rate given a phase noise plot.

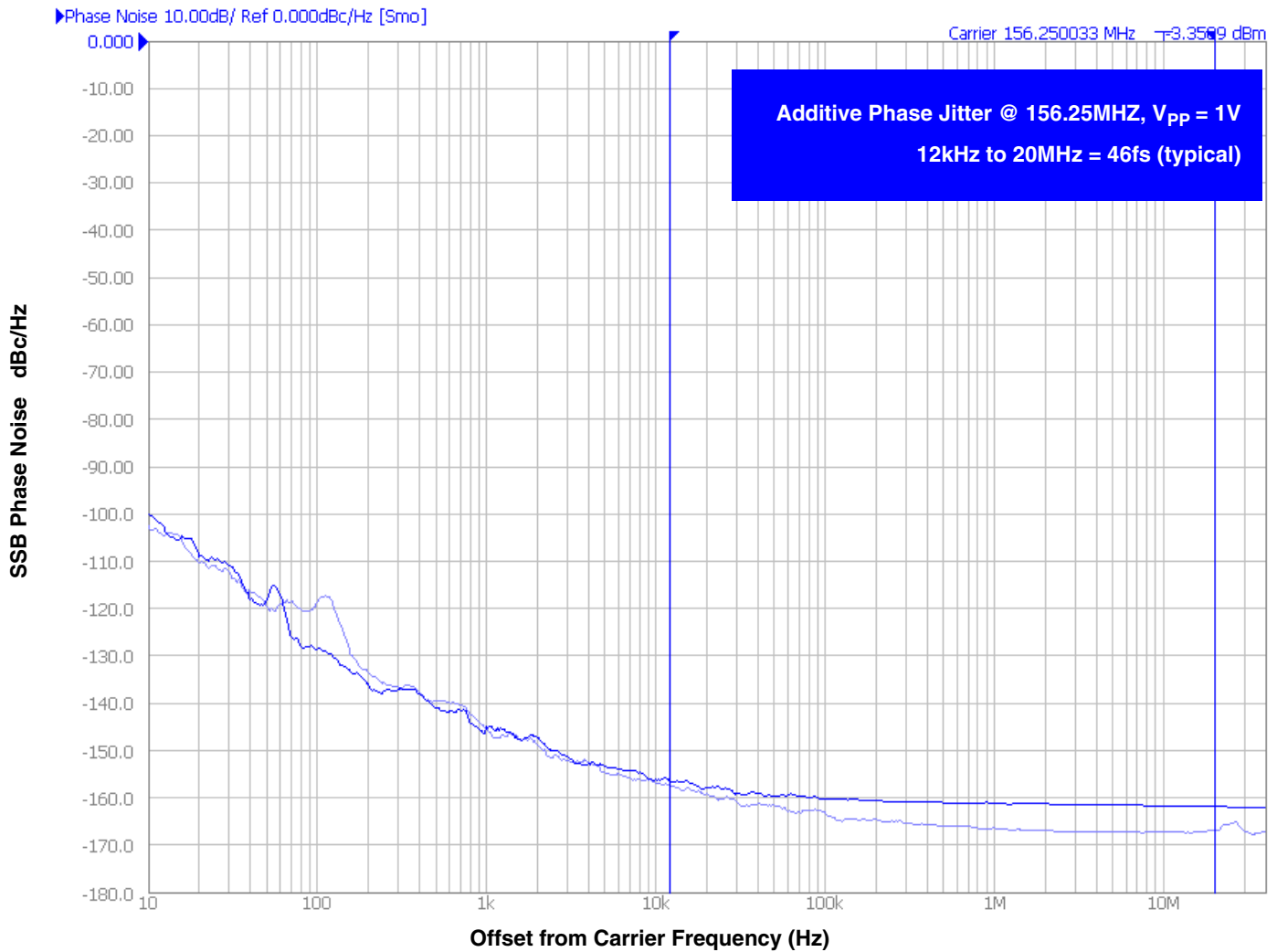

As with most timing specifications, phase noise measurements have issues relating to the limitations of the equipment. Often the noise floor of the equipment is higher than the noise floor of the device. This is illustrated above. The device meets the noise floor of what is shown, but can actually be lower. The phase noise is dependent on the input source and measurement equipment.

Measured using a Wenzel 156.25MHz Oscillator as the input source.

Parameter Measurement Information

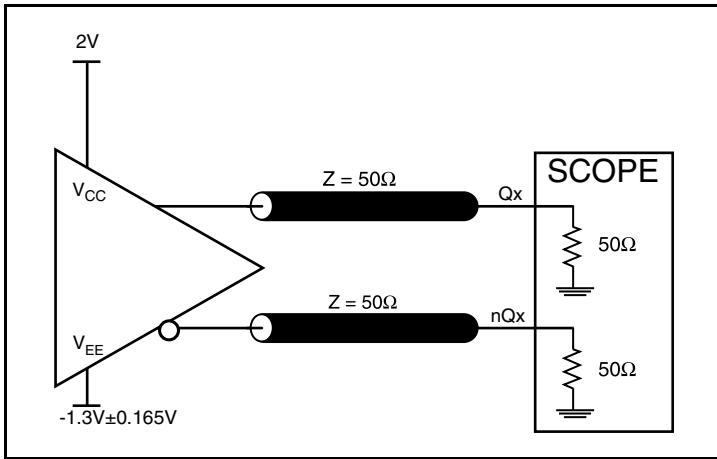

3.3V LVPECL Output Load Test Circuit

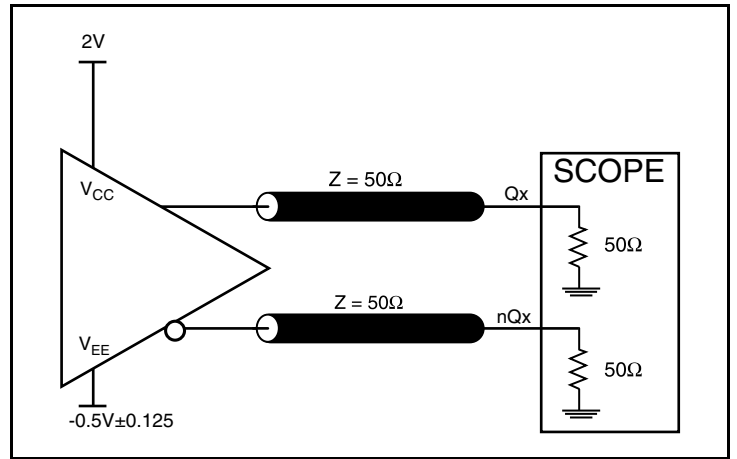

2.5V LVPECL Output Load Test Circuit

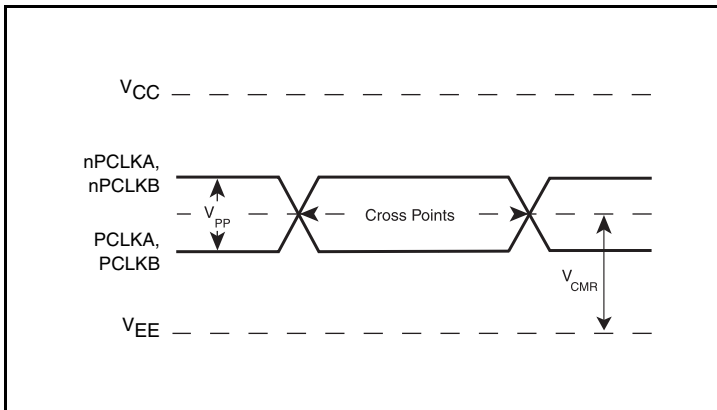

Differential Input Level

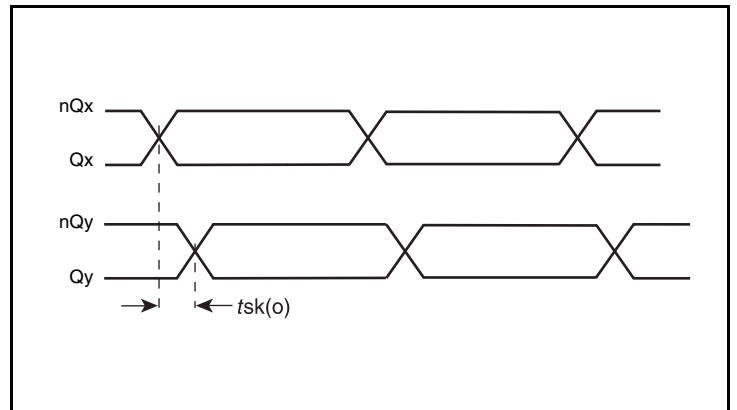

Output Skew

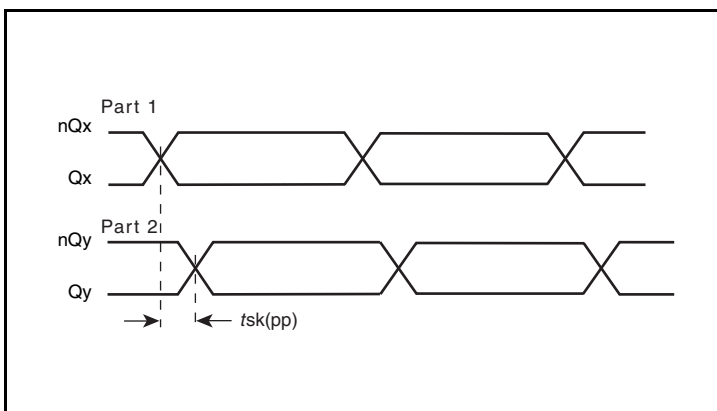

Part-to-Part Skew

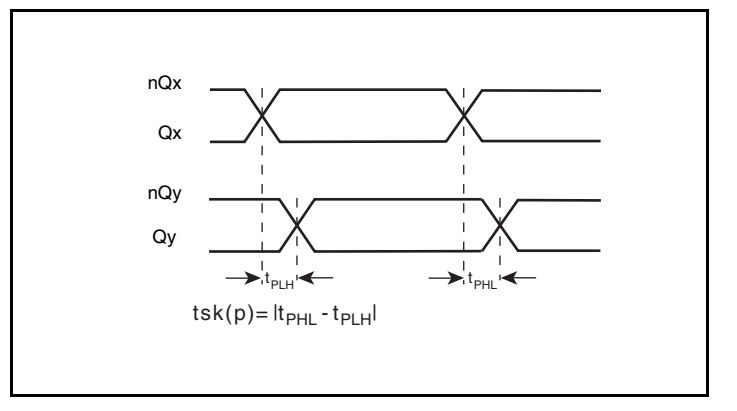

Pulse Skew

Parameter Measurement Information, continued

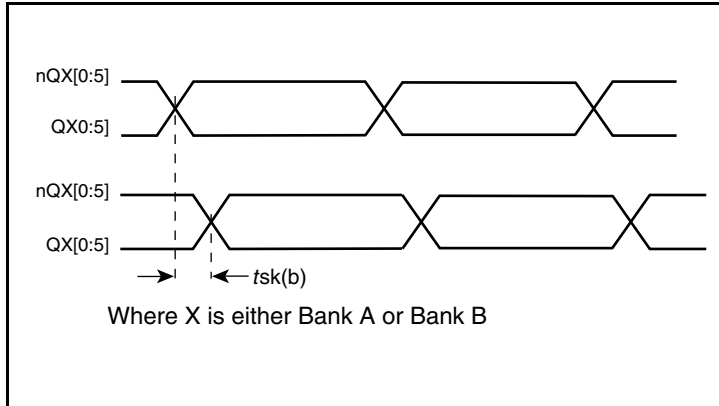

Bank Skew

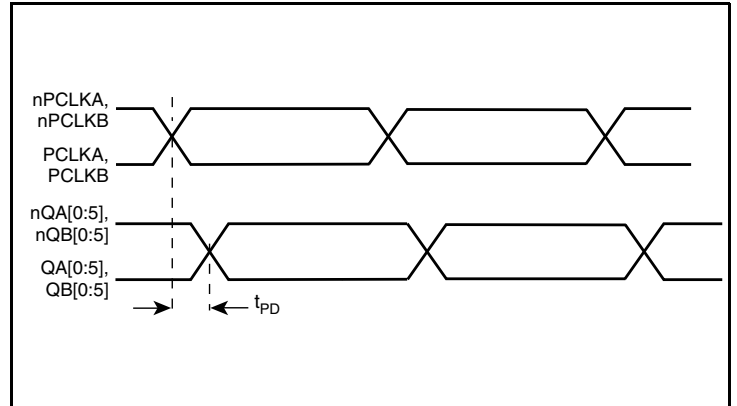

Propagation Delay

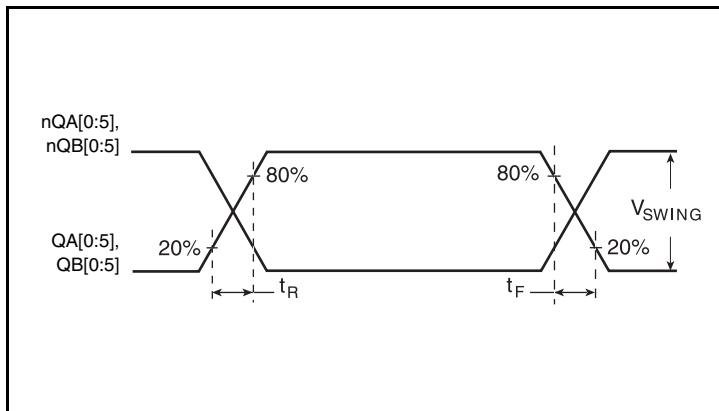

Output Rise/Fall Time

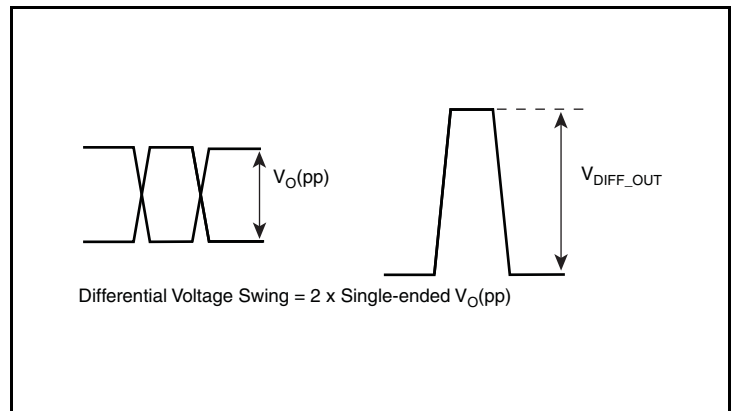

Differential Output Voltage Swing

Applications Information

Wiring the Differential Input to Accept Single-Ended Levels

The IDT8SLVP2106I inputs can be interfaced to LVPECL, LVDS, CML or LVC MOS drivers. *Figure 1A* illustrates how to dc couple a single LVC MOS input to the IDT8SLVP2106I. The value of the series resistance R_S is calculated as the difference between the transmission line impedance and the driver output impedance. This resistor should be placed close to the LVC MOS driver. To avoid cross-coupling of single-ended LVC MOS signals, apply the LVC MOS signals to no more than one PCLK input.

A practical method to implement V_{th} is shown in *Figure 1B* below. The reference voltage $V_{th} = V_1 = V_{CC}/2$, is generated by the bias resistors R_1 and R_2 . The bypass capacitor (C_1) is used to help filter noise on the DC bias. This bias circuit should be located as close to the input pin as possible.

The ratio of R_1 and R_2 might need to be adjusted to position the V_1 in the center of the input voltage swing. For example, if the input clock swing is 2.5V and $V_{CC} = 3.3V$, R_1 and R_2 value should be adjusted to set V_1 at 1.25V. The values below apply when both the single-ended swing and V_{CC} are at the same voltage.

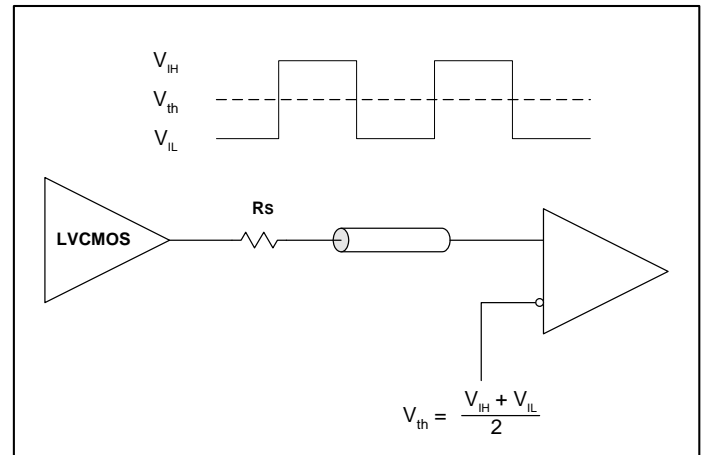

Figure 1A. DC-Coupling a Single LVC MOS Input to the IDT8SLVP2106I

When using single-ended signaling, the noise rejection benefits of differential signaling are reduced. Even though the differential input can handle full rail LVC MOS signaling, it is recommended that the amplitude be reduced, particularly if both input references are LVC MOS to minimize cross talk. The datasheet specifies a lower differential amplitude, however this only applies to differential signals. For single-ended applications, the swing can be larger, however V_{IL} cannot be less than $-0.3V$ and V_{IH} cannot be more than $V_{CC} + 0.3V$.

Figure 1B shows a way to attenuate the PCLK input level by a factor of two as well as matching the transmission line between the LVC MOS driver and the IDT8SLVP2106I at both the source and the

load. This configuration requires that the sum of the output impedance of the driver (R_o) and the series resistance (R_s) equals the transmission line impedance. R_3 and R_4 in parallel should equal the transmission line impedance; for most 50Ω applications, R_3 and R_4 will be 100Ω . The values of the resistors can be increased to reduce the loading for slower and weaker LVC MOS driver.

Though some of the recommended components of *Figure 1B* might not be used, the pads should be placed in the layout so that they can be utilized for debugging purposes. The datasheet specifications are characterized and guaranteed by using a differential signal.

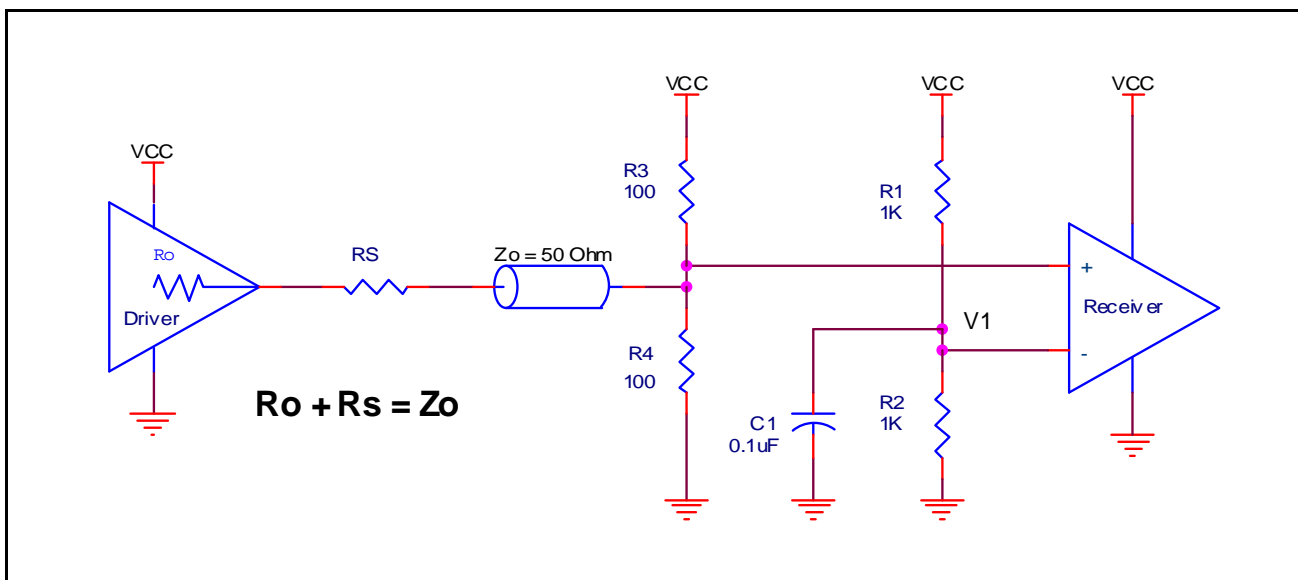

Figure 1B. Alternative DC Coupling a Single LVC MOS Input to the IDT8SLVP2106I

3.3V LVPECL Clock Input Interface

The PCLK /nPCLK accepts LVPECL, LVDS and other differential signals. Both differential signals must meet the V_{PP} and V_{CMR} input requirements. *Figures 2A to 2C* show interface examples for the PCLK /nPCLK input driven by the most common driver types. The

input interfaces suggested here are examples only. If the driver is from another vendor, use their termination recommendation. Please consult with the vendor of the driver component to confirm the driver termination requirements.

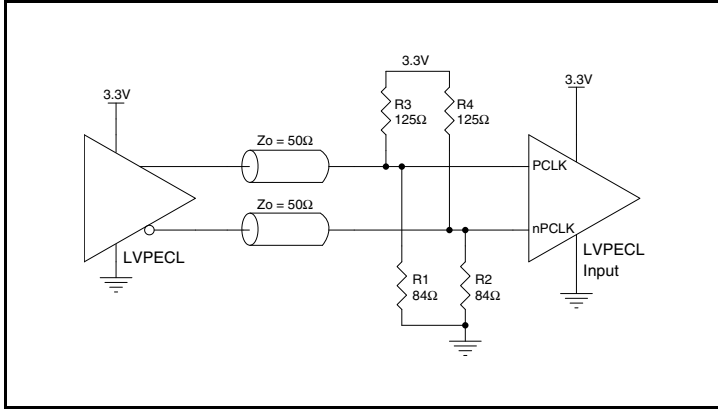

Figure 2A. PCLK/nPCLK Input Driven by a 3.3V LVPECL Driver

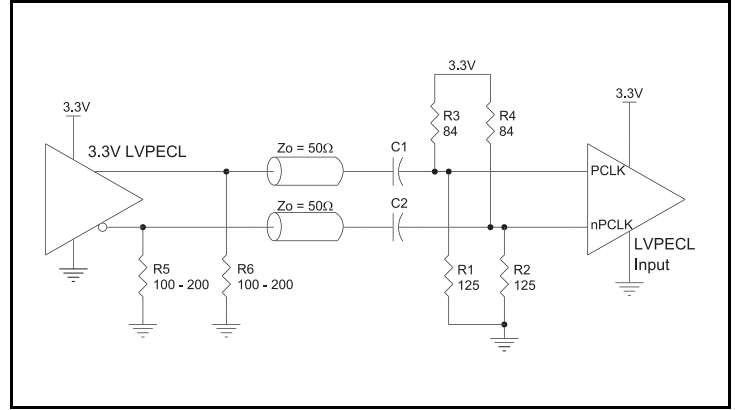

Figure 2B. PCLK/nPCLK Input Driven by a 3.3V LVPECL Driver with AC Couple

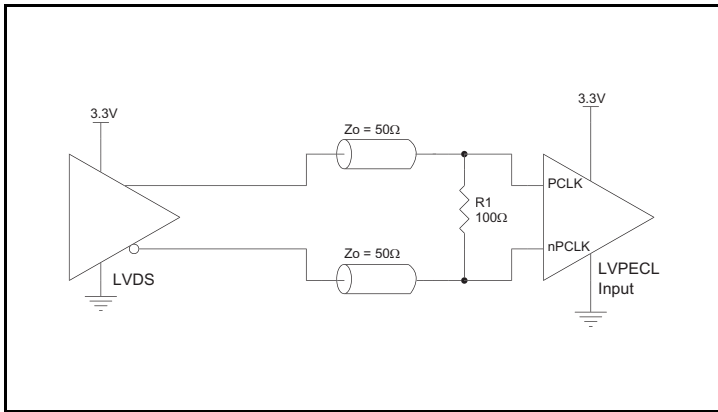

Figure 2C. PCLK/nPCLK Input Driven by a 3.3V LVDS Driver

2.5V LVPECL Clock Input Interface

The PCLK /nPCLK accepts LVPECL, LVDS and other differential signals. Both differential signals must meet the V_{PP} and V_{CMR} input requirements. *Figures 3A to 3C* show interface examples for the PCLK/ nPCLK input driven by the most common driver types. The

input interfaces suggested here are examples only. If the driver is from another vendor, use their termination recommendation. Please consult with the vendor of the driver component to confirm the driver termination requirements.

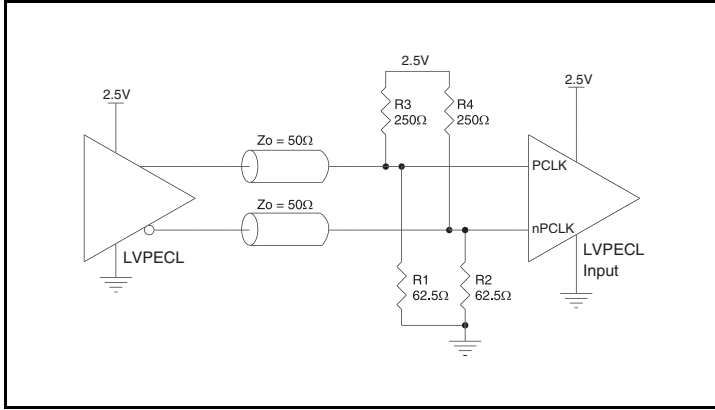

Figure 3A. PCLK/nPCLK Input Driven by a 2.5V LVPECL Driver

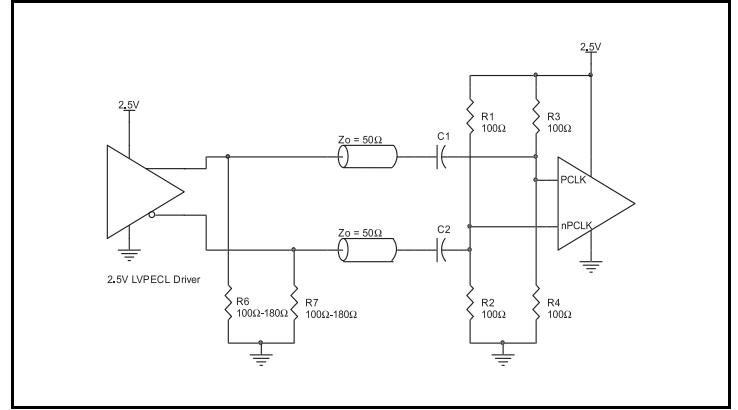

Figure 3B. PCLK/nPCLK Input Driven by a 2.5V LVPECL Driver with AC Couple

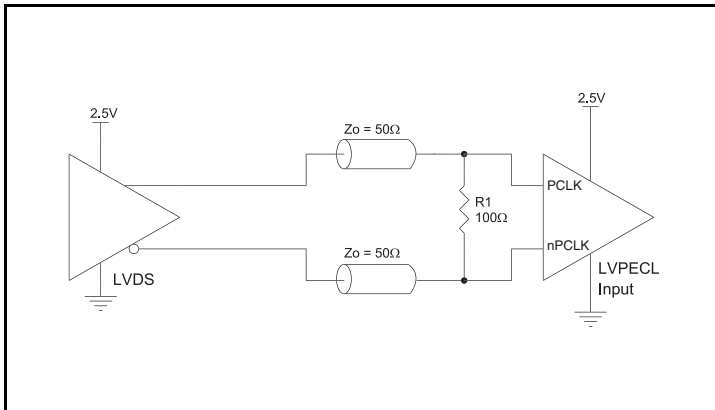

Figure 3C. PCLK/nPCLK Input Driven by a 2.5V LVDS Driver

Recommendations for Unused Input and Output Pins

Inputs:

PCLKx/nPCLKx Inputs

For applications requiring only one differential input, the unused PCLKx/nPCLKx input can be left floating. Though not required, but for additional protection, a 1k Ω resistor can be tied from the unused PCLKx input to ground.

Outputs:

LVPECL Outputs

All unused LVPECL outputs can be left floating. We recommend that there is no trace attached. Both sides of the differential output pair should either be left floating or terminated.

V_{REFX}

Unused V_{REFA} and V_{REFB} pins can be left floating. We recommend that there is no trace attached.

VFQFN EPAD Thermal Release Path

In order to maximize both the removal of heat from the package and the electrical performance, a land pattern must be incorporated on the Printed Circuit Board (PCB) within the footprint of the package corresponding to the exposed metal pad or exposed heat slug on the package, as shown in *Figure 4*. The solderable area on the PCB, as defined by the solder mask, should be at least the same size/shape as the exposed pad/slug area on the package to maximize the thermal/electrical performance. Sufficient clearance should be designed on the PCB between the outer edges of the land pattern and the inner edges of pad pattern for the leads to avoid any shorts.

While the land pattern on the PCB provides a means of heat transfer and electrical grounding from the package to the board through a solder joint, thermal vias are necessary to effectively conduct from the surface of the PCB to the ground plane(s). The land pattern must be connected to ground through these vias. The vias act as “heat pipes”. The number of vias (i.e. “heat pipes”) are application specific

and dependent upon the package power dissipation as well as electrical conductivity requirements. Thus, thermal and electrical analysis and/or testing are recommended to determine the minimum number needed. Maximum thermal and electrical performance is achieved when an array of vias is incorporated in the land pattern. It is recommended to use as many vias connected to ground as possible. It is also recommended that the via diameter should be 12 to 13mils (0.30 to 0.33mm) with 1oz copper via barrel plating. This is desirable to avoid any solder wicking inside the via during the soldering process which may result in voids in solder between the exposed pad/slug and the thermal land. Precautions should be taken to eliminate any solder voids between the exposed heat slug and the land pattern. Note: These recommendations are to be used as a guideline only. For further information, please refer to the Application Note on the Surface Mount Assembly of Amkor’s Thermally/Electrically Enhance Leadframe Base Package, Amkor Technology.

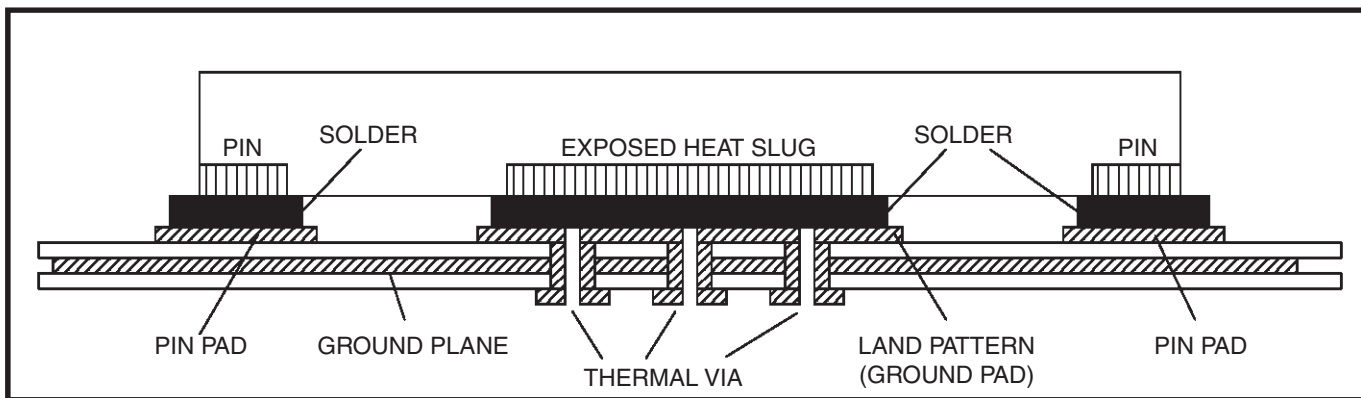

Figure 4. P.C. Assembly for Exposed Pad Thermal Release Path – Side View (drawing not to scale)

Termination for 3.3V LVPECL Outputs

The clock layout topology shown below is a typical termination for LVPECL outputs. The two different layouts mentioned are recommended only as guidelines.

The differential outputs are a low impedance follower output that generate ECL/LVPECL compatible outputs. Therefore, terminating resistors (DC current path to ground) or current sources must be used for functionality. These outputs are designed to drive 50Ω

transmission lines. Matched impedance techniques should be used to maximize operating frequency and minimize signal distortion.

Figures 5A and 5B show two different layouts which are recommended only as guidelines. Other suitable clock layouts may exist and it would be recommended that the board designers simulate to guarantee compatibility across all printed circuit and clock component process variations.

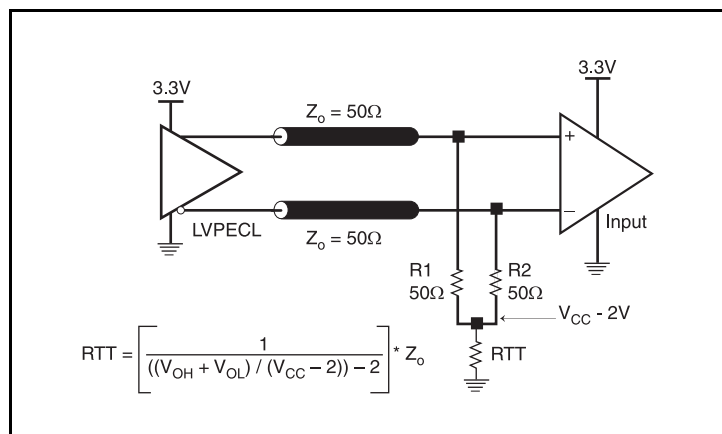

Figure 5A. 3.3V LVPECL Output Termination

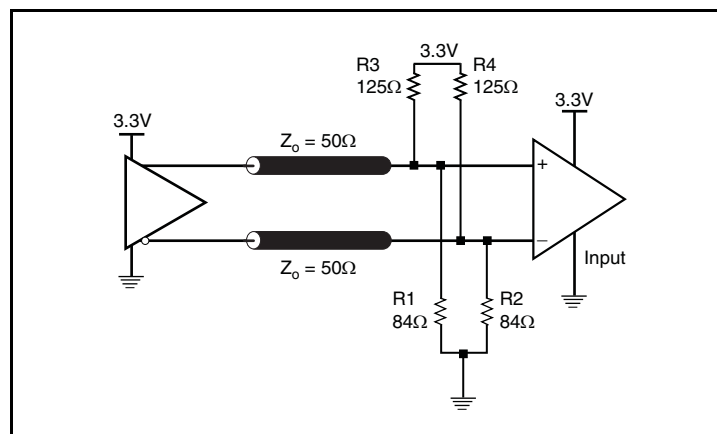

Figure 5B. 3.3V LVPECL Output Termination

Termination for 2.5V LVPECL Outputs

Figure 6A and Figure 6B show examples of termination for 2.5V LVPECL driver. These terminations are equivalent to terminating 50Ω to $V_{CC} - 2V$. For $V_{CC} = 2.5V$, the $V_{CC} - 2V$ is very close to ground

level. The R3 in Figure 6B can be eliminated and the termination is shown in Figure 6C.

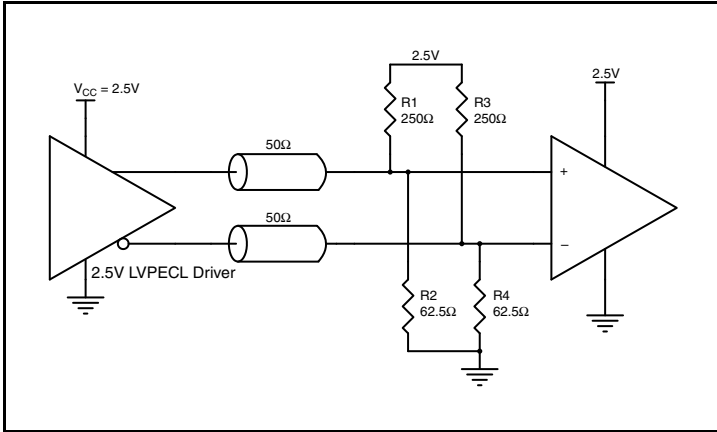

Figure 6A. 2.5V LVPECL Driver Termination Example

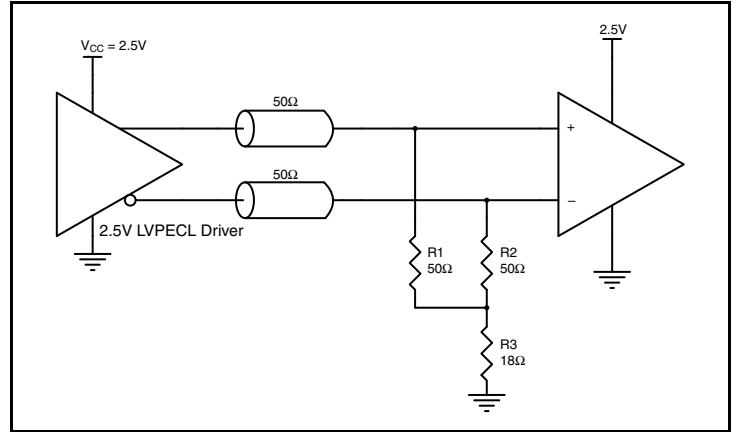

Figure 6B. 2.5V LVPECL Driver Termination Example

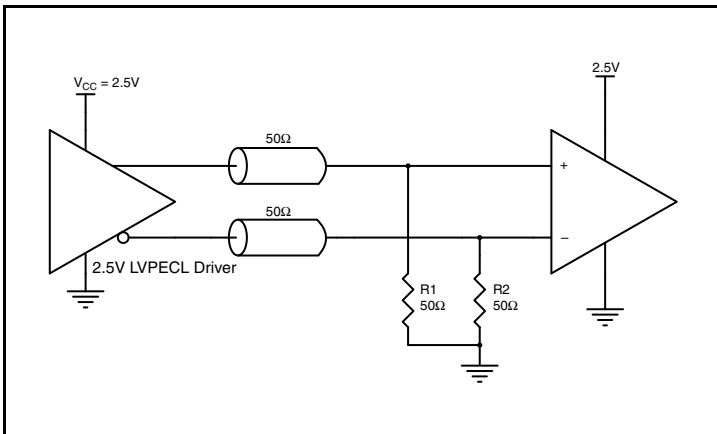

Figure 6C. 2.5V LVPECL Driver Termination Example

Power Considerations

This section provides information on power dissipation and junction temperature for the 8SLVP2106. Equations and example calculations are also provided.

1. Power Dissipation.

The total power dissipation for the 8SLVP2106 is the sum of the core power plus the power dissipated at the output(s). The following is the power dissipation for $V_{CC} = 3.465V$, which gives worst case results.

NOTE: Please refer to Section 3 for details on calculating power dissipated in the load.

$$\text{Power (core)}_{MAX} = V_{CC_MAX} * I_{EE_MAX} = 3.465V * 114mA = \mathbf{395mW}$$

- Power (outputs)_{MAX} = **37.1mW/Loaded Output pair**
If all outputs are loaded, the total power is $12 * 37.1mW = \mathbf{445.2mW}$

$$\text{Total Power}_{MAX} (3.465V, \text{ with all outputs switching}) = 395mW + 445.2mW = \mathbf{840mW}$$

2. Junction Temperature.

Junction temperature, T_j , is the temperature at the junction of the bond wire and bond pad directly affects the reliability of the device. The maximum recommended junction temperature is 125°C. Limiting the internal transistor junction temperature, T_j , to 125°C ensures that the bond wire and bond pad temperature remains below 125°C.

The equation for T_j is as follows: $T_j = \theta_{JA} * Pd_total + T_A$

T_j = Junction Temperature

θ_{JA} = Junction-to-Ambient Thermal Resistance

Pd_total = Total Device Power Dissipation (example calculation is in section 1 above)

T_A = Ambient Temperature

In order to calculate junction temperature, the appropriate junction-to-ambient thermal resistance θ_{JA} must be used. Assuming no air flow and a multi-layer board, the appropriate value is 38.1°C/W per Table 5 below.

Therefore, T_j for an ambient temperature of 85°C with all outputs switching is:

$$85^\circ\text{C} + 0.840W * 38.1^\circ\text{C/W} = 117^\circ\text{C}. \text{ This is below the limit of } 125^\circ\text{C}.$$

This calculation is only an example. T_j will obviously vary depending on the number of loaded outputs, supply voltage, air flow and the type of board (multi-layer).

Table 5. Thermal Resistance θ_{JA} for 40-Lead VFQFN, Forced Convection

Meters per Second	θ_{JA} by Velocity		
	0	1	2
Multi-Layer PCB, JEDEC Standard Test Boards	38.1°C/W	32°C/W	29.9°C/W

3. Calculations and Equations.

The purpose of this section is to calculate the power dissipation for the LVPECL output pair.

LVPECL output driver circuit and termination are shown in *Figure 7*.

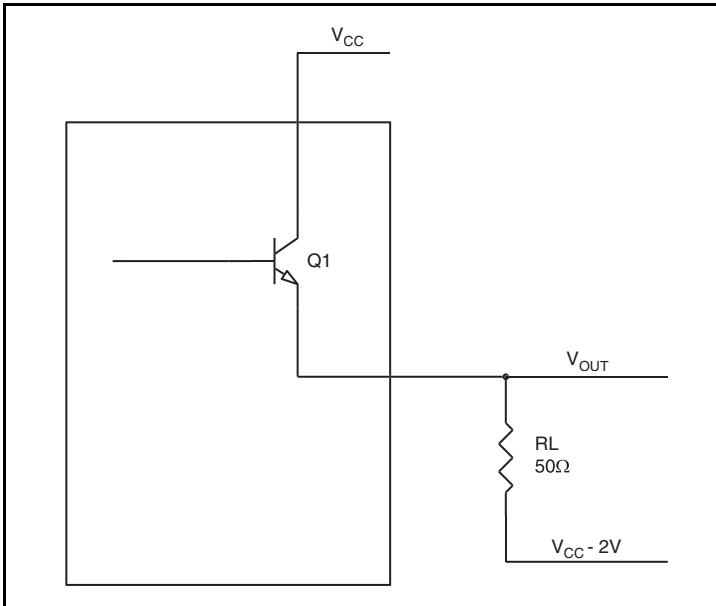

Figure 7. LVPECL Driver Circuit and Termination

To calculate worst case power dissipation at the output(s), use the following equations which assume a 50Ω load, and a termination voltage of $V_{CC} - 2V$. These are typical calculations.

- For logic high, $V_{OUT} = V_{OH_MAX} = V_{CC_MAX} - 0.72V$
 $(V_{CC_MAX} - V_{OH_MAX}) = 0.72V$
- For logic low, $V_{OUT} = V_{OL_MAX} = V_{CC_MAX} - 1.26V$
 $(V_{CC_MAX} - V_{OL_MAX}) = 1.26$

Pd_H is the power dissipation when the output drives high.

Pd_L is the power dissipation when the output drives low.

$$Pd_H = [(V_{OH_MAX} - (V_{CC_MAX} - 2V))/R_L] * (V_{CC_MAX} - V_{OH_MAX}) = [(2V - (V_{CC_MAX} - V_{OH_MAX}))/R_L] * (V_{CC_MAX} - V_{OH_MAX}) = [(2V - 0.72V)/50\Omega] * 0.72V = \mathbf{18.43mW}$$

$$Pd_L = [(V_{OL_MAX} - (V_{CC_MAX} - 2V))/R_L] * (V_{CC_MAX} - V_{OL_MAX}) = [(2V - (V_{CC_MAX} - V_{OL_MAX}))/R_L] * (V_{CC_MAX} - V_{OL_MAX}) = [(2V - 1.26V)/50\Omega] * 1.26V = \mathbf{18.65mW}$$

Total Power Dissipation per output pair = $Pd_H + Pd_L = \mathbf{37.1mW}$

Case Temperature Considerations

This device supports applications in a natural convection environment which does not have any thermal conductivity through ambient air. The printed circuit board (PCB) is typically in a sealed enclosure without any natural or forced air flow and is kept at or below a specific temperature. The device package design incorporates an exposed pad (ePad) with enhanced thermal parameters which is soldered to the PCB where most of the heat escapes from the bottom exposed pad. For this type of application, it is recommended to use the junction-to-board thermal characterization parameter Ψ_{JB} (Psi-JB) to calculate the junction temperature (T_J) and ensure it does not exceed the maximum allowed junction temperature in the Absolute Maximum Rating table.

The junction-to-board thermal characterization parameter, Ψ_{JB} , is calculated using the following equation:

$$T_J = T_{CB} + \Psi_{JB} \times P_d, \text{ Where}$$

T_J = Junction temperature at steady state condition in ($^{\circ}\text{C}$).

T_{CB} = Case temperature (Bottom) at steady state condition in ($^{\circ}\text{C}$).

Ψ_{JB} = Thermal characterization parameter to report the difference between junction temperature and the temperature of the board measured at the top surface of the board.

P_d = power dissipation (W) in desired operating configuration.

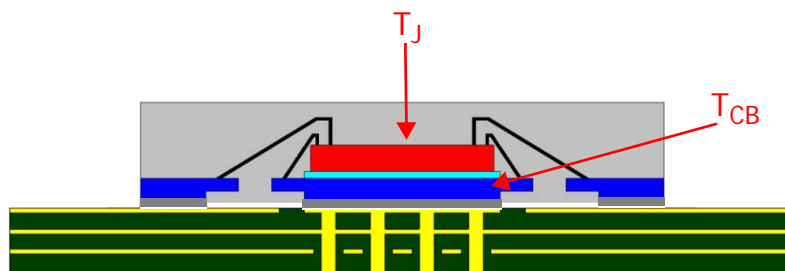

The ePad provides a low thermal resistance path for heat transfer to the PCB and represents the key pathway to transfer heat away from the IC to the PCB. It's critical that the connection of the exposed pad to the PCB is properly constructed to maintain the desired IC case temperature (T_{CB}). A good connection ensures that temperature at the exposed pad (T_{CB}) and the board temperature (T_B) are relatively the same. An improper connection can lead to increased junction temperature, increased power consumption and decreased electrical performance. In addition, there could be long-term reliability issues and increased failure rate.

Example Calculation for Junction Temperature (T_J): $T_J = T_{CB} + \Psi_{JB} \times P_d$

Package type:	40-Lead VFQFN
Body size:	6mm x 6mm x 0.925mm
ePad size:	2.9mm x 2.9mm
Thermal Via:	4 x 4 matrix
Ψ_{JB}	1.5 C/W
T_{CB}	105 $^{\circ}\text{C}$
P_d	0.840 W

For the variables above, the junction temperature is equal to 106.3 $^{\circ}\text{C}$. Since this is below the maximum junction temperature of 125 $^{\circ}\text{C}$, there are no long term reliability concerns. In addition, since the junction temperature at which the device was characterized using forced convection is 117 $^{\circ}\text{C}$, this device can function without the degradation of the specified AC or DC parameters.

Reliability Information

Table 6. θ_{JA} vs. Air Flow Table for a 40 Lead VFQFN

θ_{JA} at 0 Air Flow			
Meters per Second	0	1	2
Multi-Layer PCB, JEDEC Standard Test Boards	38.1°C/W	32°C/W	29.9°C/W

Transistor Count

The transistor count for the 8SLVP2106 is: 7706

40-Lead VFQFN Package Outline and Package Dimensions

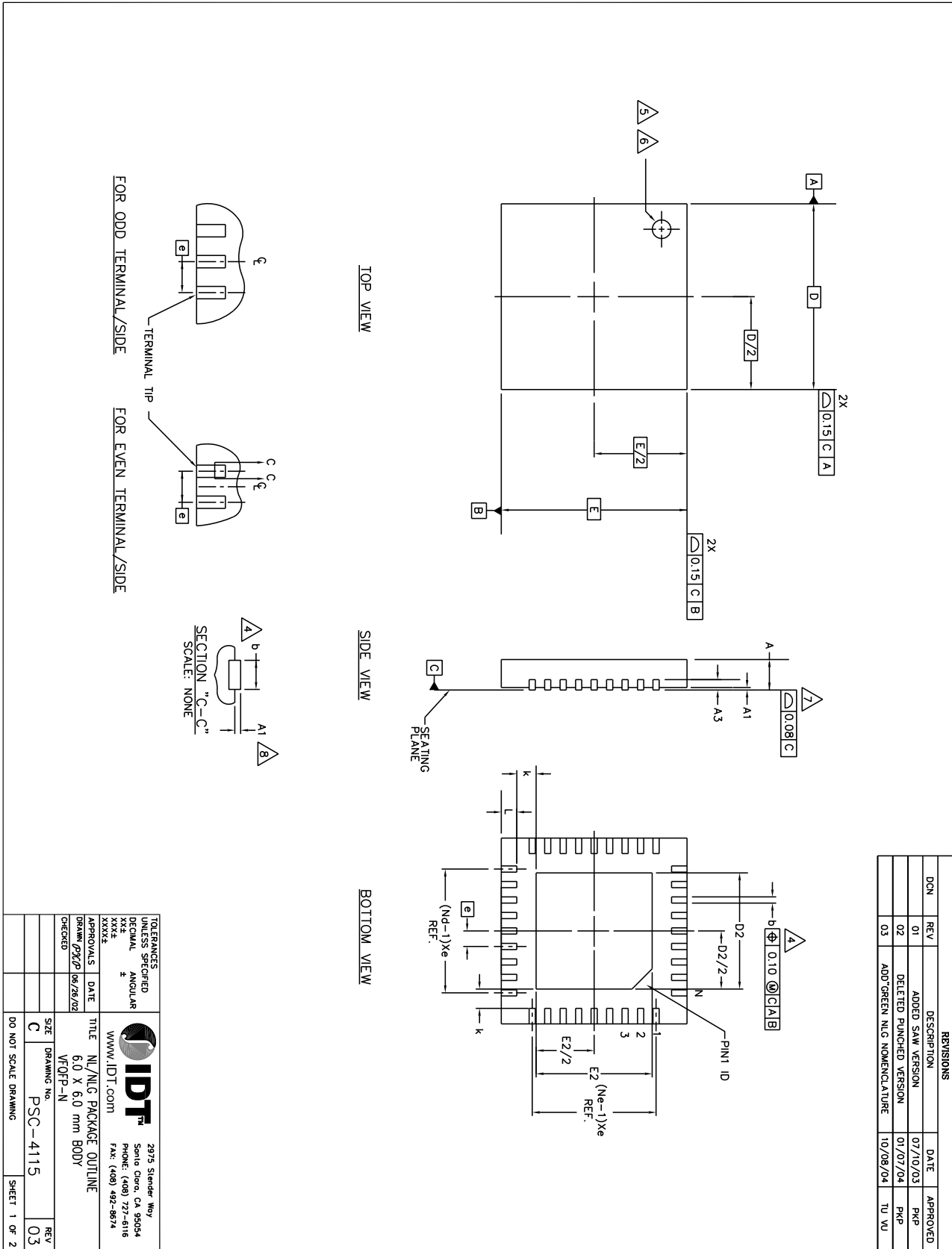

40-Lead VFQFN Package Outline and Package Dimensions, continued

Symbol	JEDEC VARIATION VJUC-3			Symbol	JEDEC VARIATION VJUD-5		
	MIN.	NOM.	MAX.		MIN.	NOM.	MAX.
θ	0.65	BSC			0.50	BSC	
N	28				40		
Nd	7				10		
Ne	2				2		
b	0.25	0.30	0.35		0.18	0.25	0.30
D2							
E2							

Symbol	COMMON DIMENSIONS		
	MIN.	NOM.	MAX.
A	0.00	0.90	1.00
A1		0.02	0.05
A3		0.20	REF.
D		6.00	BSC
E	0.20		BSC
K	0.35		
L		0.40	0.45

REVISIONS				
DCN	REV	DESCRIPTION	DATE	APPROVED
	01	ADDED SAW VERSION	07/10/03	RKP
	02	DELETED PUNCHED VERSION	01/07/04	RKP
	03	ADD "GREEN" NIG NOMENCLATURE	10/08/04	TU VU

NOTES:

1. DIMENSIONING & TOLERANCING CONFORM TO ASME Y14.5M - 1994.
2. N IS THE NUMBER OF TERMINALS.
Nd IS THE NUMBER OF TERMINALS IN X-DIRECTION & Ne IS THE NUMBER OF TERMINALS IN Y-DIRECTION.
3. ALL DIMENSIONS ARE IN MILLIMETERS.
4. DIMENSION b APPLIES TO PLATED TERMINAL AND IS MEASURED BETWEEN 0.20 AND 0.30mm FROM TERMINAL TIP.
5. THE PIN #1 IDENTIFIER MUST EXIST ON THE TOP SURFACE OF THE PACKAGE BY USING INDENTATION MARK OR OTHER FEATURE OF PACKAGE BODY.
6. EXACT SHAPE AND SIZE OF THIS FEATURE IS OPTIONAL.
7. APPLIED TO EXPOSED PAD AND TERMINALS. EXCLUDE EMBEDDED PART OF EXPOSED PAD FROM MEASURING.
8. APPLIED ONLY FOR TERMINALS.
9. THIS OUTLINES CONFORMS TO JEDEC PUBLICATION 95 REGISTRATION MO-220, VARIATION VJUC-3 & VJUD-5 WITH THE EXCEPTION OF D2 & E2.
10. DIMENSIONS D2 & E2 VARY DEPENDING ON DEVICE, SUPPLIER, ETC.

40-lead VFQFN, D2/E2 EPAD Dimensions: 2.9mm x 2.9mm

TOLERANCES UNLESS SPECIFIED		2975 Steiner Way	
DECIMAL	ANGULAR	Santa Clara, CA 95054	
XXX	±	PHONE: (408) 727-6116	
XXX		FAX: (408) 492-8674	
APPROVALS		WWW.IDT.COM	
DRAWN	DATE	TITLE	
PTP	06/26/02	NL/NIG PACKAGE OUTLINE	
CHECKED		VFQFN-N	
SIZE	DRAWING NO.	REV	
C	PSC-4115	03	
DO NOT SCALE DRAWING			SHEET 2 OF 2

Ordering Information

Table 7. Ordering Information

Part/Order Number	Marking	Package	Shipping Packaging	Temperature
8SLVP2106ANLGI	IDT8SLVP2106ANLGI	"Lead-Free" 40-Lead VFQFN	Tray	-40°C to 85°C
8SLVP2106ANLGI8	IDT8SLVP2106ANLGI	"Lead-Free" 40-Lead VFQFN	Tape & Reel, Pin 1 Orientation: EIA-481-C	-40°C to 85°C
8SLVP2106ANLGI/W	IDT8SLVP2106ANLGI	"Lead-Free" 40-Lead VFQFN	Tape & Reel, Pin 1 Orientation: EIA-481-D	-40°C to 85°C

NOTE: Parts that are ordered with an "G" suffix to the part number are the Pb-Free configuration and are RoHS compliant.

Table 8. Pin 1 Orientation in Tape and Reel Packaging

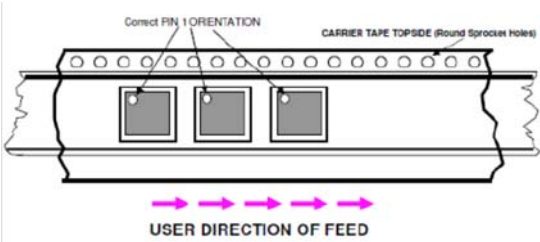
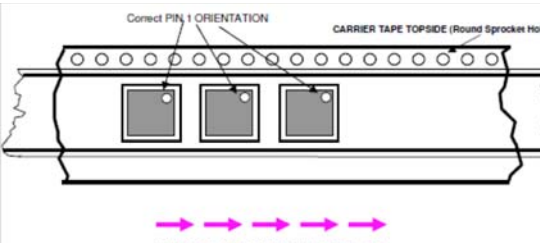
Part Number Suffix	Pin 1 Orientation	Illustration
8	Quadrant 1 (EIA-481-C)	
/W	Quadrant 2 (EIA-481-D)	

Revision History Sheet

Rev	Table	Page	Description of Change	Date
A	T7, T8	21	Ordering Information Table - added additional row. Added Orientation Packaging Table.	8/02/2012
A	T4A	1 5 10	Features section - added Differential PCLK bullets. AC Characteristics Notes, added NOTE 7. Updated application note, <i>Wiring the Differential Inputs to Accept Single-ended Levels</i> .	10/29/2012
A	T4A	5	Changed Note 8 to read "V _{IL} should not be less than -0.3V. V _{IH} should not be higher than V _{CC} ."	1/28/2014
B		1 18	Features Section - added Case Temperature bullet. Added Case Temperature section. Updated data sheet format.	6/9/15



Corporate Headquarters
6024 Silver Creek Valley Road
San Jose, CA 95138 USA

Sales
1-800-345-7015 or 408-284-8200
Fax: 408-284-2775
www.IDT.com

Tech Support
email: clocks@idt.com

DISCLAIMER Integrated Device Technology, Inc. (IDT) and its subsidiaries reserve the right to modify the products and/or specifications described herein at any time and at IDT's sole discretion. All information in this document, including descriptions of product features and performance, is subject to change without notice. Performance specifications and the operating parameters of the described products are determined in the independent state and are not guaranteed to perform the same way when installed in customer products. The information contained herein is provided without representation or warranty of any kind, whether express or implied, including, but not limited to, the suitability of IDT's products for any particular purpose, an implied warranty of merchantability, or non-infringement of the intellectual property rights of others. This document is presented only as a guide and does not convey any license under intellectual property rights of IDT or any third parties.

IDT's products are not intended for use in applications involving extreme environmental conditions or in life support systems or similar devices where the failure or malfunction of an IDT product can be reasonably expected to significantly affect the health or safety of users. Anyone using an IDT product in such a manner does so at their own risk, absent an express, written agreement by IDT.

While the information presented herein has been checked for both accuracy and reliability, Integrated Device Technology (IDT) assumes no responsibility for either its use or for the infringement of any patents or other rights of third parties, which would result from its use. No other circuits, patents, or licenses are implied. This product is intended for use in normal commercial applications. Any other applications, such as those requiring extended temperature ranges, high reliability or other extraordinary environmental requirements are not recommended without additional processing by IDT. IDT reserves the right to change any circuitry or specifications without notice. IDT does not authorize or warrant any IDT product for use in life support devices or critical medical instruments.

Integrated Device Technology, IDT and the IDT logo are registered trademarks of IDT. Product specification subject to change without notice. Other trademarks and service marks used herein, including protected names, logos and designs, are the property of IDT or their respective third party owners.

Copyright ©2015 Integrated Device Technology, Inc.. All rights reserved.