

Description

The GM339 consists of four independent precision voltage comparators which were designed specifically to operate from a single power supply over a wide range of voltages. Operation from split power supplies is also possible and the low power supply current drain is independent of the magnitude of the power supply voltage. These comparators also have a unique characteristic. In that, the input common-mode voltage range includes ground, even though operated from a single power supply voltage.

Application areas include limit comparators, simple analog to digital converters; pulse, square wave and time delay generators; wide range VCO; MOS clock timers; multivibrators and high voltage digital logic gates. The GM339 are designed to directly interface with TTL and CMOS. When operated from both plus and minus power supplies, the GM339 will directly interface with MOS logic, where their low power drain is a distinct advantage over standard comparators.

The GM339 is available in DIP-8 and SOP-8 packages.

Features

- ◆ Single- supply Range: $\pm 1.0V$ to $\pm 18V$
- ◆ Wide supply voltage range: $\pm 2.0V$ to $\pm 36V$
- ◆ Very low supply current drain (0.4 mA) - independent of supply voltage
- ◆ Low input biasing current: 25 nA
- ◆ Low input offset current: ± 5 nA
- ◆ Maximum offset voltage: ± 3 mV
- ◆ Input common-mode voltage range includes ground
- ◆ Differential input voltage range equal to the power supply voltage
- ◆ Low output saturation voltage: 250 mV at 4 mA
- ◆ Output voltage compatible with TTL, DTL, ECL, MOS and CMOS logic systems

Connecting Diagram

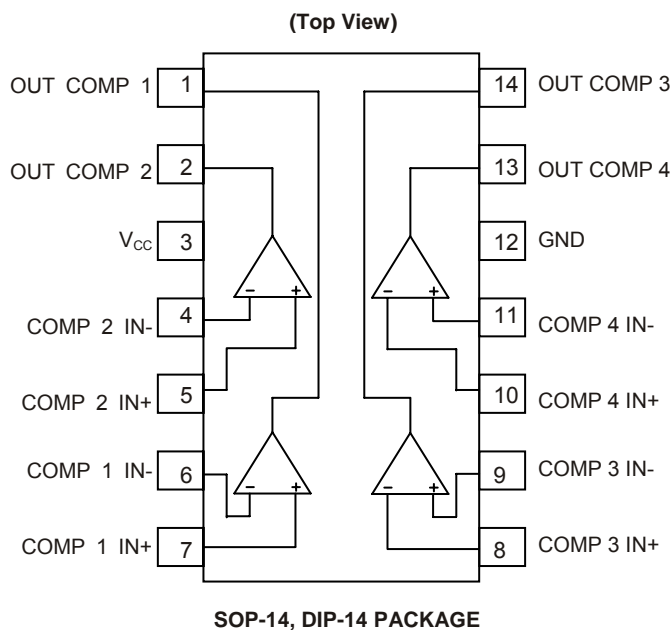

Marking Information and Pin Configurations (Top View)

SO14 and DIP14

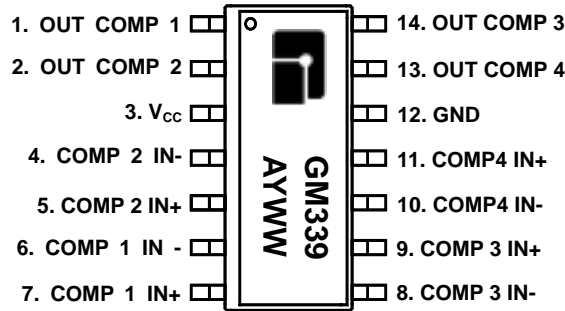

A: Assembly / Test site code
Y: Year
WW: Week

Ordering Information

Ordering Number	Package	Shipping
GM339D14T	DIP-14	25 Units / Tube
GM339S14T	SO-14	50 Units / Tube
GM339S14R	SO-14	2,500 Units / Tape & Reel

Absolute Maximum Ratings

PARAMETER	RATINGS	UNITS
Supply Voltage	± 18 or 36	V
Input Current	50	mA
Input Voltage	-0.3 to +32	V
Operating Temperature Range	-40 to 125	
Storage Temperature	- 65 to 150	
Lead Temperature (soldering 10 sec.)	260	

Block Diagram

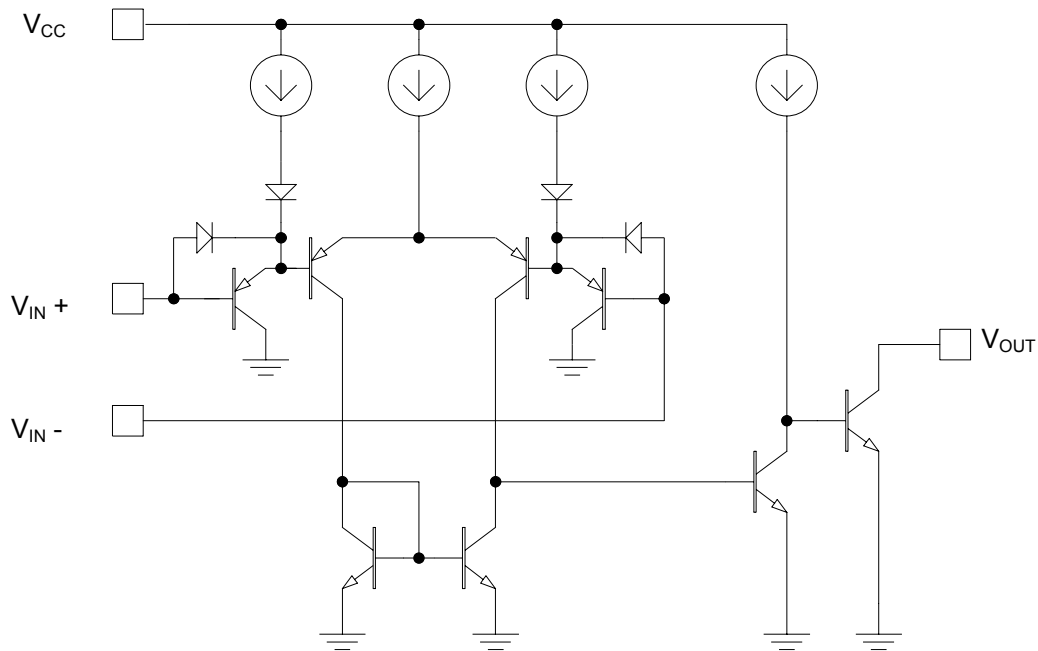

Electrical Characteristics ($V_{CC} = 5V$, at specified free-air temperature, unless otherwise specified)

Parameter	Symbol	Condition	Min	Typ	Max	Unit	
Input offset Voltage	V_{IO}	$V_{CC} = 5V$ to Max $V_{IC} = V_{ICR}$ min $V_O = 1.4V$	$T_A = 25$		± 2	± 5	mV
			Full Range			9	
Input Offset Current	I_{IO}	$V_O = 1.4V$	$T_A = 25$		± 5	± 50	nA
			Full Range			± 150	
Input Bias Current	I_{IB}	$V_O = 1.4V$	$T_A = 25$		-20	-250	nA
			Full Range			400	
Common-Mode Input Voltage Range**	V_{ICR}		$T_A = 25$	0 to $V_{CC}-1.5V$			V
			Full Range	0 to $V_{CC}-2.0V$			
Low-Level output Voltage	V_{OL}	$I_{OL} = 4mA$, $V_{ID} = 1V$	$T_A = 25$		150	400	mV
			Full Range			700	
Large-Signal Differential Voltage Amplification	A_{VD}	$V_{CC} = 15V$, $V_O = 1V$ to $11V$ $R_L = 15K$ to V_{CC}	$T_A = 25$	50	200		V/mV
High Level Output Current	I_{OH}	$V_{OH} = 5V$, $V_{ID} = 1V$	$T_A = 25$		0.1	50	nA
		$V_{OH} = 30V$, $V_{ID} = 1V$	Full Range		1		μA
Low Level Output Current	I_{OL}	$V_{OH} = 1.5V$, $V_{ID} = -1V$	$T_A = 25$	6			mA
Supply Current	I_{CC}	$R_L = \infty$, $V_{CC} = 5V$	$T_A = 25$		0.8	1.0	mA
		$R_L = \infty$, $V_{CC} = 30V$	Full Range			2.5	
Response Time (Note 1)		R_L Connected to 5V through 5.1k. $C_L = 15pF$	100mV input step with 5mV overdrive		1.3		μs
			TTL - level input step		0.3		

All characteristics are measured under open loop conditions with zero common-mode input voltage unless otherwise specified. "MAX" V_{CC} for testing purposes is 30V. Full range is 0°C to 70°C.

** The voltage at either input or common - mode should not be allowed to go negative by more than 0.3V. The upper end of the common - mode voltage range is $V_{CC} - 1.5V$, but either or both inputs can go to 30V without damage.

Note 1: C_L includes probe and jig capacitance. The response time specified is the interval between the input step function and the instant when the output crosses 1.4V.

Typical Performance Characteristics

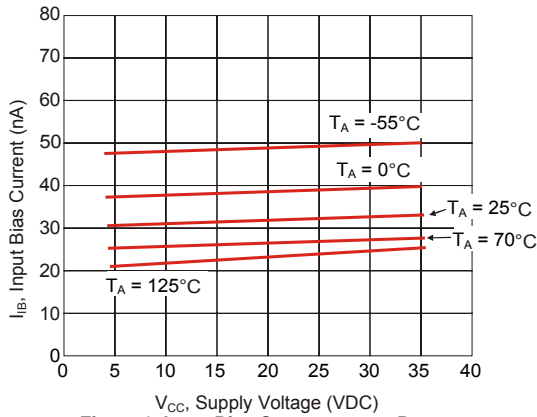

Figure 1. Input Bias Current versus Power Supply Voltage

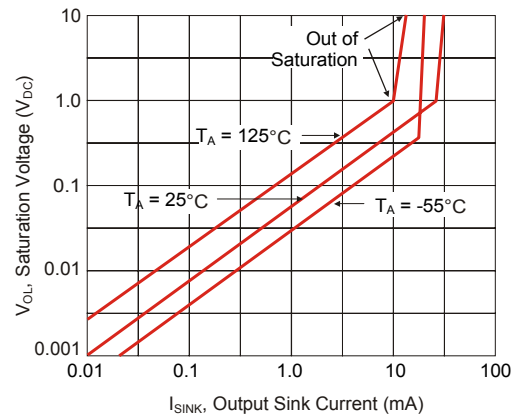

Figure 2. Output Saturation Voltage v.s. Output Sink Current

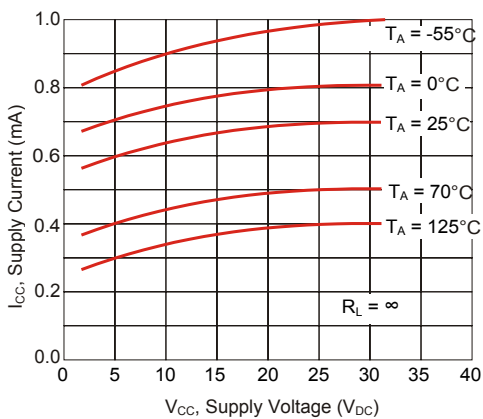
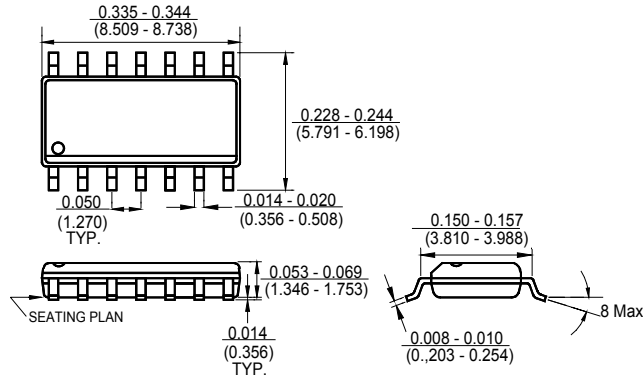
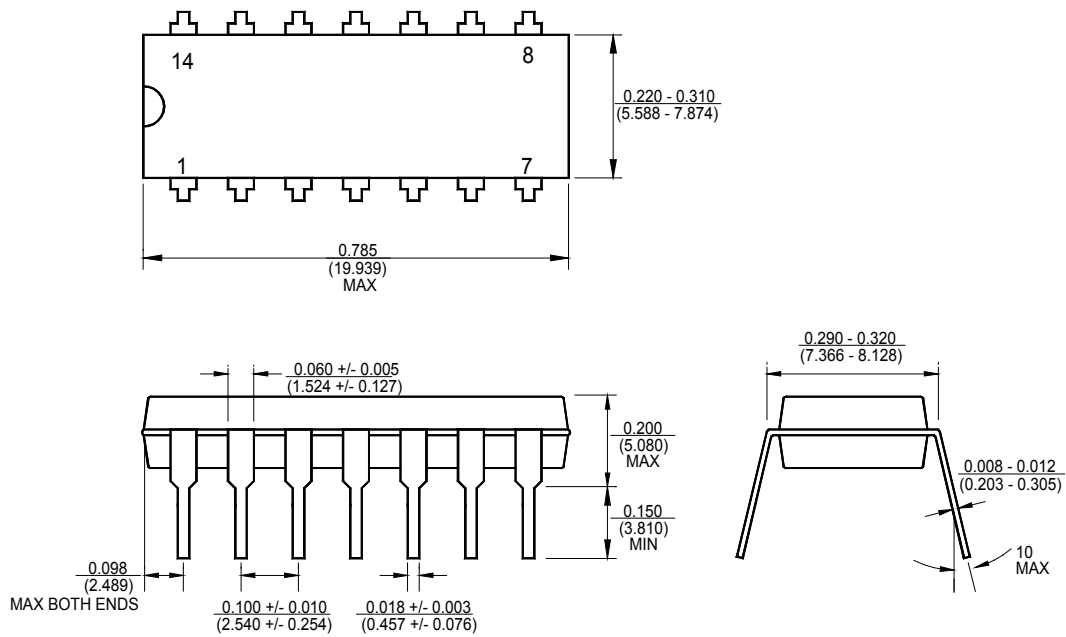

Figure 3. Power Supply Current versus Power Supply Voltage

Package Outline Dimensions – SO 14



Package Outline Dimensions – DIP 14



Ordering Number

GM 339 S14 R

APM Gamma Micro	Circuit Type	Package Type S14: SO 14 D14: DIP 14	Shipping Type R: Taping & Reel T: Tube
--------------------	--------------	--	--