

CZT955

**SURFACE MOUNT SILICON
HIGH CURRENT
PNP TRANSISTOR**



SOT-223 CASE



www.centrasemi.com

DESCRIPTION:

The CENTRAL SEMICONDUCTOR CZT955 is a silicon high current PNP transistor manufactured by the epitaxial planar process, epoxy molded in a surface mount package, designed for high voltage and high current amplifier applications.

MARKING: FULL PART NUMBER

MAXIMUM RATINGS: ($T_A=25^\circ\text{C}$)

Collector-Base Voltage
Collector-Emitter Voltage
Emitter-Base Voltage
Continuous Collector Current
Peak Collector Current
Power Dissipation (Note 1)
Operating and Storage Junction Temperature
Thermal Resistance

SYMBOL

V_{CB0}	180
V_{CEO}	140
V_{EBO}	7.0
I_C	4.0
I_{CM}	10
P_D	3.0
T_J, T_{stg}	-65 to +150
Θ_{JA}	41.7

UNITS

V
V
V
A
A
W
$^\circ\text{C}$
$^\circ\text{C/W}$

ELECTRICAL CHARACTERISTICS: ($T_A=25^\circ\text{C}$ unless otherwise noted)

SYMBOL	TEST CONDITIONS	MIN	TYP	MAX	UNITS
I_{CBO}	$V_{CB}=150\text{V}$			20	nA
I_{CBO}	$V_{CB}=150\text{V}, T_A=100^\circ\text{C}$			0.5	μA
I_{CER}	$V_{CE}=150\text{V}, R_{BE}\leq 1.0\text{k}\Omega$			20	nA
I_{EBO}	$V_{EB}=6.0\text{V}$			10	nA
BV_{CB0}	$I_C=100\mu\text{A}$	180	200		V
BV_{CER}	$I_C=1.0\mu\text{A}, R_{BE}\leq 1.0\text{k}\Omega$	180	200		V
BV_{CEO}	$I_C=10\text{mA}$	140	160		V
BV_{EBO}	$I_E=100\mu\text{A}$	7.0	8.0		V
$V_{CE(SAT)}$	$I_C=100\text{mA}, I_B=5.0\text{mA}$		40	60	mV
$V_{CE(SAT)}$	$I_C=0.5\text{A}, I_B=50\text{mA}$		55	80	mV
$V_{CE(SAT)}$	$I_C=1.0\text{A}, I_B=100\text{mA}$		85	120	mV
$V_{CE(SAT)}$	$I_C=3.0\text{A}, I_B=300\text{mA}$		210	360	mV
$V_{BE(SAT)}$	$I_C=3.0\text{A}, I_B=300\text{mA}$		0.96	1.04	V
$V_{BE(ON)}$	$V_{CE}=5.0\text{V}, I_C=3.0\text{A}$		830	930	mV
h_{FE}	$V_{CE}=5.0\text{V}, I_C=10\text{mA}$	100	250		
h_{FE}	$V_{CE}=5.0\text{V}, I_C=1.0\text{A}$	100	220	300	
h_{FE}	$V_{CE}=5.0\text{V}, I_C=3.0\text{A}$	35			
h_{FE}	$V_{CE}=5.0\text{V}, I_C=10\text{A}$		5.0		
f_T	$V_{CE}=10\text{V}, I_C=100\text{mA}, f=50\text{MHz}$		200		MHz
C_{ob}	$V_{CB}=10\text{V}, I_E=0, f=1.0\text{MHz}$		33		pF
t_{on}	$V_{CC}=50\text{V}, I_C=1.0\text{A}, I_{B1}=I_{B2}=0.1\text{A}$		25		ns
t_{off}	$V_{CC}=50\text{V}, I_C=1.0\text{A}, I_{B1}=I_{B2}=0.1\text{A}$		410		ns

Notes: (1) FR-4 Epoxy PC Board with copper mounting pad area of 4in^2 (minimum)

R2 (11-June 2013)

CZT955

**SURFACE MOUNT SILICON
HIGH CURRENT
PNP TRANSISTOR**



SOT-223 CASE - MECHANICAL OUTLINE

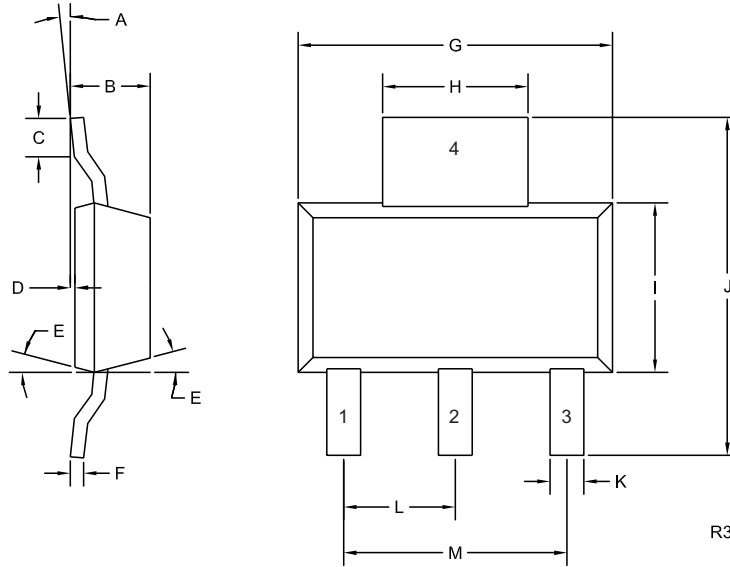

LEAD CODE:

- 1) Base
- 2) Collector
- 3) Emitter
- 4) Collector

MARKING:

FULL PART NUMBER

DIMENSIONS				
SYMBOL	INCHES		MILLIMETERS	
	MIN	MAX	MIN	MAX
A	0°	10°	0°	10°
B	0.059	0.071	1.50	1.80
C	0.018	—	0.45	—
D	0.000	0.004	0.00	0.10
E	15°		15°	
F	0.009	0.014	0.23	0.35
G	0.248	0.264	6.30	6.70
H	0.114	0.122	2.90	3.10
I	0.130	0.146	3.30	3.70
J	0.264	0.287	6.70	7.30
K	0.024	0.033	0.60	0.85
L	0.091		2.30	
M	0.181		4.60	

SOT-223 (REV: R3)

R2 (11-June 2013)

CZT955
SURFACE MOUNT SILICON
HIGH CURRENT
PNP TRANSISTOR



TYPICAL ELECTRICAL CHARACTERISTICS

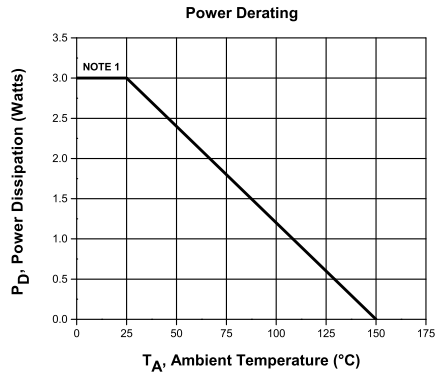
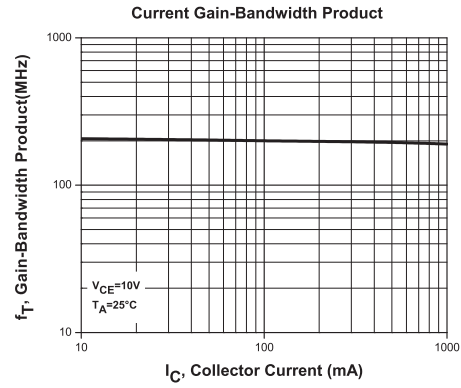
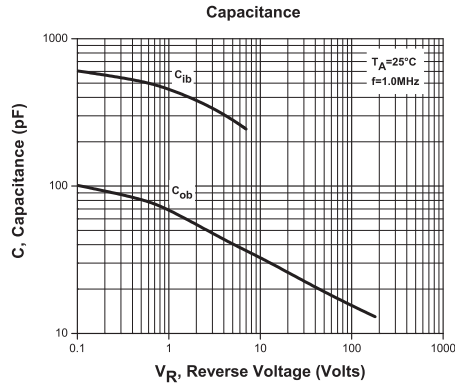
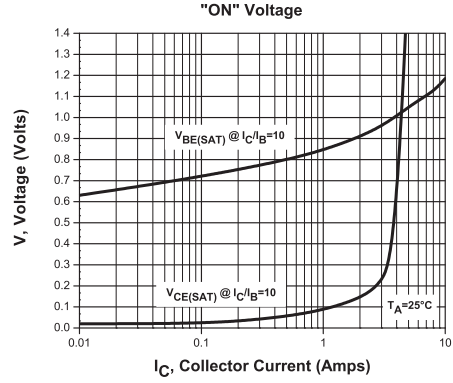
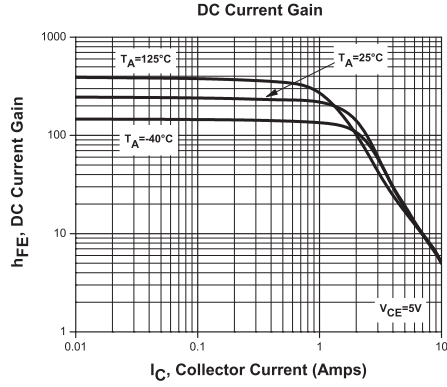

R2 (11-June 2013)