

THIS DRAWING IS UNPUBLISHED. RELEASED FOR PUBLICATION  
 © COPYRIGHT - By - ALL RIGHTS RESERVED.

| LOC |     | DIST                      |  | REVISIONS |     |      |  |
|-----|-----|---------------------------|--|-----------|-----|------|--|
| P   | LTR | DESCRIPTION               |  | DATE      | DWN | APVD |  |
|     | A1  | REVISED PER ECO-14-016841 |  | 07NOV2014 | NK  | RH   |  |

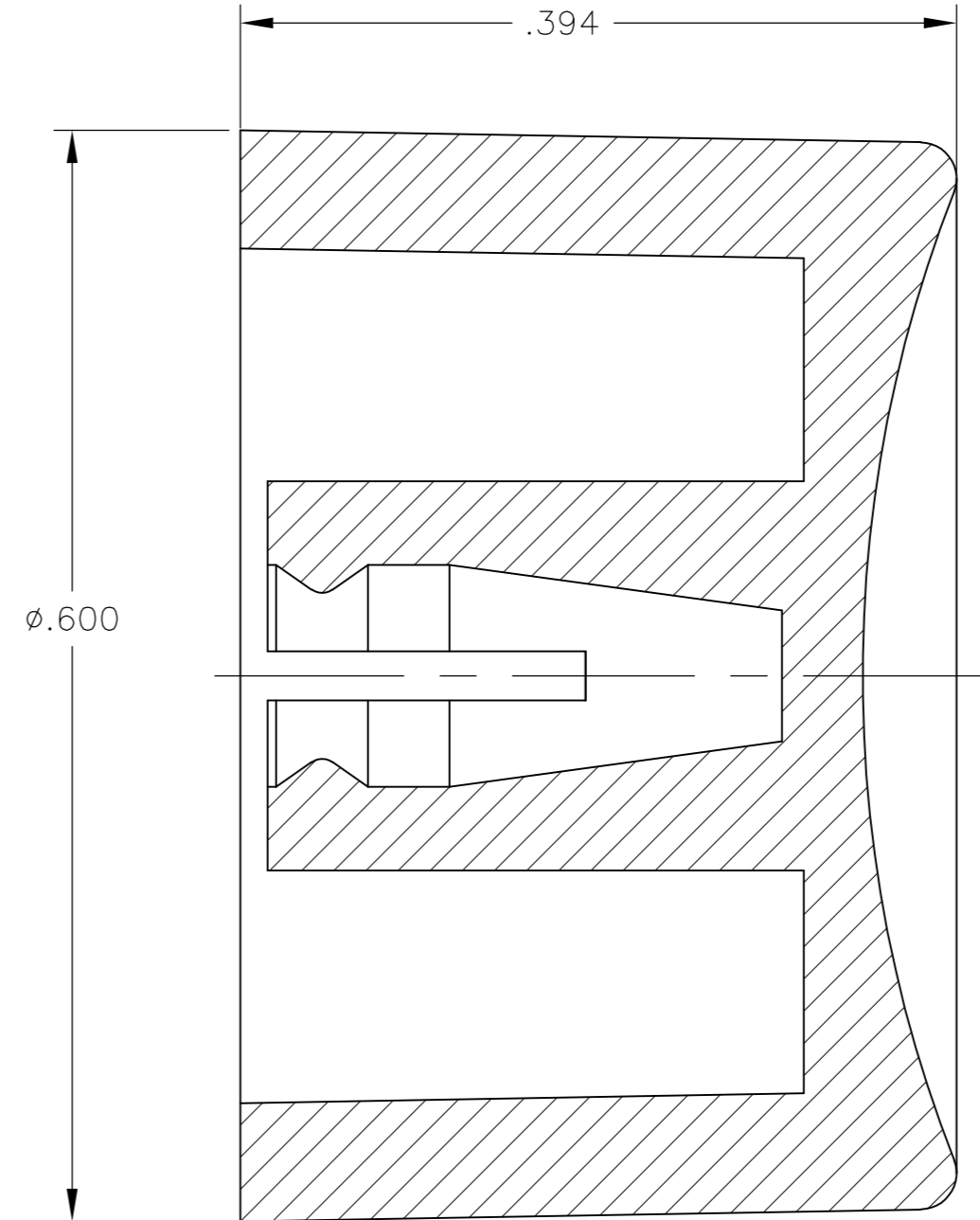
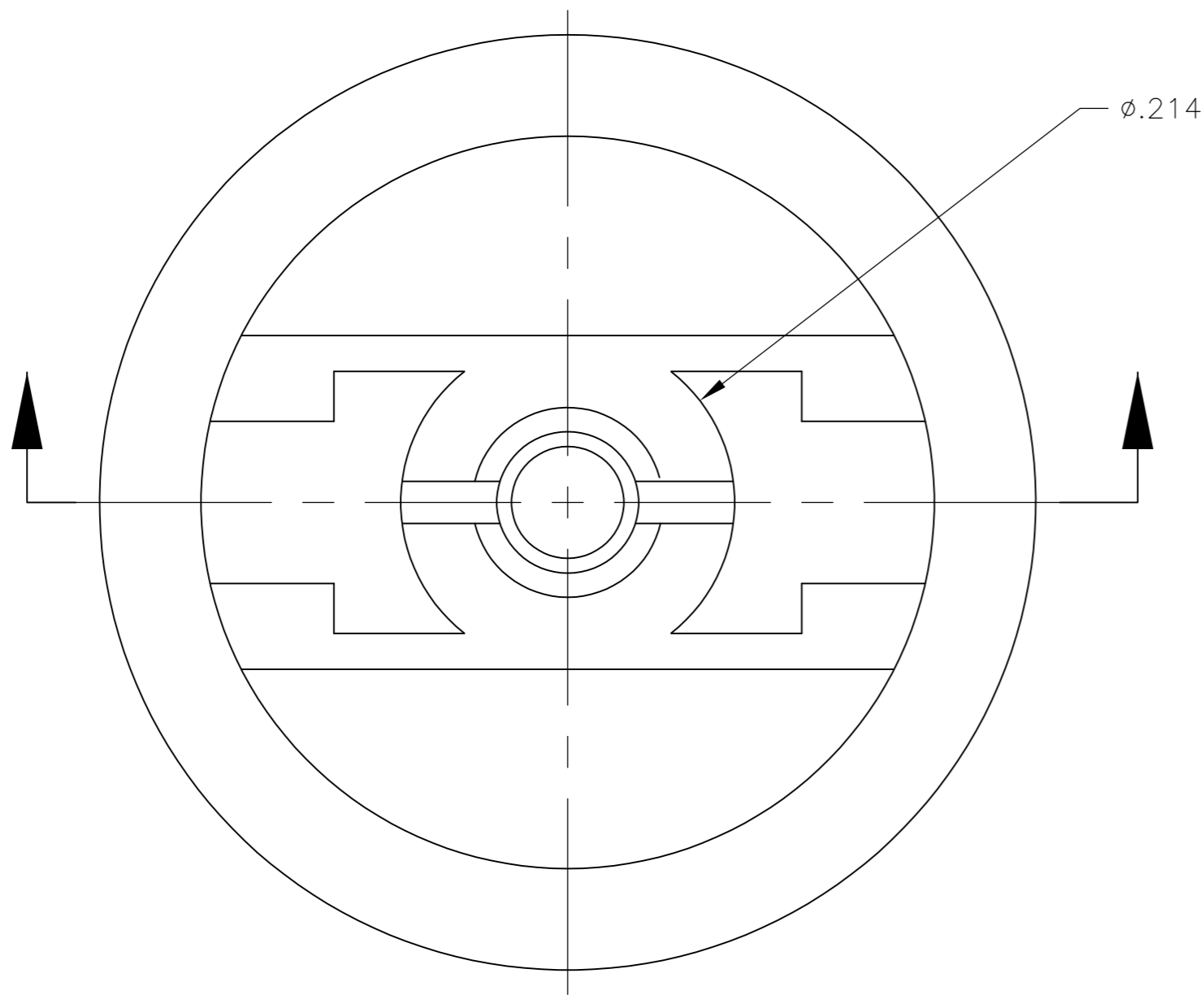

- 1 MATERIAL SHALL COMPLY WITH EU DIRECTIVE 2002/95/EC OF 20JAN2003 (ROHS)
- 2 CAP FOR USE WITH GREEN SERIES PUSHBUTTON SWITCHES AS SHOWN ON DRAWINGS 4-1437567-3 AND 2-1437567-9

|        |                  |                |
|--------|------------------|----------------|
| WHITE  | C23904           | 1825069-7      |
| BLUE   | C23604           | 1825069-6      |
| GREEN  | C23504           | 1825069-5      |
| YELLOW | C23404           | 1825069-4      |
| ORANGE | C23304           | 1825069-3      |
| RED    | C23204           | 1825069-2      |
| BLACK  | C23004           | 1825069-1      |
| COLOR  | ALCO PART NUMBER | TE PART NUMBER |

|  |   |          |          |           |                  |       |           |            |               |   |   |       |   |      |       |   |   |        |   |    |              |      |
|--|---|----------|----------|-----------|------------------|-------|-----------|------------|---------------|---|---|-------|---|------|-------|---|---|--------|---|----|--------------|------|
| THIS DRAWING IS A CONTROLLED DOCUMENT.   |   | DWN      | M.BINNER | 30NOV04   |                  |       |           |            |               |   |   |       |   |      |       |   |   |        |   |    |              |      |
| DIMENSIONS: INCHES   |   | CHK      | M.ZITTO  | 30NOV04   |                  |       |           |            |               |   |   |       |   |      |       |   |   |        |   |    |              |      |
| TOLERANCES UNLESS OTHERWISE SPECIFIED:   |   | APVD     | M.ZITTO  | 30NOV04   |                  |       |           |            |               |   |   |       |   |      |       |   |   |        |   |    |              |      |
| <table border="1"> <tr><td>0 PLC</td><td>±</td><td>-</td></tr> <tr><td>1 PLC</td><td>±</td><td>-</td></tr> <tr><td>2 PLC</td><td>±</td><td>-</td></tr> <tr><td>3 PLC</td><td>±</td><td>.003</td></tr> <tr><td>4 PLC</td><td>±</td><td>-</td></tr> <tr><td>ANGLES</td><td>±</td><td>1°</td></tr> </table> |   | 0 PLC    | ±        | -         |                  | 1 PLC | ±         | -          | 2 PLC         | ± | - | 3 PLC | ± | .003 | 4 PLC | ± | - | ANGLES | ± | 1° | PRODUCT SPEC | NAME |
| 0 PLC  | ± | -        |          |           |                  |       |           |            |               |   |   |       |   |      |       |   |   |        |   |    |              |      |
| 1 PLC  | ± | -        |          |           |                  |       |           |            |               |   |   |       |   |      |       |   |   |        |   |    |              |      |
| 2 PLC  | ± | -        |          |           |                  |       |           |            |               |   |   |       |   |      |       |   |   |        |   |    |              |      |
| 3 PLC  | ± | .003     |          |           |                  |       |           |            |               |   |   |       |   |      |       |   |   |        |   |    |              |      |
| 4 PLC  | ± | -        |          |           |                  |       |           |            |               |   |   |       |   |      |       |   |   |        |   |    |              |      |
| ANGLES   | ± | 1°       |          |           |                  |       |           |            |               |   |   |       |   |      |       |   |   |        |   |    |              |      |
| MATERIAL: POLYAMIDE  |   | FINISH   | -        |           | APPLICATION SPEC | SIZE  | CAGE CODE | DRAWING NO | RESTRICTED TO |   |   |       |   |      |       |   |   |        |   |    |              |      |
| -  |   | WEIGHT   | -        |           | SCALE            | 10:1  | SHEET     | 1 of 1     | REV           |   |   |       |   |      |       |   |   |        |   |    |              |      |
| CUSTOMER DRAWING   |   | A2 00779 |          | C=1825069 |                  | -     |           |            |               |   |   |       |   |      |       |   |   |        |   |    |              |      |