



RM/RC-W machined contact SM/SC-W stamped contacts

Size 20 contacts for UTOW connectors

Description

Size 20 contacts with a .040" (1.0mm) pin diameter are two piece crimp snap-in contacts in pin and socket version available in:

- Solid machined version
- Stamped and formed version
- Solid machined dip solder contacts
 - 50A7
 - 5016

And designed for heavy duty top performance requirements. These contacts consist of a crimp/solder body made of high conductive copper alloy, and a stainless steel retaining spring featuring retention in the housing cavity and a closed entry socket to prevent probe damage. Crimp contacts accommodate AWG20 through AWG26 wire and the crimp barrels.

All contacts have to be ordered separately

Features and benefits

- Made from high conductive copper alloy with gold plate finish.
- Two piece construction with dual purpose spring which serves for contact retention and protects the body against damage.
- Stamped and formed contacts packaging
 - On reel: 3000 pcs
 - In bulk packing: 100 pcs in plastic bag
- Solid machined crimp and dip solder contacts packaging
 - 50 pcs in plastic box

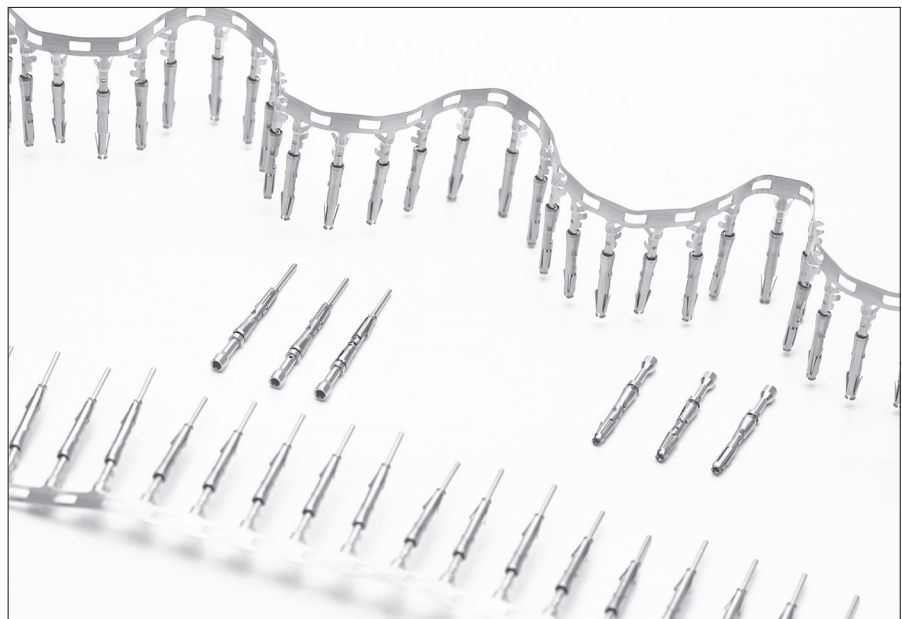

Performance characteristics

	Machined	Stamped and Formed
Current rating:	7,5 Amps	5 Amps
Contact resistance:	≤ 6 mΩ	≤ 15 mΩ
Dielectric withstanding voltage:	1500 V Rms min	
Contact retention in body:	90 N max.	
Contact engagement force:	5 N max.	
Contact separation force:	2 N min.	
Plating:	0.40 μ gold over nickel	0.75 μ gold over nickel

Construction

Contact body: High conductive copper alloy.
Outer spring: Stainless steel

Connector accommodation

Any size 20 contacts for UTOW connectors can be used in any contact position.

How to order

Contact type		Part number	AWG	Section mm ²	Insulation diameter	Tooling		
Machined crimp	Pin	RM24W3K	26 – 24	0.13 – 0.25	0.89 – 1.58	MH860 + positionner MH86301		
		RM20W3K	22 – 20	0.35 – 0.50	1.17 – 2.08			
		RM18W3K	20 - 18	0.50 - 1.00	1.20 - 2.10			
	Socket	RC24W3K	26 – 24	0.13 – 0.25	0.89 – 1.58			
		RC20W3K	22 – 20	0.35 – 0.50	1.17 – 2.08			
		RC18W3K	20 - 18	0.50 - 1.00	1.20 - 2.10			
Stamped & formed crimp	Pin	SM24W3S26 SM24WL3S26	26 – 24	0.13 – 0.25	0.89 – 1.58	Y16SCM3 or Y14MTV		
		SM20W3S26 SM20WL3S26	22 – 20	0.35 – 0.50	1.17 – 2.08			
		SC24W3S25 SC24WL3S25	26 – 24	0.13 – 0.25	0.89 – 1.58			
	Socket	SC20W3S25 SC20WL3S25	22 - 20	0.35 – 0.50	1.17 – 2.08			
		Machined Dip solder		Pin	50A7		RMW50AK7	For solder tail details see next page.
				Pin	5016		RMW5016K	
		Socket	50A7	RCW50A7K				
		Socket	5016	RCW5016K				

RM/RC-W Machined Contacts



Nominal length (dim G) of dipsolder contacts out of connector (contacts to be ordered separately)

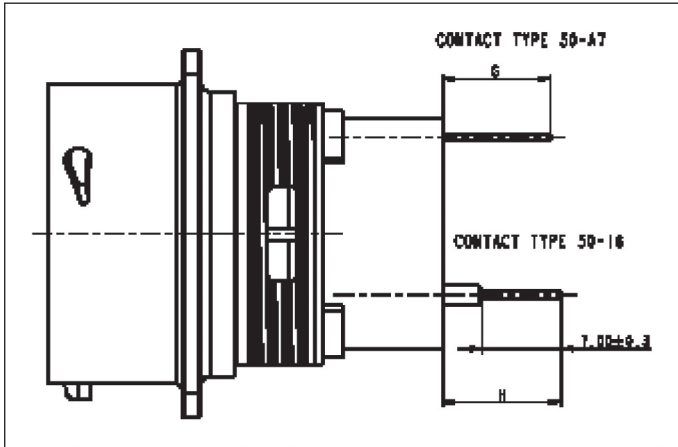

UT0W0 wall mounting receptacle connectors

Connector size	Pin contact	Socket contact		
	RMW50A7K	RMW5016K	RCW50A7K	RCW5016K
10	9.43	10.33	9.85	10.50
12				
14				
16				
18				
20	9.24	10.32	7.65	8.31
22				
24				

UT0W7 jam nut receptacle connectors

Connector size	Pin contact	Socket contact		
	RMW50A7K	RMW5016K	RCW50A7K	RCW5016K
10	9.51	10.41	2.4	3.04
12				
14				
16				
18				
20	5	6	-	-
22				
24				

For recommended PC-Board hole lay out: Consult factory