

MBN52832

Bluetooth® Low Energy Module



MBN52832 is a Bluetooth Low Energy/NFC module. It enables ultra-low power connectivity for data communication. The module integrates Nordic Bluetooth Low Energy IC, RF front end, and crystal into a very small form factor. The built-in ARM Cortex M4 core with 64KB RAM and 512KB flash provides a high performance engine and rich interfaces for variety of IoT applications such as sensor network, device control, etc. This RF certified module can significantly reduce the system designer's burden and help to reduce the time-to-market.

It is an ideal solution for smart device, medical and healthcare, and M2M applications.

Module Features

- ❖ Bluetooth® v5, ANT, NFC Tag
- ❖ Nordic nRF52832 Bluetooth Smart®
- ❖ Built-in ARM Cortex M4 core with 64KB RAM and 512KB flash
- ❖ Dimension 7.4 x 7.0 x 0.9 mm
- ❖ Packaging: LGA
- ❖ Bluetooth/ANT Antenna Configuration:
 - ❖ On-board PCB antenna
 - ❖ Supports external antenna from pin pad
- ❖ Maximum transmit power: +4.0dBm (@ antenna port LDO Mode)
- ❖ Receive sensitivity: -93dBm @ 1Mbps (LDO Mode)
- ❖ Power consumption
 - ❖ TX 7mA @ 3.5dBm (DCDC Mode)
 - ❖ RX 6mA (DCDC Mode)
- ❖ Host interface: UART, SPI
- ❖ Other interfaces: 20 GPIO, 5 ADC, UART, SPI (master and slave), I2C, PWM and Debug SWD
- ❖ Operating temperature range: -40 °C to 85 °C
- ❖ RoHS compliant
- ❖ MSL Level 3 in accordance with JEDEC J-STD-020
- ❖ Regulatory certificates: FCC, IC, ETSI, TELEC

Applications

- ❖ Home automation
- ❖ Proximity Services
- ❖ Building automation
- ❖ Medical/Healthcare
- ❖ Beacon

Module Block Diagram

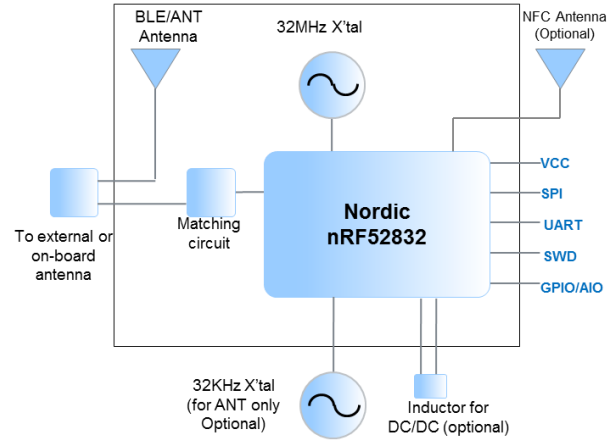

Development Kit



The MBN52832 Development Kit is designed to facilitate application development using the Nordic nRF52 SDK. The EVB supports the same J-Link USB-SWD and USB-UART interfaces as those provided by the nRF52 DK to ease the debugging and development process.

Ordering Information

Model Number	Product	Ordering Part Number
MBN52832	Engineering Sample	WSM-BL241-ADA-008S
MBN52832	Production Module (Coming soon)	WSM-BL241-ADA-008
MBN52832DK	Development Kit	WSM-BL241-ADA-008DK