

### Innovative and Powerful Features!

- ◆ For global use with single- and two phase wide-range input 100/230–500 VAC
- ◆ Rugged metal case for harsh industrial environments
- ◆ Industrial operating temperature range:  $-25^{\circ}\text{C}$  to  $+70^{\circ}\text{C}$
- ◆ Power OK signal
- ◆ Remote On/Off
- ◆ Shock and vibration-proof
- ◆ Indefinite short circuit, overvoltage and overtemperature protection
- ◆ Redundancy module
- ◆ Buffer module for power backup
- ◆ Battery controller module
- ◆ 3-year product warranty



The successful TSP series of high performance DIN-rail mount power supplies has been expanded with 3 additional models which features an ultrawide input range of 85-132/187-550VAC. With these input voltages the power supplies can be used in almost all single- and multi phase power networks worldwide.

A high, continuously available power reserve guarantees reliable start-up of loads with high inrush currents. Excellent electrical specifications and high immunity against electrical disturbances make these compact power supplies the best choice to power sensitive loads in industrial process control systems, machine tools or any other demanding industrial application. The power supplies comply also with IEC/EN 61204-3, the EMC standard for Industrial environment.

3 add-on modules for extra functions offer a great flexibility in system applications. A module for redundant operation with true power sharing is available. With the battery controller module the power supplies can be extended to a perfect DC-UPS system. The buffer module provides power back-up for up to 4 seconds without the need of any batteries. Easy and vibration proof installation with pluggable screw terminal block and snap-on mounting on DIN-rails.

### Models

Order Code	Output Voltage (Vnom)	*Output Current (Imax)	Output Power (Pmax)
TSP 180–124WR	24 VDC (adjustable 24 - 28 VDC)	7.5 A	180 W
TSP 360–124WR		15.0 A	360 W
TSP 600–124WR		25.0 A	600 W

\* Max. current at nominal output voltage and operating temperature up to  $40^{\circ}\text{C}$  max.

### Input Specifications

Applicable 3-phase networks	– TN, TT Systems:	500 VAC Star configuration (EN60950, UL508) 500 VAC Delta (UL508 only)
	– IT Systems:	400 VAC Delta (IEC-62103) 230 VAC Delta (IEC-60950) 500 VAC (UL508)
Input voltage ranges		85–132 VAC/187–550 VAC 50/60 Hz range selectable by selector switch 187–264 VAC/323–550 VAC autoranges
Harmonic limits		EN 61000-3-2, Class A (for limited output power)
Holdup time		20 ms min. (full load 230 – 500 VAC)
Inrush current		115 VAC      230 VAC
	TSP 180-124VWR	t.b.a      < 23 A
	TSP 360-124VWR	t.b.a      < 46 A
	TSP 600-124VWR	t.b.a      < 50 A
Efficiency		88 % typ.

### Output Specifications

Output voltage adjustable range		24–28 VDC
Regulation	– Input variation	0.5 % max.
	– Load variation (10–100 %)	0.5 % max.
	– Load variation (10–100 %) parallel mode	2.0%
Ripple and noise (20MHz bandwidth)		100 mV pk-pk typ. (150 mV pk-pk max. at I <sub>max</sub> )
Electronic short circuit protection		current limitation at 125 % of I <sub>max</sub> . constant current, automatic recovery
Output overvoltage protection		34 V
Overload protection		electronic overload protection
Overtemperature protection		switch off at overtemperature, automatic restart
Status indicator		dual colour LED (green: DC OK, red: DC off)
Power OK signal	– trigger threshold	18 – 22 V
	– relay output	DC OK = contact closed (rated: 30 VDC/1.0 A)
Max. capacitive load		unlimited

### General Specifications

Operating temperature range		–25°C to +70°C max. (for derating see graph A on page 3)
Cooling		convection cooling, no internal fan
Storage temperature		–25°C to +85°C
Humidity (non condensing)		95 % rel. H max.
Pollution degree		2
Temperature coefficient		0.02 %/K
Reliability, calculated MTBF at +25°C acc. to IEC 61709		>350'000 heures in accordance to IEC 61709
Remote On/Off		by ext. contact. DC on: -S contact open DC off: -S connected via 1 Kohm to -Vout
Isolation		according to IEC/EN 60950-1, UL 60950-1
Safety standards	– Information technology equipment	IEC/EN 60950-1, UL 60950-1, CSA-C22.2 No. 60950-1-03, CSA-C22.2 No. 107
	– Electrical equipment of machines	EN 60204
	– Electronic equipment for power installation	EN 50178
	– Safety transformers for SMPS	EN 61558-2-16

All specifications valid at nominal input voltage, full load and +25°C after warm-up time unless otherwise stated.

**General Specifications**

Safety approvals and certifications	– CB scheme (for IEC 60950-1)	<a href="http://www.tracopower.com/products/tsp-wr-cb.pdf">www.tracopower.com/products/tsp-wr-cb.pdf</a> for UL 60950-1 (file no. 219759) CSA-22.2 No. 60950-1-03, CSA C22.2 No. 107.1-01 <a href="http://www.tracopower.com/products/tsp-wr-csa.pdf">www.tracopower.com/products/tsp-wr-csa.pdf</a> for IEC/EN 60950-1, EN 60204, EN 61558-2-4 <a href="http://www.tracopower.com/products/tsp-wr-gs.pdf">www.tracopower.com/products/tsp-wr-gs.pdf</a> <a href="http://www.tracopower.com/products/tsp-wr-siq.pdf">www.tracopower.com/products/tsp-wr-siq.pdf</a>
	– CSA certificate	
	– GS certificate	
	– SIQ certificate (IEC/EN 60950-1)	
Safety class		Degree of electrical protection I (IEC 536)
Case protection		IP 20 (IEC 529)
Electromagnetic compatibility (EMC), Emissions	– Conducted RI suppression on input – Radiated RI suppression	IEC/EN 61000-6-3, IEC/EN 61204-3 EN 55011 class B, EN 55022 class B, EN 55011 class B, EN 55022 class B,
Electromagnetic compatibility (EMC), Immunity	– Electrostatic discharge (ESD) – Radiated RF field immunity – Electrical fast transient / burst immunity – Surge immunity – Immunity to conducted RF disturbances – Power frequency field immunity – Voltage dips	IEC/EN 61000-6-2, IEC/EN 61204-3 IEC/EN 61000-4-2 4 kV / 8 kV IEC/EN 61000-4-3 10 V / m IEC/EN 61000-4-4 2 kV IEC/EN 61000-4-5 1 kV / 2 kV IEC/EN 61000-4-6 10 V IEC/EN 61000-4-8 30 A / m IEC/EN 61000-4-11
Environment	– Vibration acc. IEC 60068-2-6; – Shock acc. IEC 60068-2-27	3 axis, sine sweep, 10-55 Hz, 1g, 1oct/min 3 axis, 15 g half sine, 11 ms
Enclosure material		aluminium (chassis) / zinc plated steel (cover)
Mounting	– DIN-rail mounting  – Wall mounting (option)	for DIN-rails as per EN 50022-35x15/7.5 (snap-on with self-locking spring) with <b>wall mounting bracket</b> - see page 10
Connection		detachable screw terminals (plugs included) 2 terminals per output

**Output Power Derating**

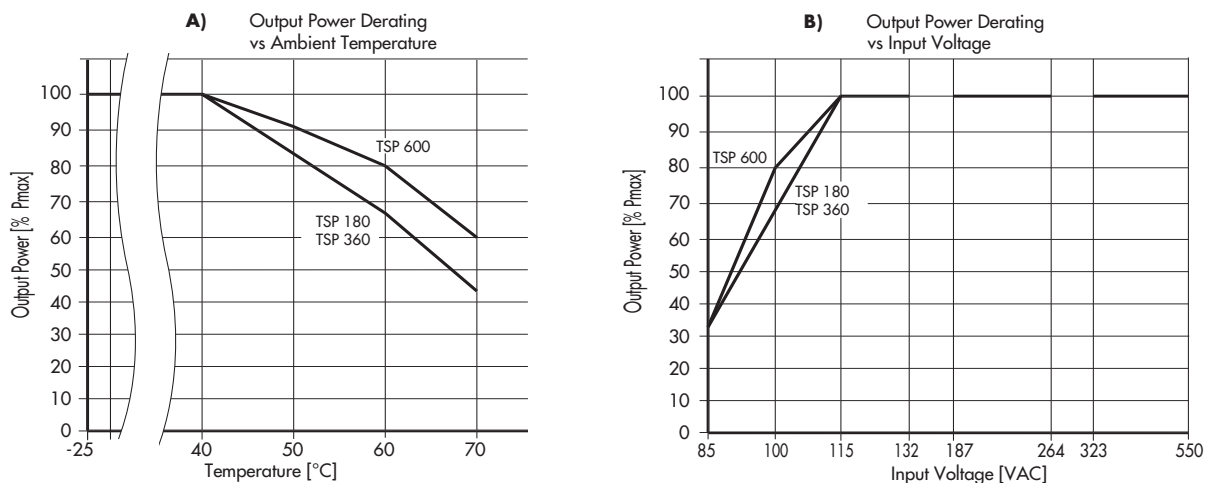

All specifications valid at nominal input voltage, full load and +25°C after warm-up time unless otherwise stated.

**TSP-REM360 Redundancy Module**

With this module and two power supplies of the TSP-WR series (of same type) a highly reliable, true redundant power system can be configured without any additional components. This module enforces equivalent sharing of the output current by each power supply. The system is fully redundant and provides output power even if one power supply has completely failed e.g. by short circuit on the output. In the event of either power supply failing or being disconnected, the second unit will automatically supply the full current to the load. The redundancy of the system is monitored and if lost, indicated by an alarm output. The inputs are hot swappable and can be loaded up to 15A each.



**Models**

Order Code (includes terminal plugs)	Input	Max Power per Input	Output Voltage adjust.	Output Power max.
<b>TSP-REM360</b>	2 x 24 VDC	2 x 360 W	<b>24 VDC</b> (24 - 27 VDC)	<b>360 W</b>
<b>TSP-REM600</b>	2 x Control input	2 x 600 W		<b>600 W</b>

**Function Diagram**

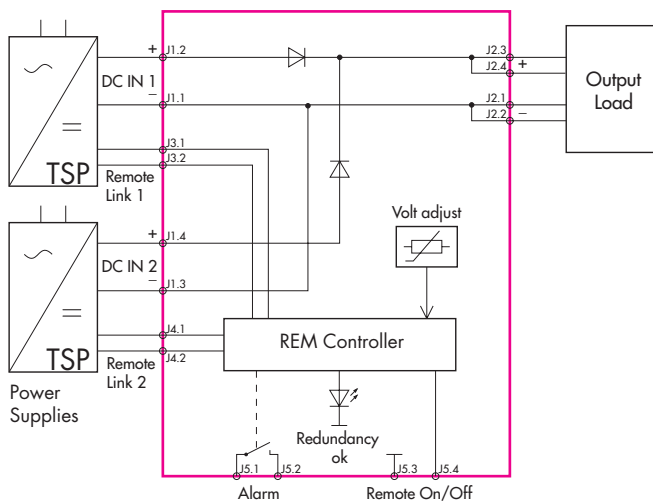

**Connector Positions**

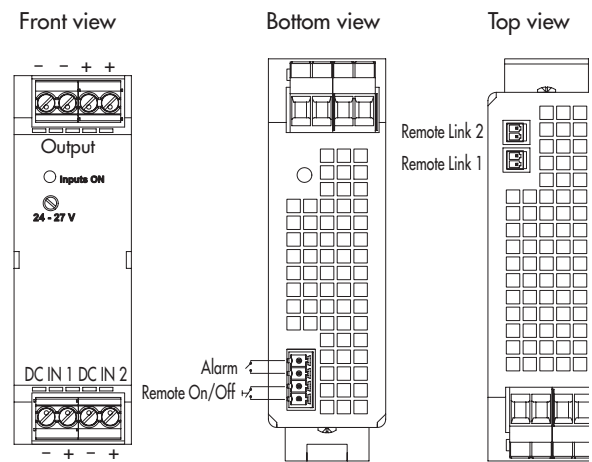

**Specifications**

Operating temperature	-25°C to +70°C max. derating above +40°C :1.5 %/K
Electromagnetic compatibility	in correspondence to connected units (no internal switching device)
Redundancy OK signal (Alarm)	trigger threshold at 18–22VDC, contact open if both inputs failed
Dimensions	see page 8
Remote link cable (0.5m)	2 cables included (order code TSPJC) <a href="http://www.tracopower.com/products/tsp-rc-cable.pdf">www.tracopower.com/products/tsp-rc-cable.pdf</a>
Remote On/Off	by ext. contact: contact open = On, contact closed = Off
Installation instructions	<a href="http://www.tracopower.com/products/tsp-rem_inst.pdf">www.tracopower.com/products/tsp-rem_inst.pdf</a>

**TSP-BFM24 Buffer Module**

The TSP-BFM24 buffer module will hold the output voltage of a 24 VDC power supply after brown outs or voltage dips of ten 50Hz cycles at full load. During this buffer period no deterioration of the 24 VDC output voltage will occur. For many applications this buffer module is an ideal and cost effective alternative to a battery based backup system. The buffer module consists of a large bank of capacitors. When the power supply is switched on, the buffer capacitors will be charged. This will take approximately 30 seconds and an opto-coupler signal indicates the "READY" condition. When a power fail occurs, the capacitor bank is discharged, maintaining the output of the buffer module at its nominal voltage. This condition is indicated by an "POWER FAIL" signal. The hold up time is typically 200 ms at 25 A and 4 seconds typically at 1,2A. After 4 seconds the buffer device will switch off the output voltage. The operation modes of the module are indicated by a LED on the front panel also. The big advantage of this buffer solution is, that it is fully maintenance free and its storage capability does not deteriorate over the live time of the product.



**Models**

Order Code (includes terminal plugs)	Operating Voltage Range	Buffer Time	Output Power max.
TSP-BFM24	24...28VDC	200ms typ. @ 25A max. 4.0 s max. @ 1.2 A	600 W

Function Diagram

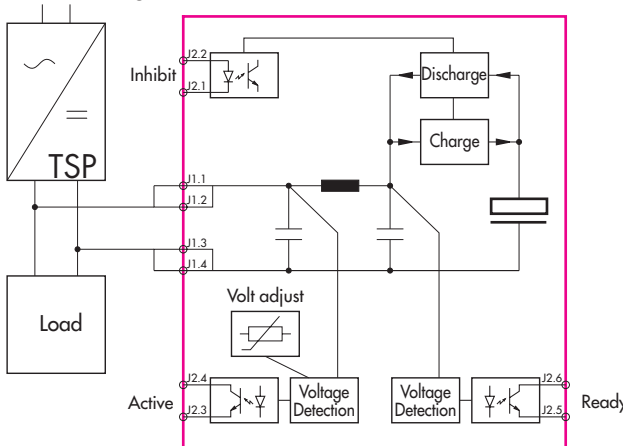

Connector Positions

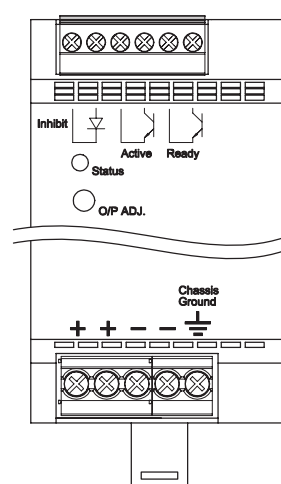

**Specifications**

Operating temperature	-25°C to +70°C max. derating above +40°C : 1.5 %/K
Electromagnetic compatibility	in correspondence to connected units (no internal switching device)
Buffer voltage	adjustable, >1 V below input voltage, min. 22 VDC
Charging	0.6 A max./30 s max.
Status signals	Buffer Active , Buffer Ready (optocoupler output) and dual colour LED for status indication
Inhibit	optocoupler input: 35 V max. < 5mA
Dimensions	see page 8
Installation instructions	<a href="http://www.tracopower.com/products/tsp-bfm_inst.pdf">www.tracopower.com/products/tsp-bfm_inst.pdf</a>

**TSP-BCM24 Battery Controller Module**

This module provides a professional battery management system to charge and monitor an external lead-acid battery. Together with a power supply of the TSP series, a perfect DC-UPS system can be configured. The connected battery will be charged and held in charged mode by the power supply. In the event of a mains power failure the battery will supply the output power until the battery is discharged. As a consequence, the output voltage of the system is equivalent to the battery voltage. To avoid overcharging the battery, an external temperature sensor adjusts the battery voltage automatically to the required end of charge voltage. This can extend the battery life.

The battery is protected against deep discharge. Mains power and battery status are monitored regularly and failures indicated by corresponding LED's and alarm outputs. The module also provides an external On/Off input to switch-off both, power supply and battery.



TSP-TS battery temperature sensor (10 kOhm NTC with 2m cable) included

**Models**

Order code (includes terminal plugs)	Inputs	Input Power max	Output Voltage nom.	*Output Power max.
<b>TSP-BCM24</b>	24 VDC Power Supply	360 W	<b>24 VDC</b>	<b>360 W</b>
<b>TSP-BCM24A</b>	and 24 VDC Battery	600 W		<b>600 W</b>

\*reduce max. output current by battery charging current

**Function Diagram**

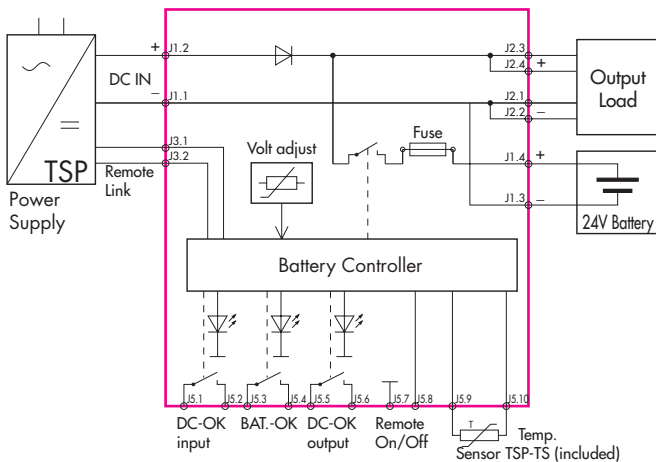

**Connector Positions**

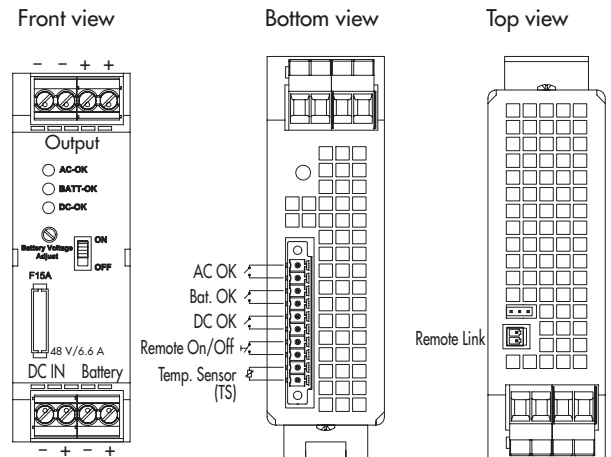

**Specifications**

Operating temperature	-25°C to +70°C max. derating above +40°C 1.5 %/K
Electromagnetic compatibility	in correspondence to connected units (no internal switching device)
Battery protection	over voltage, deep discharge, short circuit- and revers connection (built-in fuse)
Status signals	DC-OK input, DC-OK output, BAT OK all relay contact closed at status OK
Rating per relay contact	30 VDC/1.0 A max.
Dimensions	see page 8
Remote link cable (0.5m)	1 cable included (order code TSP-JC) <a href="http://www.tracopower.com/products/tsp-rc-cable.pdf">www.tracopower.com/products/tsp-rc-cable.pdf</a>
Remote On/Off	by ext. contact: contact open = On, contact closed = Off
Installation instructions	<a href="http://www.tracopower.com/products/tsp-bcm_inst.pdf">www.tracopower.com/products/tsp-bcm_inst.pdf</a>



**TSP-BAT Battery Pack**

TSP battery packs are designed to build, in connection with the TSP-BCM battery controller module, a complete DC-UPS system. The entire range utilizes 12V maintenance free VRLA (valve regulated lead acid) batteries made by PANASONIC. These are not spillable lead gel type batteries. Two 12V batteries are connected in series and assembled into a stainless steel enclosure, with integrated connector and connection cable.



**Models**

Order Code (includes mating connectors)	Nominal Voltage	Charge Current max.	Nominal Capacity (at 25°C, 77°F)
TSP-BAT24-034	24 VDC	0.80 A	3.4 Ah
TSP-BAT24-072		1.75 A	7.2 Ah
TSP-BAT24-120		3.00 A	12.0 Ah

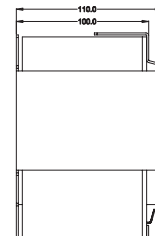
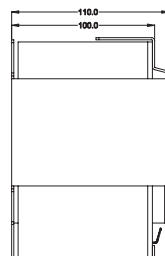
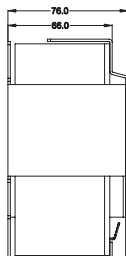
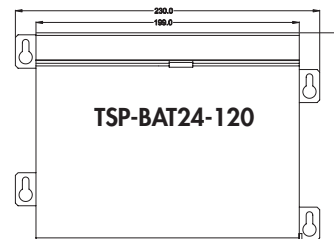
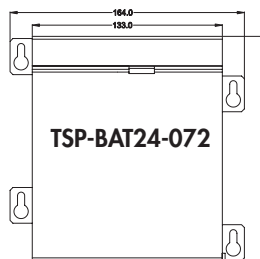
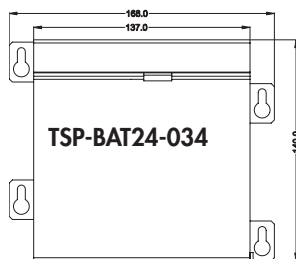

Detailed drawings in process

**Specifications**

Temperature ranges (max)	<ul style="list-style-type: none"> <li>- during discharge</li> <li>- when charging / charged</li> <li>- storage</li> </ul>	<ul style="list-style-type: none"> <li>-15°C to +50°C max.</li> <li>0°C to +40°C max.</li> <li>-15°C to +40°C max.</li> </ul>
Battery lifetime		3-5 years see general battery information for details: <a href="http://www.tracopower.com/products/tsp-panas_gen.pdf">www.tracopower.com/products/tsp-panas_gen.pdf</a>
Remote link cable (0.5m)		1 cable included (order code TSPJC) <a href="http://www.tracopower.com/products/tsp-rc-cable.pdf">www.tracopower.com/products/tsp-rc-cable.pdf</a>
Weight	TSP-BAT24-034 TSP-BAT24-072 TSP-BAT24-120	3.2 kg (7.1 lb) 5.8 kg (12.9 lb) 9.0 kg (20.0 lb)
Battery datasheets	TSP-BAT24-034 TSP-BAT24-072 TSP-BAT24-120	<a href="http://www.tracopower.com/products/tsp-panas_034.pdf">www.tracopower.com/products/tsp-panas_034.pdf</a> <a href="http://www.tracopower.com/products/tsp-panas_072.pdf">www.tracopower.com/products/tsp-panas_072.pdf</a> <a href="http://www.tracopower.com/products/tsp-panas_120.pdf">www.tracopower.com/products/tsp-panas_120.pdf</a>

**Case Dimensions**

**Models:**  
TSP-REM360  
TSP-BCM24

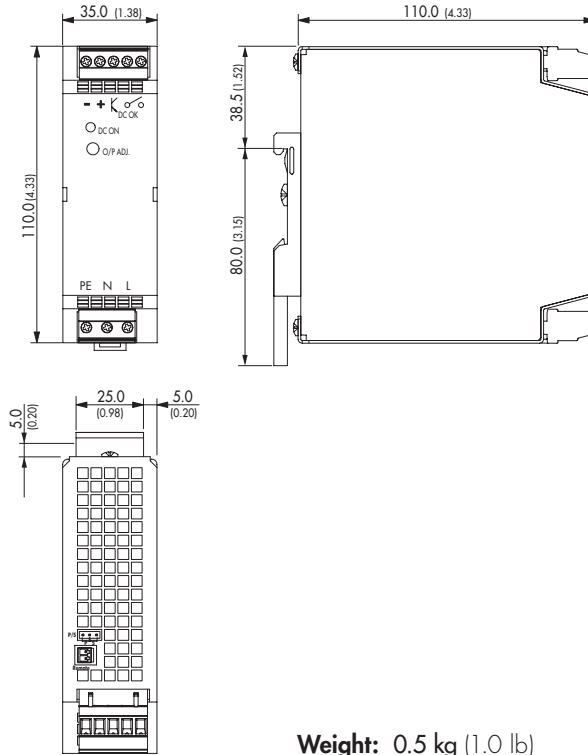

**Weight:** 0.5 kg (1.0 lb)

**Models:**  
TSP 180-124WR  
TSP-REM600  
TSP-BCM24A  
TSP-BFM24

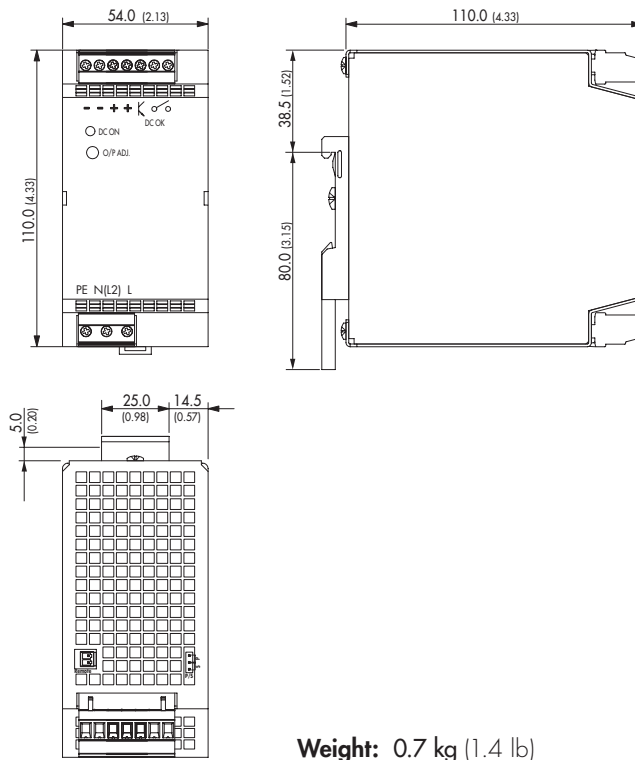

**Weight:** 0.7 kg (1.4 lb)

Dimensions in [mm], ( ) = inch  
Tolerances:  $\pm 0.5$  mm ( $\pm 0.02$ )



**Case Dimensions**

**Model:**  
TSP 360-124WR

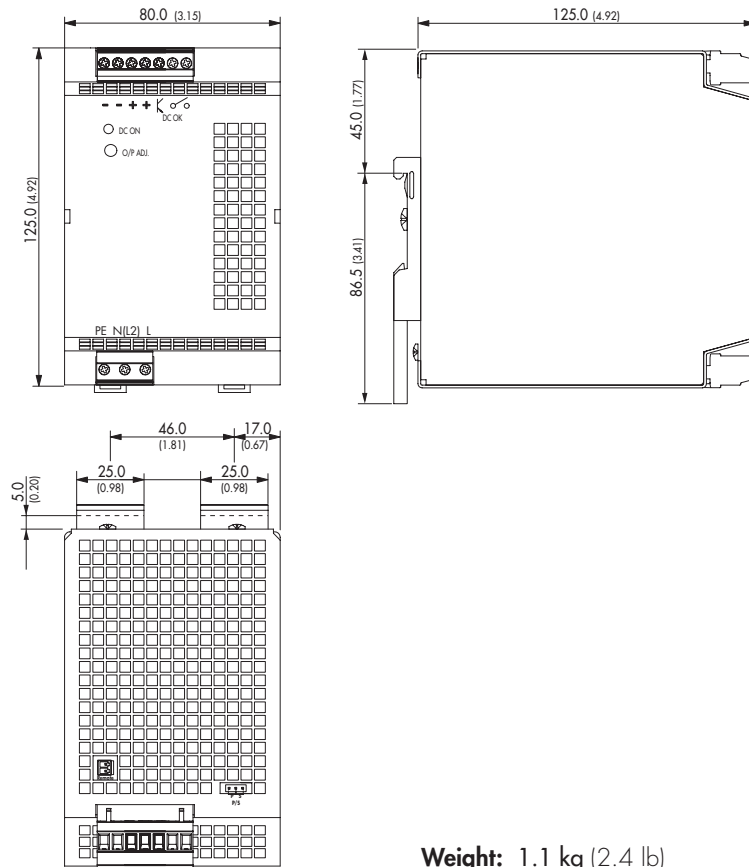

**Weight:** 1.1 kg (2.4 lb)

Dimensions in [mm], ( ) = inch  
Tolerances:  $\pm 0.5$  mm ( $\pm 0.02$ )

**Case Dimensions**

**Model:**  
TSP 600-124WR

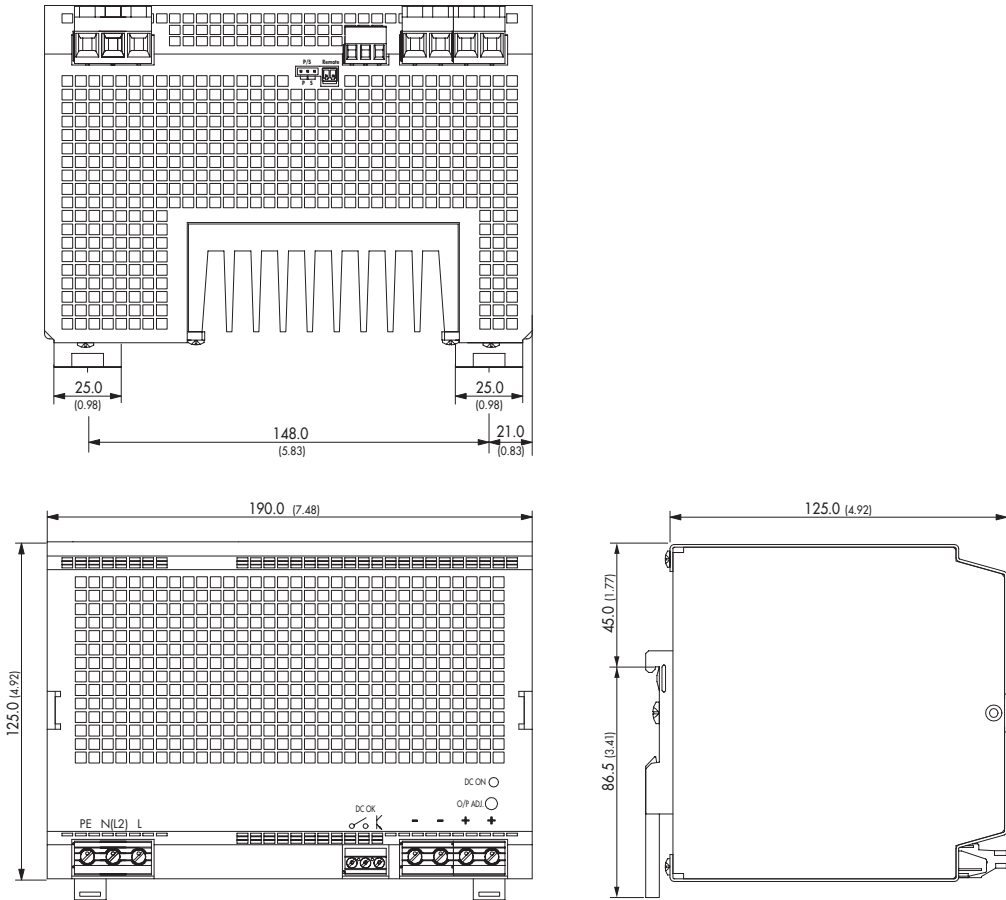

**Weight: 3.0 kg (6.0 lb)**

Dimensions in [mm], ( ) = inch  
Tolerances:  $\pm 0.5$  mm ( $\pm 0.02$ )

**TSP-WMK Wall Mounting Bracket**

Ordercode of kit	For models	Content of kit
TSP-WMK03	TSP 180-124WR, TSP-REM360, TSP-BCM24(A), TSP-BFM	1 bracket
TSP-WMK02	TSP 360-124WR, TSP 600-124WR	2 brackets

**TSP-WMK03**

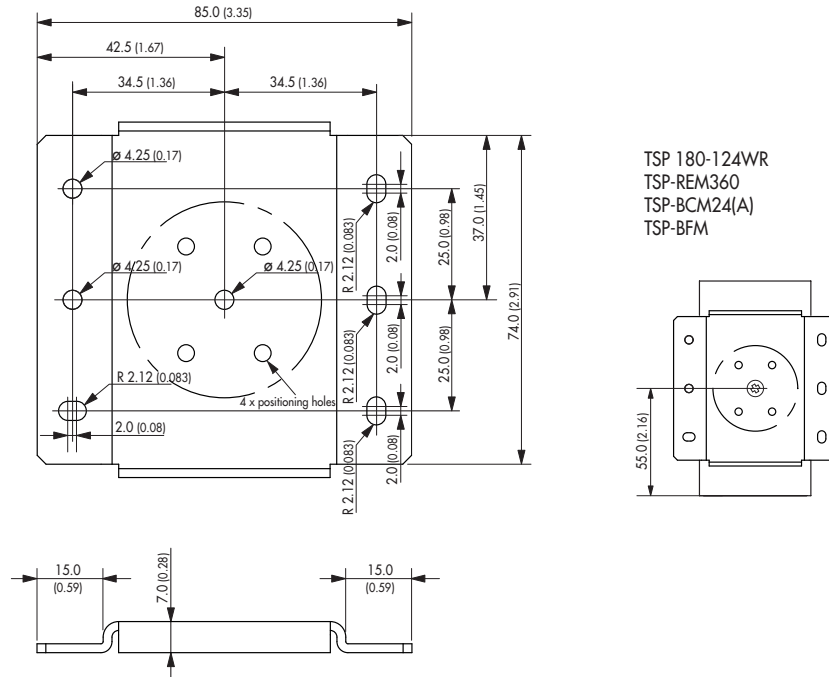

Material: 2 mm Mild Steel  
Tolerance: ±0.1mm (± 0.004)

**TSP-WMK02**

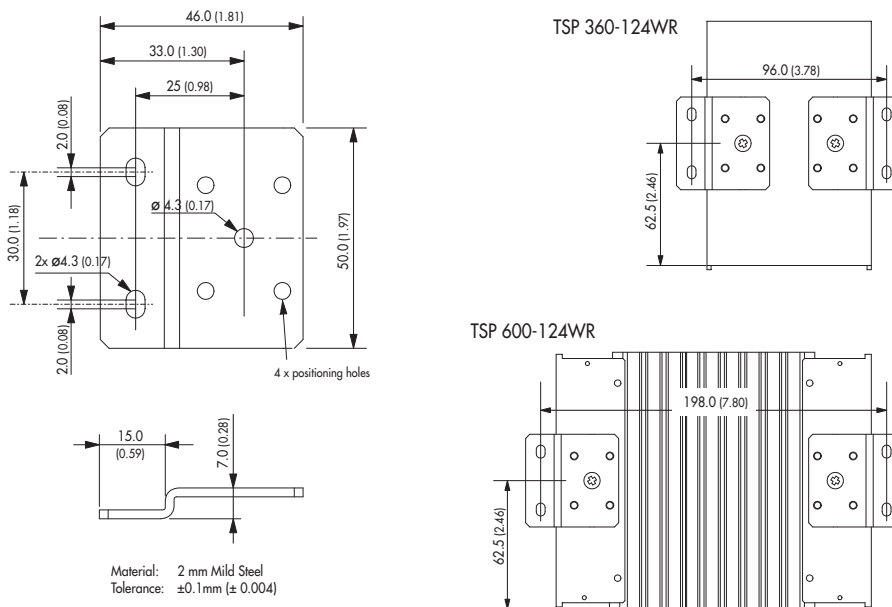

Material: 2 mm Mild Steel  
Tolerance: ±0.1mm (± 0.004)

Dimensions in [mm], ( ) = Inch  
Tolerances: ±0.5 mm (±0.02)

Specifications can be changed without notice! Make sure you are using the latest documentation, downloadable at [www.tracopower.com](http://www.tracopower.com)