

HONEYWELL
PART NUMBER
-

REV	DOCUMENT	CHANGED BY	CHECK
8	0068656	VKS 26AUG10	RS

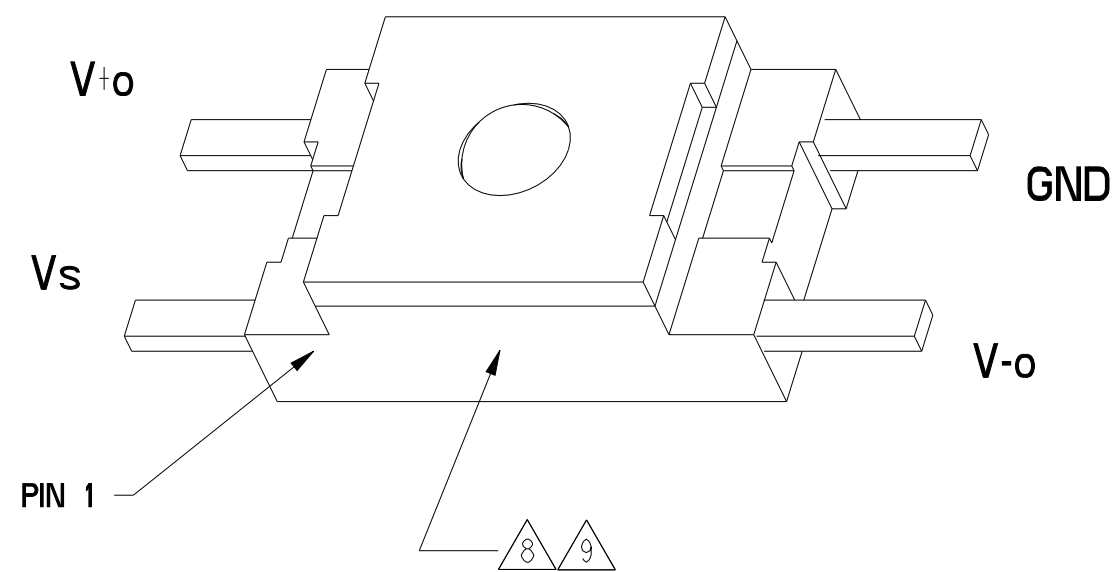

PRE-LAUNCH RELEASE

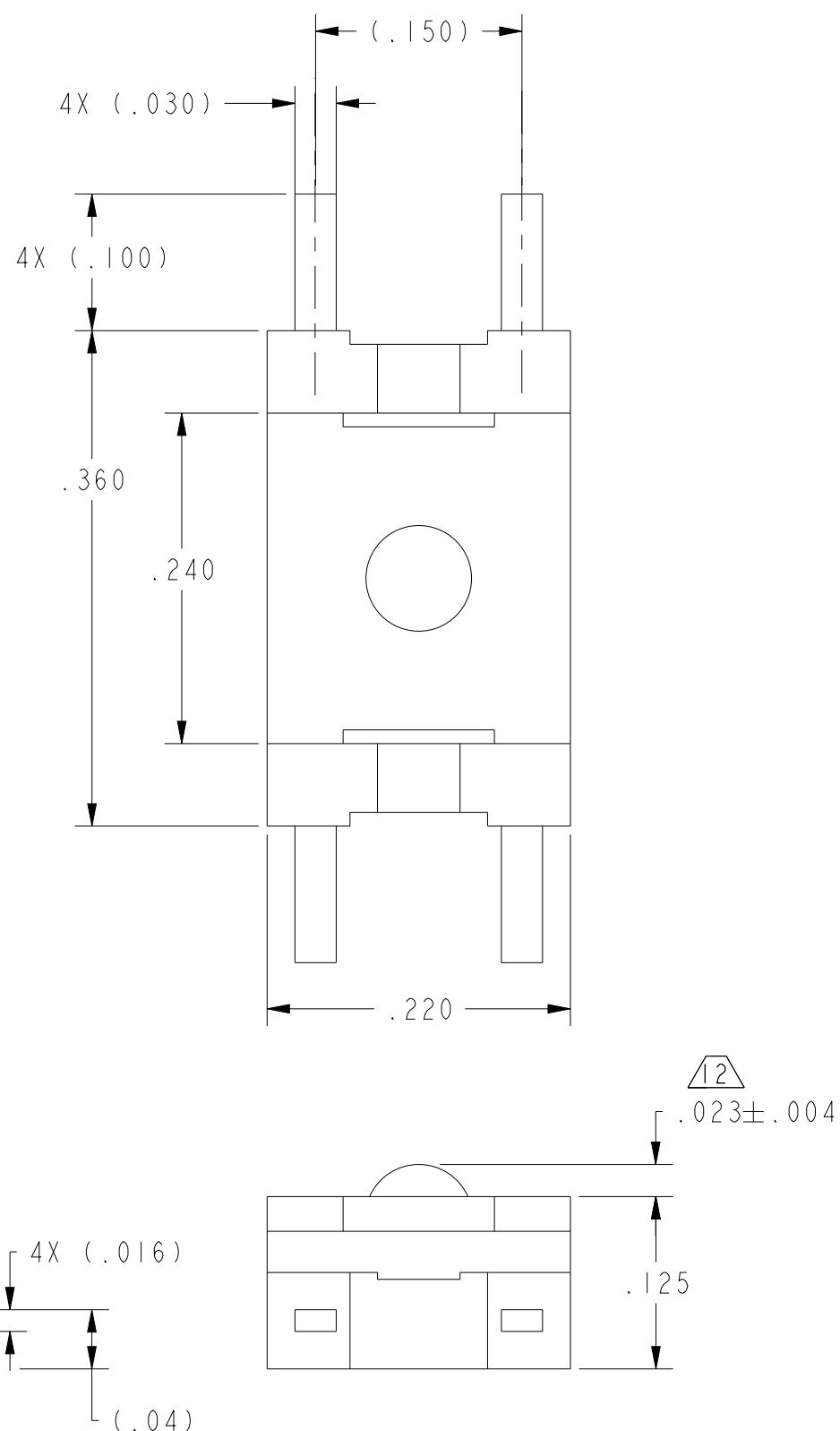

OPERATING CHARACTERISTICS				
at 5.00±.01 VDC, 25°C, UNLESS OTHERWISE NOTED				
PARAMETER	MIN	NOM	MAX	UNITS
SUPPLY VOLTAGE	3.0	5.0	6.0	V
OPERATING FORCE	0		1500	grams
NULL OFFSET	-15	0	15	mV
SPAN $\triangle 4/\triangle 5$	150	180	210	mV
SENSITIVITY	.10	.12	.14	mV/gram
	MIN	TYP	MAX	UNITS
LINEARITY (BFSL) $\triangle 6$	-1.5	±0.7	1.5	% SPAN
REPEATABILITY AT 300g		±1.5		mV
MECHANICAL HYSTERESIS		±0.5		% SPAN
NULL SHIFT $\triangle 7$ (25°C to 0°C, 25°C to 50°C)		±0.5		mV
SPAN SHIFT (25°C to 0°C) $\triangle 7$		5.5		% SPAN
SPAN SHIFT (25°C to 50°C) $\triangle 7$		-5.5		% SPAN
OVER FORCE			4500	grams
	MIN	NOM	MAX	UNITS
INPUT RESISTANCE	4.0K	5.0K	6.0K	ohms
OUTPUT RESISTANCE	4.0K	5.0K	6.0K	ohms
OPERATING TEMPERATURE (-40°C to 85°C)				
STORAGE TEMPERATURE (-40°C to 100°C)				
MCTF 20 MILLION				

CATALOGING SYSTEM

FS S 1500 N S T xx

PACKAGE STYLE
(S) SURFACE MOUNT

OPERATING FORCE RANGE
(1500) 1500 GRAMS

TEMP COMPENSATION
(C) COMPENSATED
(N) NON-COMPENSATED

LEAD STYLE
(G) GULL WING
(S) STRAIGHT

PACKING OPTION
(B) SHORT TUBE $\triangle 13$
(R) TAPE AND REEL
(T) STANDARD TUBE $\triangle 13$

SPECIAL FEATURE, BLANK = STANDARD

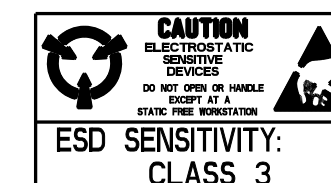

NOTES

- 1 - DEVICE IS RATIO-METRIC TO THE SUPPLY VOLTAGE
- 2 - DEVICE CAN OPERATE WITH CURRENT EXCITATION
- 3 - ALL FORCE RELATED SPECIFICATIONS ESTABLISHED BY USING DEAD WEIGHT OR COMPLIANT FORCE
- $\triangle 4$ - SPAN IS THE ALGEBRAIC DIFFERENCE BETWEEN OUTPUT AT MAXIMUM RATED OPERATING FORCE AND OUTPUT AT 0 GRAMS
- $\triangle 5$ - SPAN VERIFIED AT 1500 GRAMS
- $\triangle 6$ - MEASURED AT 1500 GRAMS
- $\triangle 7$ - TEMPERATURE ERROR IS CALCULATED WITH RESPECT TO 25°C
- $\triangle 8$ - LASER BRAND CATALOG LISTING AND DATE CODE ON THIS SURFACE. PACKING STYLE IS NOT LASER BRANDED ON PRODUCT
- $\triangle 9$ - PIN 1 IS DESIGNATED BY THE LASER-MARKED SURFACE
- 10 - MAXIMUM PEAK SMT REFLOW TEMPERATURE OF 260°C [500°F] FOR 10 SECONDS.
- 11 - MANUAL SOLDERING RECOMMENDATION: 5 SECONDS AT 315°C PER LEAD
- $\triangle 12$ - NOMINAL DIMENSION AND TOLERANCE APPLY IN BALL-UP ORIENTATION ONLY
- $\triangle 13$ - PACKING OPTION SHORT TUBE IS 5 UNITS PER TUBE STANDARD TUBE IS 100 UNITS PER TUBE

CATALOG LISTING	PRODUCT CODE	COLOR	LASER BRAND
FSS1500NSB	DXF2004	BLACK	FSI500NS
FSS1500NSR	DXF2005	BLACK	FSI500NS
FSS1500NST	DXF2006	BLACK	FSI500NS

SUGGESTED LAND PATTERN FOR LEAD STYLE "S"

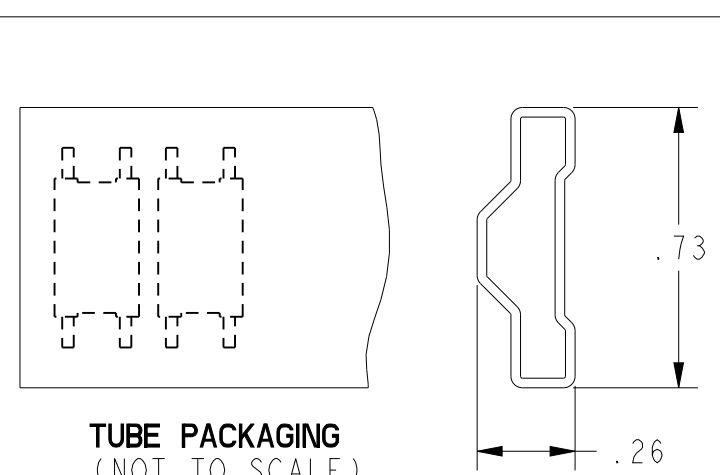
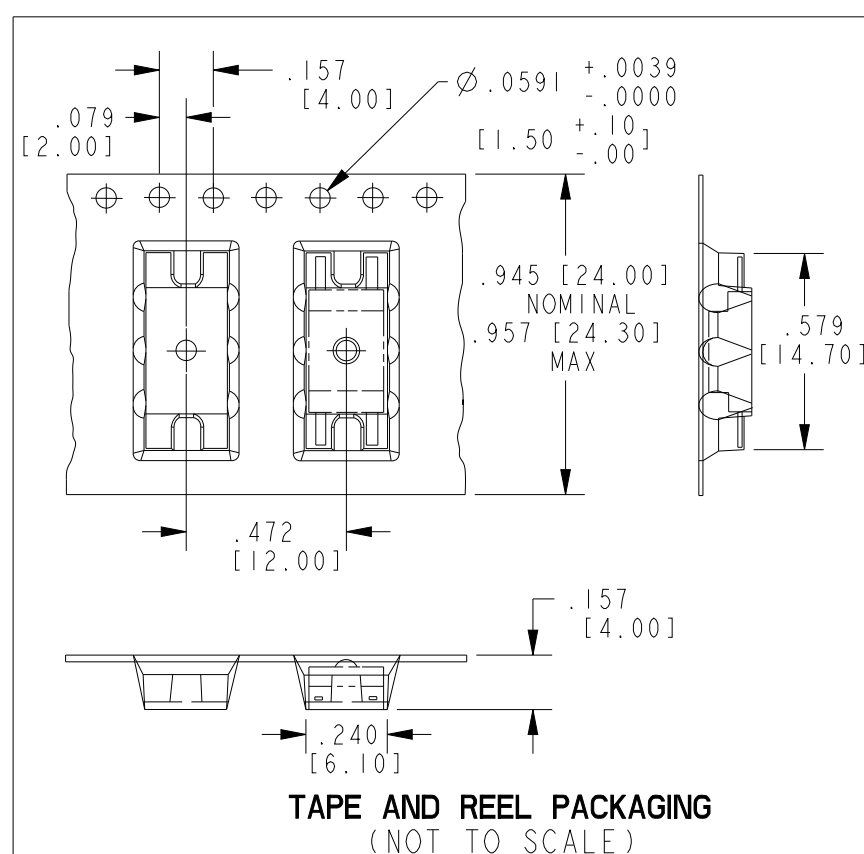
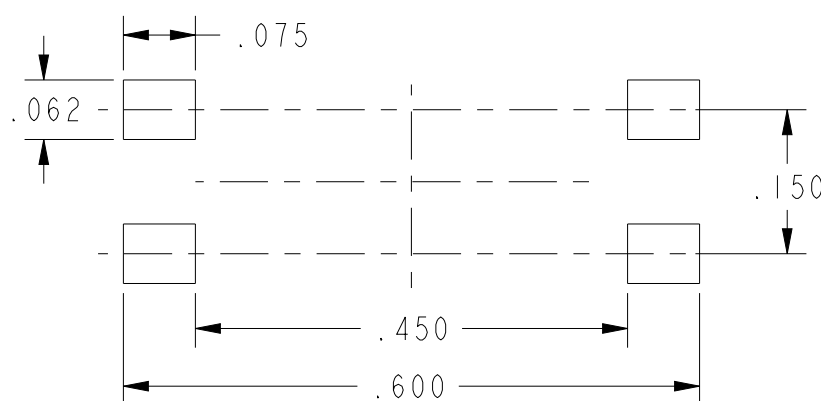

TUBE PACKAGING (NOT TO SCALE)

DESIGN UNITS: INCH	DRAWN	SAV	27JUL04
TOLERANCES UNLESS NOTED:	CHECK	SAV	27JUL04
NO PLACES X ± .400	THIS DRAWING COVERS A PROPRIETARY ITEM AND IS THE PROPERTY OF HONEYWELL. THIS DRAWING IS NOT TO BE COPIED OR USED WITHOUT THE PERMISSION OF HONEYWELL.		
ONE PLACE X ± .030			
TWO PLACE XX ± .015			
THREE PLACE XXX ± .005			
ANGLES X ± -			

THIRD ANGLE PROJECTION

INTERPRET PER ASME Y14.5M-1994 OTHER HONEYWELL ENGINEERING STANDARDS MAY APPLY	Pro/ENGINEER	3D	SCALE 8:1
--	--------------	----	-----------

Honeywell			
TITLE SENSOR, FORCE			
SIZE	TYPE	CAGE CODE	DRAWING NAME
C	I	-	FS SERIES CHART 1 8
SHEET 1 OF 1		REV	