

REV.	DESCRIPTION	DATE	APPROVED
A	Engineering Release	01/23/07	M. C.
B	Changed Outer Diameter from .232 to .225	03/28/07	M. C.
C	Added 0.168 Dimension	08/12/09	T. Y.
D	Removed Material Code	05/28/16	J. C.

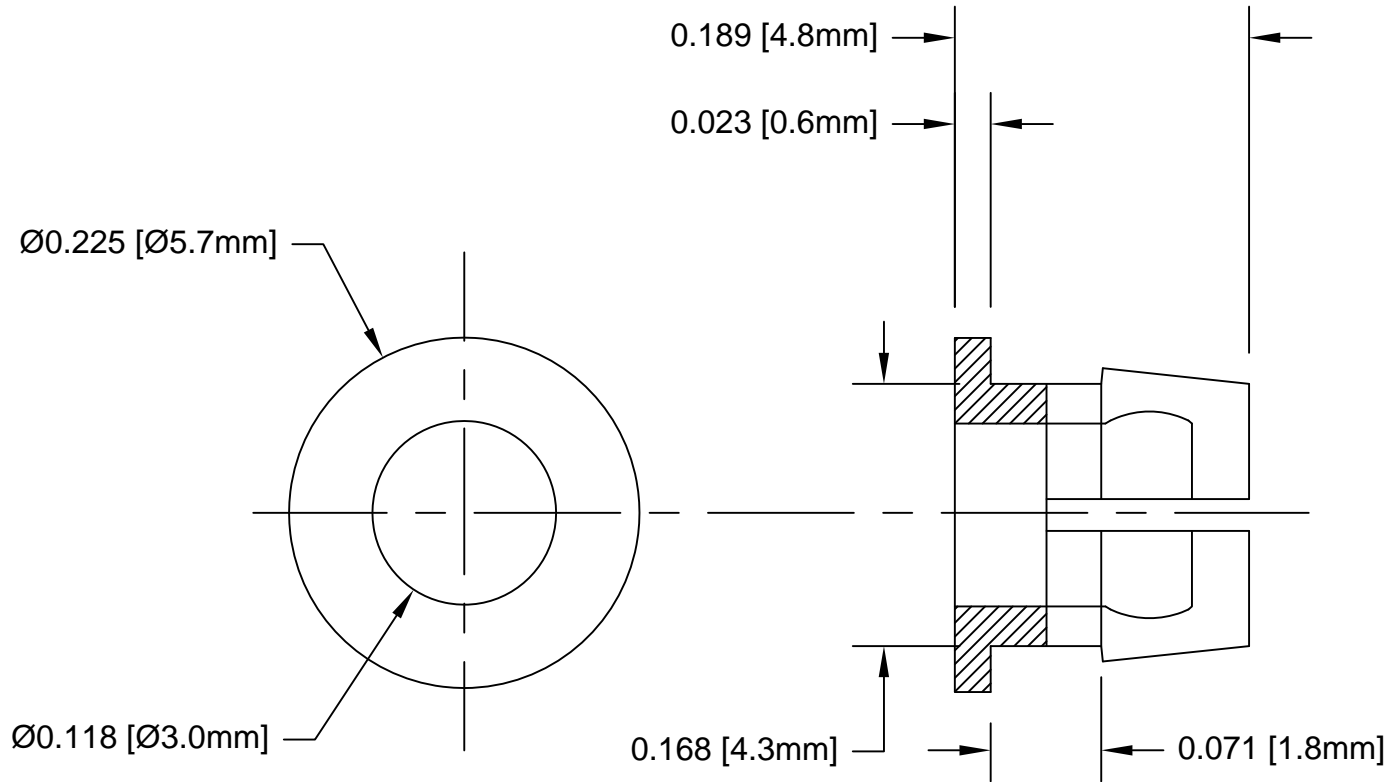
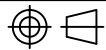

2. MATERIAL: NYLON 6/6, 94V-2, BLACK.

1. GENERAL SPECIFICATIONS: BIVAR MOLDED COMPONENT SPECIFICATION BV00-101.

STANDARD TOLERANCE (UNLESS OTHERWISE SPECIFIED)		BIVAR [®]	
DECIMALS	ANGULAR	4 THOMAS, IRVINE, CA. 92618	
.X ± .1	X° ± 1°	TEL: (949) 951-8808 FAX: (949) 951-3974	
.XX ± .01		 TITLE: T-1 (3mm) LED CLIP	
.XXX ± .005			
DESIGNED: S. Dam	DATE: 01/23/07	PART NO: C-101	REVISION: D
CHECKED: T. Yin	DATE: 01/23/07	CAGE CODE : 32559	SHEET # 1 OF 1
CAD GENERATED DOCUMENT. DO NOT MEASURE DRAWING.			