

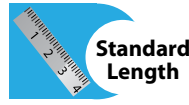

470-013
StarShield™ EMI/RFI Shield Termination Backshell
for MIL-DTL-38999 Series III and IV Connectors

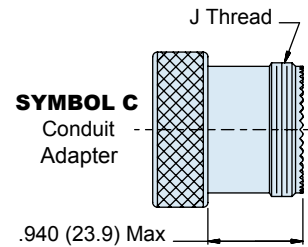

StarShield™ environmental backshell with self-nestor coupling and rear end options

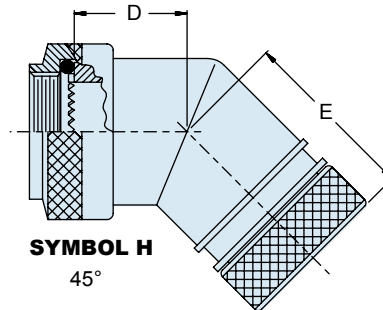
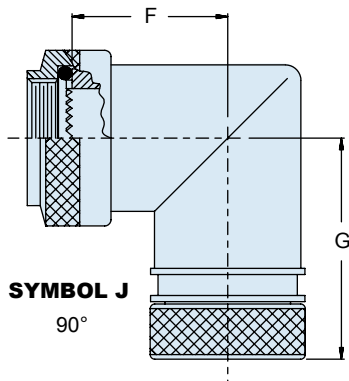
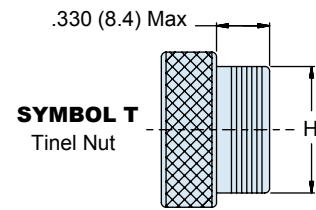
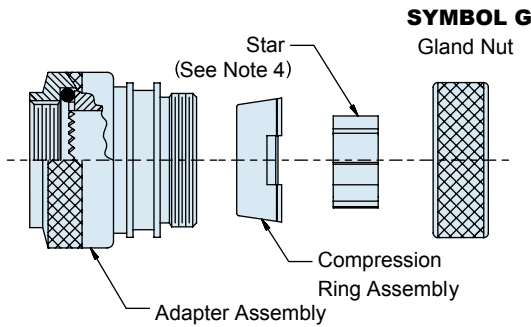
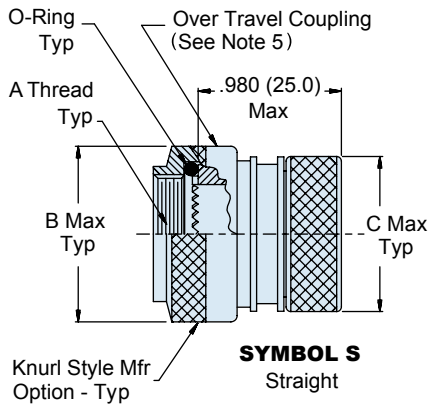
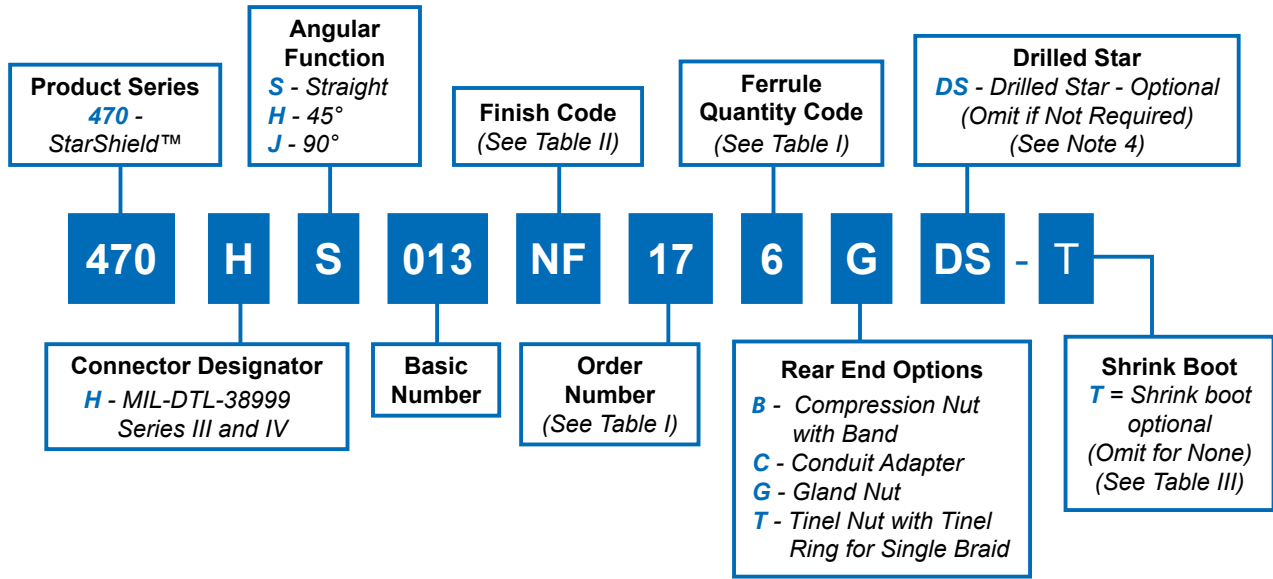

Dimensions in inches (millimeters) and are subject to change without notice.

470-013

StarShield™ EMI/RFI Shield Termination Backshell for MIL-DTL-38999 Series III and IV Connectors



Order No.	Connector Shell Size Ref	A Thread ISO Metric	B Dia Max	C Dia Max	D Max	E Max	F Max
09	A/9	M12 X 1 - 6H	.75 (19.0)	.690 (17.5)	.490 (12.5)	1.000 (25.4)	.630 (16.0)
11	B/11	M15 X 1 - 6H	.870 (22.0)	.850 (21.5)	.510 (13.0)	1.020 (26.0)	.690 (17.5)
13	C/13	M18 X 1 - 6H	1.000 (25.4)	.890 (22.5)	.550 (14.0)	1.040 (26.5)	.750 (19.0)
15	D/15	M22 X 1 - 6H	1.200 (30.5)	1.000 (25.4)	.570 (14.5)	1.080 (27.5)	.810 (20.5)
17	E/17	M25 X 1 - 6H	1.320 (33.5)	1.120 (28.5)	.590 (15.0)	1.100 ((28.0)	.870 (22.0)
19	F/19	M28 X 1 - 6H	1.460 (37.0)	1.240 (31.5)	.610 (15.5)	1.120 (28.5)	.930 (23.5)
21	G/21	M31 X 1 - 6H	1.520 (38.5)	1.380 (35.0)	.650 (16.5)	1.140 (29.0)	1.000 (25.4)
23	H/23	M34 X 1 - 6H	1.650 (42.0)	1.500 (38.0)	.670 (17.0)	1.180 (30.0)	1.060 (27.0)
25	J/25	M37 X 1 - 6H	1.830 (46.5)	1.610 (41.0)	.710 (18.0)	1.220 (31.0)	1.120 (28.5)

Order No.	G Max	H ± .003 (.08)	J Thread ISO Metric	K ± .004 (.10)	Ferrule Quantity (See Note 4)	
					Std.	Opt.
09	1.140 (29.0)	.435 (11.0)	M12 X 1 - 6g	.315 (8.00)	1	-
11	1.200 (30.5)	.623 (15.8)	M15 X 1 - 6g	.531 (13.5)	2	-
13	1.260 (32.0)	.746 (18.9)	M18 X 1 - 6g	.591 (15.0)	3	-
15	1.320 (33.5)	.871 (22.1)	M22 X 1 - 6g	.709 (18.0)	5	-
17	1.380 (35.0)	.996 (25.3)	M25 X 1 - 6g	.827 (21.0)	6	7
19	1.440 (36.5)	1.121 (28.5)	M28 X 1 - 6g	.945 (24.0)	7	-
21	1.520 (38.5)	1.245 (31.6)	M31 X 1 - 6g	1.063 (27.0)	9	11
23	1.570 (40.0)	1.371 (34.8)	M34 X 1 - 6g	1.181 (30.0)	10	13
25	1.630 (41.5)	1.371 (34.8)	M37 X 1 - 6g	1.299 (33.0)	12	17

Code	Material; Finish Description
M	Aluminum; electroless nickel
MT	Aluminum; nickel - PTFE
NF	Aluminum; CAD/O. D. over electroless nickel
ZN	Aluminum; zinc nickel/O. D. over electroless nickel
ZR	Aluminum; zinc nickel/black over electroless nickel (RoHS)
ZRC	Aluminum; zinc nickel over electroless nickel (RoHS)
Z1	Stainless steel; passivate
ZM	Stainless steel; electroless nickel

Material/Finish	
Backshell, elbows, coupling and gland nut, compression ring and star	Aluminum alloy or CRES/Table II
Tinel ring	Nickel-titanium alloy/n.a.
Band	CRES/Passivate
O-ring	Silicone/n.a.

Shell Size	Shrink Boot Part Number
09	770-001S1 04
11	770-001S1 06
13	770-001S1 06
15	770-001S1 07
17	770-001S1 07
19	770-001S1 08
21	770-001S1 08
23	770-001S1 08
25	770-001S1 09

Notes:

1. Assembly identified with manufacturer's name, part number and date code, space permitting.
2. For effective grounding, connector with conductive finish should be used.
3. Glenair 600 Series Backshell Assembly Tools are recommended for assembly and installation.
4. Star not supplied with Order Number 09. Drilled star is available on order numbers 15-25 only. If optional ferrule quantity per Table I is selected, one split and one solid star will be supplied.
5. Over-travel coupling design provides self-seating and self-locking functionality, eliminating lock-wire requirements.
6. Ferrule kit sold separately.
687-764 ferrule and HST device kit
687-809 ferrule and sealing device kit
687-748 solder ferrule
687-841-01 HST flex device

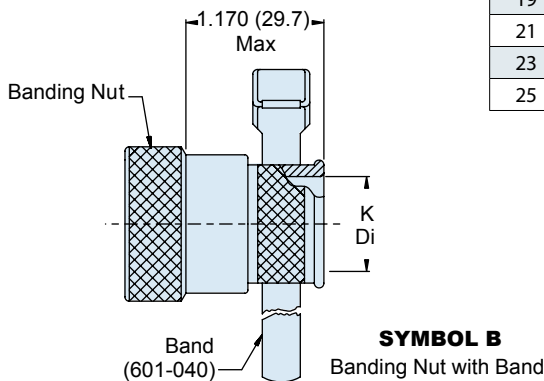

Dimensions in inches (millimeters) and are subject to change without notice.