

UNCONTROLLED DOCUMENT

PART NUMBER
SSI-LXR4815ID-B

REV.
C

REV.	E.C.N. NUMBER AND REVISION COMMENTS	DATE
A	UPDATED SAFE OPER. SPECS.	10.27.94
B	E.C.N. #10674.	10.30.00
C	E.C.N. #10BRDR. & REDRAWN IN 3D.	1.10.02

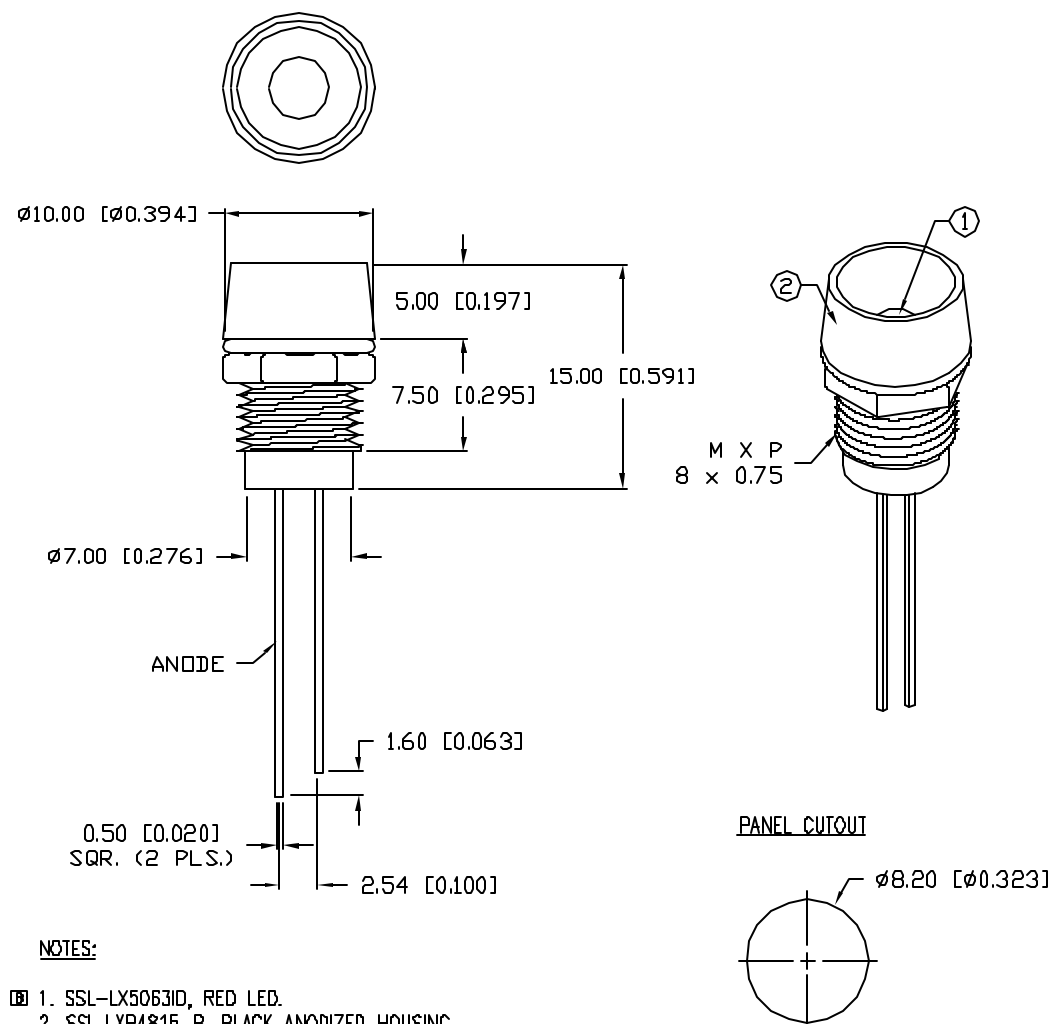

ELECTRO-OPTICAL CHARACTERISTICS $T_A=25^\circ\text{C}$ $I_f=20\text{mA}$

PARAMETER	MIN	TYP	MAX	UNITS	TEST COND
PEAK WAVELENGTH		635		nm	
FORWARD VOLTAGE		2.0	2.5	V_f	
REVERSE VOLTAGE	5.0			V_r	$I_f=100\mu\text{A}$
AXIAL INTENSITY		40		mcd	$I_f=20\text{mA}$
VIEWING ANGLE		60		$2x$ theta	
EMITTED COLOR:	RED				
EPOXY LENS FINISH:	RED DIFFUSED				

LIMITS OF SAFE OPERATION AT 25°C

PARAMETER	MAX	UNITS
PEAK FORWARD CURRENT*	150	mA
STEADY CURRENT	30	mA
POWER DISSIPATION	105	mW
DERATE FROM 25°C	-1.2	mW/ $^\circ\text{C}$
OPERATING, STORAGE TEMP.	-40 TO +85	$^\circ\text{C}$
SOLDERING TEMP.	+260	$^\circ\text{C}$
2.0mm FROM BODY		3 SEC. MAX

* $t < 10\mu\text{s}$

- NOTES:
1. SSL-LX5063ID, RED LED.
 2. SSI-LXR4815-B, BLACK ANODIZED HOUSING.
 3. SSH-LXH4815BSG, BLACK NYLON BUSHING. (NOT SHOWN).
 4. INSERT LED LEADS INTO BUSHING, THEN INSERT INTO HOUSING. CRIMP BUSHING INTO PLACE.

*UNLESS OTHERWISE SPECIFIED TOLERANCES PER DECIMAL PRECISION ARE: X= ± 1 (± 0.039), XX= ± 0.5 (± 0.020), XXX= ± 0.25 (± 0.010), XXXX= ± 0.127 (± 0.005). LEAD SIZE= ± 0.05 (± 0.002), LEAD LENGTH= ± 0.75 (± 0.030), MIN= $\begin{matrix} +0.00 \\ -0.00 \end{matrix}$ DECIMAL PRECISION, MAX= $\begin{matrix} +0.00 \\ -0.00 \end{matrix}$ DECIMAL PRECISION.

UNCONTROLLED DOCUMENT

REV. C	PART NUMBER SSI-LXR4815ID-B
-----------	--------------------------------

CONFIDENTIAL INFORMATION
THE INFORMATION CONTAINED IN THIS DOCUMENT IS THE PROPERTY OF LUMEX INC. EXCEPT AS SPECIFICALLY AUTHORIZED IN WRITING BY LUMEX INC., THE HOLDER OF THIS DOCUMENT SHALL KEEP ALL INFORMATION CONTAINED HEREIN CONFIDENTIAL AND SHALL PROTECT SAME IN WHOLE OR IN PART FROM DISCLOSURE AND DISSEMINATION TO ALL THIRD PARTIES.



290 E. HELEN ROAD
PALATINE, IL 60067-6976
PHONE: +1.847.359.2790
US WEB: www.lumex.com
TW WEB: www.lumex.com.tw

T-5mm 635nm RED LED PANEL INDICATOR,
RED DIFFUSED LENS.

RELIABILITY NOTE
OUR MANY YEARS OF EXPERIENCE DATA ACCUMULATION INDICATE THAT SOLDER HEAT IS A MAJOR CAUSE OF EARLY AND FUTURE FAILURE. PLEASE PAY ATTENTION TO YOUR SOLDERING PROCESS.

DRAWN BY: BC	CHECKED BY:	APPROVED BY:	DATE: 10.2.90 PAGE: 1 OF 1 SCALE: N/A
-----------------	-------------	--------------	---