



LT Series
Basic Evaluation Kit
User's Guide

Wireless made simple[®]



Warning: Linx radio frequency ("RF") products may be used to control machinery or devices remotely, including machinery or devices that can cause death, bodily injuries, and/or property damage if improperly or inadvertently triggered, particularly in industrial settings or other applications implicating life-safety concerns. No Linx Technologies product is intended for use in any application without redundancies where the safety of life or property is at risk.

The customers and users of devices and machinery controlled with RF products must understand and must use all appropriate safety procedures in connection with the devices, including without limitation, using appropriate safety procedures to prevent inadvertent triggering by the user of the device and using appropriate security codes to prevent triggering of the remote controlled machine or device by users of other remote controllers.

Do not use this or any Linx product to trigger an action directly from the data line or RSSI lines without a protocol or encoder/decoder to validate the data. Without validation, any signal from another unrelated transmitter in the environment received by the module could inadvertently trigger the action. This module does not have data validation built in.

All RF products are susceptible to RF interference that can prevent communication. RF products without frequency agility or hopping implemented are more subject to interference. This module does not have frequency agility built in.

Do not use any Linx product over the limits in this data guide. Excessive voltage or extended operation at the maximum voltage could cause product failure. Exceeding the reflow temperature profile could cause product failure which is not immediately evident.

Do not make any physical or electrical modifications to any Linx product. This will void the warranty and regulatory and UL certifications and may cause product failure which is not immediately evident.

Table of Contents

- 1 [Introduction](#)
- 2 [Ordering Information](#)
- 3 [LT Series Transceiver Evaluation Board](#)
- 3 [Board Objects](#)
- 4 [Theory of Operation](#)
- 4 [Using the Kit](#)
- 5 [Development Using the Prototyping Area](#)
- 6 [Range Testing](#)
- 7 [Using the Boards as a Design Reference](#)
- 8 [About Antennas](#)
- 8 [In Closing](#)
- 9 [Online Resources](#)
- 10 [Transceiver Evaluation Board Schematics](#)

LT Series Basic Evaluation Kit

User's Guide

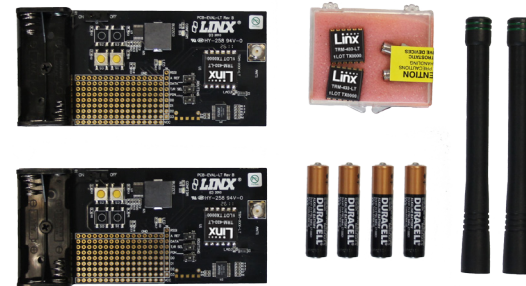

Figure 1: LT Series Basic Evaluation Kit

Introduction

LinX LT Series RF transceiver modules offer a simple, efficient and cost-effective method of adding wireless communication capabilities to any product. The Basic Evaluation Kit gives a designer all the tools necessary to correctly and legally incorporate the LT Series modules into an end product. The evaluation boards themselves serve several important functions:

- **Rapid Module Evaluation:** The boards allow the performance of the LT Series modules to be evaluated quickly in a user's environment.
- **Range Testing:** Using the on-board transcoders to generate a duplex transmission, a pair of evaluation boards can be used to evaluate the range performance of the modules.
- **Design Benchmark:** The boards provide a known benchmark against which the performance of a custom design may be judged.
- **Application Development:** An onboard prototyping area allows for the development of custom circuits directly on the evaluation board. All signal lines are available on a header for easy access.

This kit includes 4 LT Series transceivers*†, 2 MT Series transcoders*, 2 extra PCB-mount RP-SMA connectors, 2 evaluation boards, 2 HD or CW Series antennas, 4 AAA batteries, and full documentation.

* One part is soldered to each board.

† Two extras are for use on your first prototype boards.

Ordering Information

Ordering Information	
Part Number	Description
EVAL-***-LT	LT Series Basic Evaluation Kit
*** = 315, 418 (Standard), 433MHz	

Figure 2: Ordering Information

Warning: This product incorporates numerous static-sensitive components. Always wear an ESD wrist strap and observe proper ESD handling procedures when working with this device. Failure to observe this precaution may result in module damage or failure.

LT Series Transceiver Evaluation Board

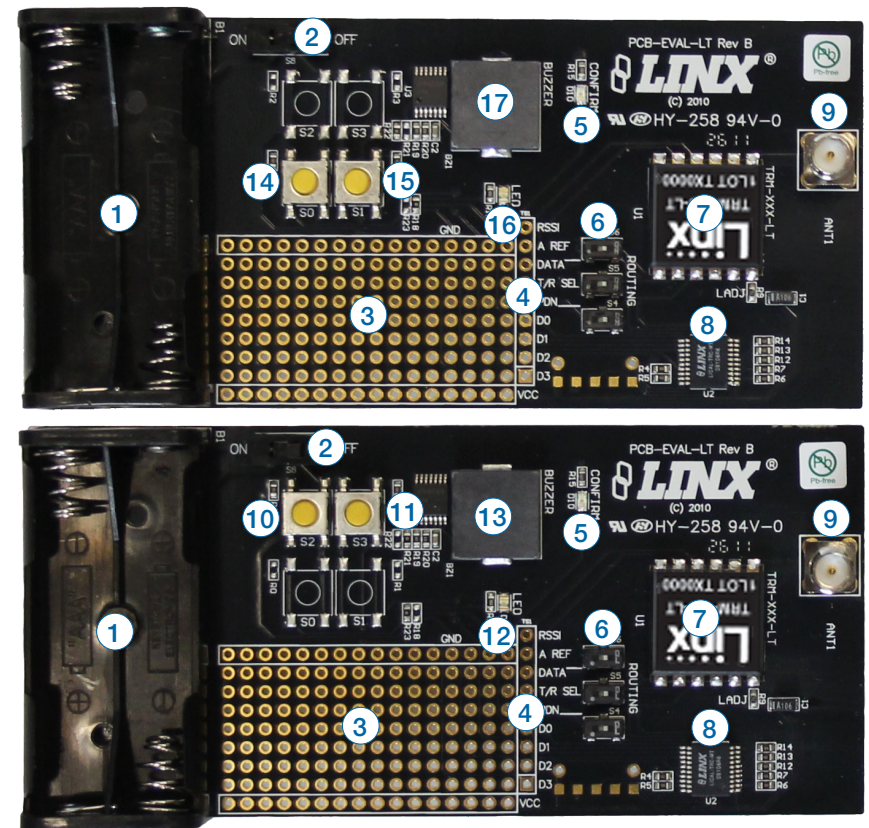

Figure 3: LT Series Transceiver Evaluation Boards

Board Objects

- | | |
|---------------------------------|------------------------|
| 1. Battery – 3VDC | 10. LED Button – D2 |
| 2. Power Switch | 11. Buzzer Button – D3 |
| 3. Prototyping Area | 12. LED – D0 |
| 4. Breakout Header | 13. Buzzer – D1 |
| 5. Confirmation LED | 14. LED Button – D0 |
| 6. Routing Switches | 15. Buzzer Button – D1 |
| 7. LT Series Transceiver Module | 16. LED – D2 |
| 8. MT Series Transcoder Chip | 17. Buzzer – D3 |
| 9. RP-SMA Antenna Connector | |

Theory of Operation

The two transceiver evaluation boards are identical, but they are populated slightly differently. The MT Series transcoder is both an encoder and a decoder, with the input or output nature of each line being determined by how the board is populated. One board has buttons S0 and S1 populated, making those lines inputs. On the other board, those lines are connected to the buzzer and LED, respectively. Conversely, the first board has lines D2 and D3 connected to the buzzer and LED, while the second board has buttons S2 and S3 populated. This allows for bidirectional remote control. To use the kit, simply attach the antennas, turn on the power, and press one or both of the buttons on a board. When S0 or S2 is pressed, the buzzer sounds; when S1 or S3 is pressed, the LED turns on.

Both boards have a confirmation LED. When one transcoder sends a command to the second transcoder, the second transcoder sends a confirmation back to the first transcoder indicating that the command was received and the action performed. When the first transcoder receives the confirmation, it turns on the CONFIRM LED to indicate this. This feature offers the ability to range test without needing to be in visual or hearing range of both boards.

The MT Series Transcoder Data Guide goes into the many features of the transcoders in detail, but this is the only set-up required for operation of this kit.

Using the Kit

Using the kit is straightforward. Simply attach the antennas, turn on the power, and press buttons on one of the boards. When S0 or S2 is pressed, the LED turns on; when S1 or S3 is pressed, the buzzer sounds. When any button is pressed, the CONFIRM LED lights up to indicate that the other side got the command.

Development Using the Prototyping Area

In addition to their evaluation functions, the boards may also be used for product development. They feature a prototyping area to facilitate the addition of application-specific circuitry. This area has a connection to V_{CC} at the bottom and to ground at the top which can be used to power any added circuitry.

Note: If added circuitry requires a higher current than can be provided by the batteries, the batteries must be removed and the board powered from an external source.

The holes are plated and set at 0.1" on center with a 0.04" diameter, making it easy to add most industry-standard SIP and DIP packages to the board.

All of the lines from the transceiver have been wired out to a row of plated holes on the right side of the prototyping area. Four of the data lines from the transcoder have also been wired out. This allows for easy access to connect external circuitry to the modules and the transcoder. Three lines from the transceiver (DATA, T/\bar{R}_{SEL} , and PDN) have been routed to switches. The switches connect the lines to either the transcoder or the prototyping area. This allows the transceiver to be conveniently switched between the transcoder and application circuitry during testing.

Range Testing

Several complex mathematical models exist for determining path loss in many environments. These models vary as the transmitter and receiver are moved from indoor operation to outdoor operation. Although these models can provide an estimation of range performance in the field, the most reliable method is to simply perform range tests using the transmitter and receiver in the intended operational environment.

Basic range testing can be performed with the transceiver evaluation boards. To prepare the board for range testing, turn it on by switching the power switch to the ON position. Pressing S0 or S2 activates the buzzer on the receiver board, while S1 or S3 activates the LED. The CONFIRM LED provides an indication that the signal has traveled round trip, so only one person is needed to conduct range testing.

As the maximum range of the link in an area is approached, it is not uncommon for the signal to cut in and out as the transmitter moves. This is normal and can result from other interfering sources or fluctuating signal levels due to multipath. Multipath results in cancellation of the transmitted signal as direct and reflected signals arrive at the receiver at differing times and phases. The areas in which this occurs are commonly called “nulls” and simply walking a little further usually restores the signal. If this does not restore the signal, then the maximum effective range of the link has been reached.

Since the evaluation boards are intended for use by design engineers, they are not FCC certified. The transmitter section has been set to approximate legal limits by resistor R9 so that the range test results will approximate the results from a well-designed, certified product. For applications where Part 15 limits are not applicable or output levels can be legally raised due to protocol duty cycle, R9 can be changed according to the Output Power vs. LADJ Resistance graph in the LT Series Transceiver Module Data Guide.

To achieve maximum range, keep objects such as your hand away from the antenna and ensure that the antenna on the transmitting board has a clear and unobstructed line-of-sight path to the receiving board. Range performance is determined by many interdependent factors. If the range you are able to achieve is significantly less than specified by Linx for the products you are testing, then there is likely a problem with either the board or the ambient RF environment in which the board is operating. First, check the battery, switch positions, and antenna connection. Next, measure the

transceiver's RSSI voltage with the other transceiver turned off to determine if ambient interference is present. If this fails to resolve the issue, please contact Linx technical support.

Using the Boards as a Design Reference

The basic evaluation boards included in this kit are very simple, yet they illustrate some important techniques that should be incorporated into the board layout. The module's mounting pads extend slightly past the edge of the part. This eases hand assembly and allows for better heat conduction under the part if rework is necessary. A full ground plane fill is placed on the bottom of the board. This ground plane serves three important purposes:

First, since a quarter-wave antenna is employed, the ground plane is critical to serve as a counterpoise (please see Application Note AN-00500 “Antennas: Design, Application, and Performance” for details on how a ground plane affects antenna function).

Second, a ground plane suppresses the transfer of noise between stages of a product as well as unintentional radiation of noise into free space.

Third, a ground plane allows for the implementation of a microstrip feed between the module and the antenna. The term microstrip refers to a PCB trace running over a ground plane that is designed to serve as a 50-ohm transmission line. See the LT Series data guide or the calculator available on our website for details on microstrip calculations.

About Antennas

The choice of antennas is one of the most critical and often overlooked design considerations. The range, performance, and legality of an RF link are critically dependent upon the type of antenna employed. Linx offers a variety of antenna styles that can be considered for a design. Included with your kit are HD Series (315MHz) or CW Series (418MHz and 433MHz) connectorized whip antennas that should be connected prior to using the kit. Despite the fact that the antenna is not centered on the board's ground plane, it exhibits a VSWR of <1.7 and suitably demonstrates the module's best practical performance.

In Closing

Here at Linx, "Wireless Made Simple" is more than just our motto, it is our commitment. A commitment to the highest caliber of product, service, and support. That is why, should you have questions or encounter any difficulties using the evaluation kit, you'll be glad to know many resources are available to assist you. First, check carefully for the obvious, then visit our website at www.linxtechnologies.com or call +1 541 471 6256 between 8AM and 4PM Pacific Time to speak with an application engineer.

Legal Notice: All Linx kits and modules are designed in keeping with high engineering standards; however, it is the responsibility of the user to ensure that the products are operated in a legal and appropriate manner. The purchaser understands that legal operation may require additional permits, approvals, or certifications prior to use, depending on the country of operation.

Online Resources

www.linxtechnologies.com

If you have questions regarding any Linx product and have Internet access, make www.linxtechnologies.com your first stop. Day or night, the Linx website gives you instant access to the latest information regarding the products and services of Linx. It's all here, including:

- **Manual and Software Updates**
- **Latest News**
- **Data Guides**
- **Application Notes**
- **Knowledgebase**
- **FCC Information**

And much more. Be sure to visit often!

www.antennafactor.com

The Antenna Factor division of Linx offers a diverse array of antenna styles, many of which are optimized for use with our RF modules. From innovative embeddable antennas to low-cost whips, domes to GPS antennas, Antenna Factor likely has an antenna for you, or can design one to meet your requirements.

AntennaFactor
by **Linx**



Figure 4: Antenna Factor Antennas

Transceiver Evaluation Board Schematics

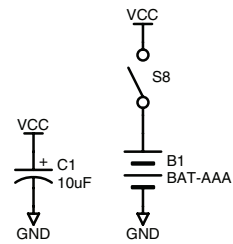

Figure 5: Power Supply Section

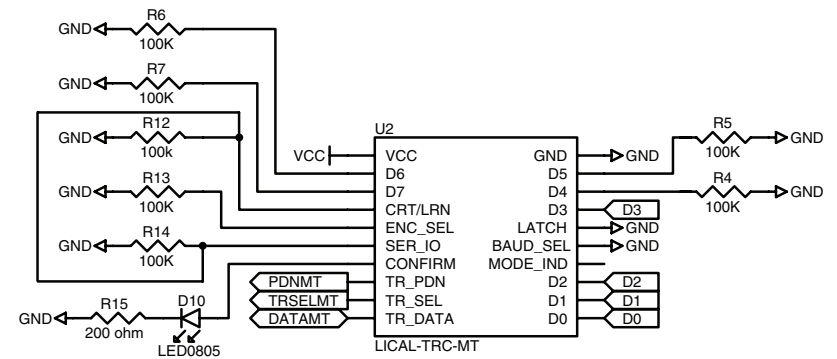
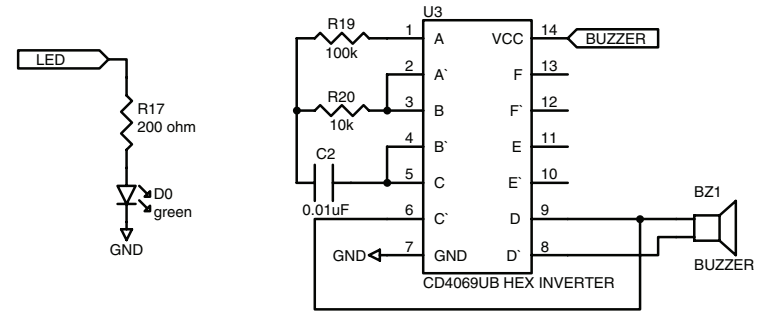

Figure 6: RF Module Section

Figure 8: Duplex Range Test Section

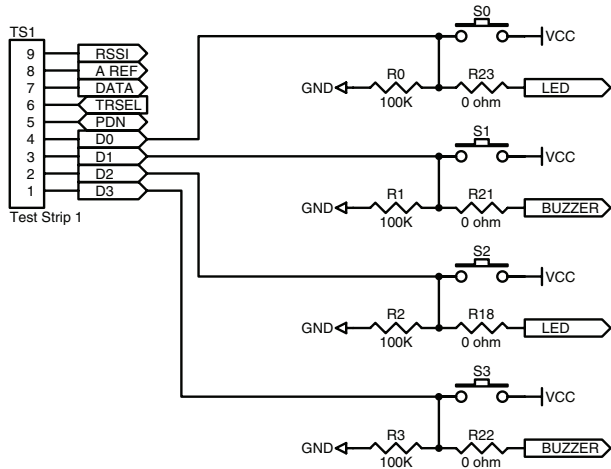

Figure 7: Header Section



Linx Technologies
159 Ort Lane
Merlin, OR, US 97532

Phone: +1 541 471 6256
Fax: +1 541 471 6251

www.linxtechnologies.com

Disclaimer

Linx Technologies is continually striving to improve the quality and function of its products. For this reason, we reserve the right to make changes to our products without notice. The information contained in this Data Guide is believed to be accurate as of the time of publication. Specifications are based on representative lot samples. Values may vary from lot-to-lot and are not guaranteed. "Typical" parameters can and do vary over lots and application. Linx Technologies makes no guarantee, warranty, or representation regarding the suitability of any product for use in any specific application. It is the customer's responsibility to verify the suitability of the part for the intended application. **NO LINX PRODUCT IS INTENDED FOR USE IN ANY APPLICATION WHERE THE SAFETY OF LIFE OR PROPERTY IS AT RISK.**

Linx Technologies **DISCLAIMS ALL WARRANTIES OF MERCHANTABILITY AND FITNESS FOR A PARTICULAR PURPOSE. IN NO EVENT SHALL LINX TECHNOLOGIES BE LIABLE FOR ANY OF CUSTOMER'S INCIDENTAL OR CONSEQUENTIAL DAMAGES ARISING IN ANY WAY FROM ANY DEFECTIVE OR NON-CONFORMING PRODUCTS OR FOR ANY OTHER BREACH OF CONTRACT BY LINX TECHNOLOGIES.** The limitations on Linx Technologies' liability are applicable to any and all claims or theories of recovery asserted by Customer, including, without limitation, breach of contract, breach of warranty, strict liability, or negligence. Customer assumes all liability (including, without limitation, liability for injury to person or property, economic loss, or business interruption) for all claims, including claims from third parties, arising from the use of the Products. The Customer will indemnify, defend, protect, and hold harmless Linx Technologies and its officers, employees, subsidiaries, affiliates, distributors, and representatives from and against all claims, damages, actions, suits, proceedings, demands, assessments, adjustments, costs, and expenses incurred by Linx Technologies as a result of or arising from any Products sold by Linx Technologies to Customer. Under no conditions will Linx Technologies be responsible for losses arising from the use or failure of the device in any application, other than the repair, replacement, or refund limited to the original product purchase price. Devices described in this publication may contain proprietary, patented, or copyrighted techniques, components, or materials. Under no circumstances shall any user be conveyed any license or right to the use or ownership of such items.

©2015 Linx Technologies. All rights reserved.

The stylized Linx logo, Wireless Made Simple, WISE, CipherLinx and the stylized CL logo are trademarks of Linx Technologies.