

THIS IS ISSUED IN STRICT CONFIDENCE THAT IT IS NOT USED AS A BASIS FOR MANUFACTURE OR SALE AND THAT IT IS NOT COPIED, REPRINTED OR DISCLOSED TO A THIRD PARTY EITHER WHOLLY OR IN PART WITHOUT THE PRIOR WRITTEN CONSENT OF CAL TEST ELECTRONICS, INC.

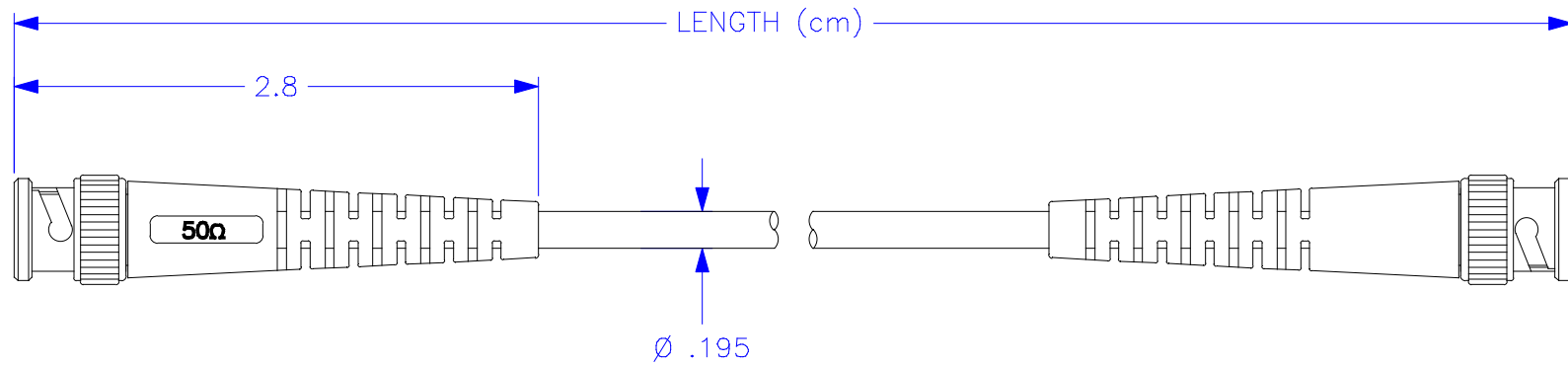

DRAWN		10/20/02		SIZE	CAGE CODE	DWG. NO.	REV.
WDH				A		P294200	-
CHECKED				SCALE	1:1	SHEET	2 OF 2