

Silicon Standard Recovery Diode

$V_{RRM} = 700\text{ V} - 1000\text{ V}$

$I_F = 35\text{ A}$

Features

- High Surge Capability
- Types from 700 V to 1000 V V_{RRM}
- Not ESD Sensitive

Note:

1. Standard polarity: Stud is cathode.
2. Reverse polarity (R): Stud is anode.
3. Stud is base.

DO-5 Package

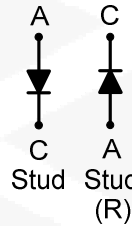

Maximum ratings, at $T_j = 25\text{ }^\circ\text{C}$, unless otherwise specified

Parameter	Symbol	Conditions	1N3765 (R)	1N3766 (R)	1N3767 (R)	1N3768 (R)	Unit
Repetitive peak reverse voltage	V_{RRM}		700	800	900	1000	V
RMS reverse voltage	V_{RMS}		490	560	630	700	V
DC blocking voltage	V_{DC}		700	800	900	1000	V
Continuous forward current	I_F	$T_C \leq 140\text{ }^\circ\text{C}$	35	35	35	35	A
Surge non-repetitive forward current, Half Sine Wave	$I_{F,SM}$	$T_C = 25\text{ }^\circ\text{C}$, $t_p = 8.3\text{ ms}$	475	475	475	475	A
Operating temperature	T_j		-55 to 150	-55 to 150	-55 to 150	-55 to 150	$^\circ\text{C}$
Storage temperature	T_{stg}		-55 to 150	-55 to 150	-55 to 150	-55 to 150	$^\circ\text{C}$

Electrical characteristics, at $T_j = 25\text{ }^\circ\text{C}$, unless otherwise specified

Parameter	Symbol	Conditions	1N3765 (R)	1N3766 (R)	1N3767 (R)	1N3768 (R)	Unit
Diode forward voltage	V_F	$I_F = 35\text{ A}$, $T_j = 25\text{ }^\circ\text{C}$	1.2	1.2	1.2	1.2	V
Reverse current	I_R	$V_R = 50\text{ V}$, $T_j = 25\text{ }^\circ\text{C}$	10	10	10	10	μA
		$V_R = 50\text{ V}$, $T_j = 140\text{ }^\circ\text{C}$	10	10	10	10	mA

Thermal characteristics

Thermal resistance, junction - case	R_{thJC}		0.25	0.25	0.25	0.25	$^\circ\text{C/W}$
-------------------------------------	------------	--	------	------	------	------	--------------------

Figure .1-Typical Forward Characteristics

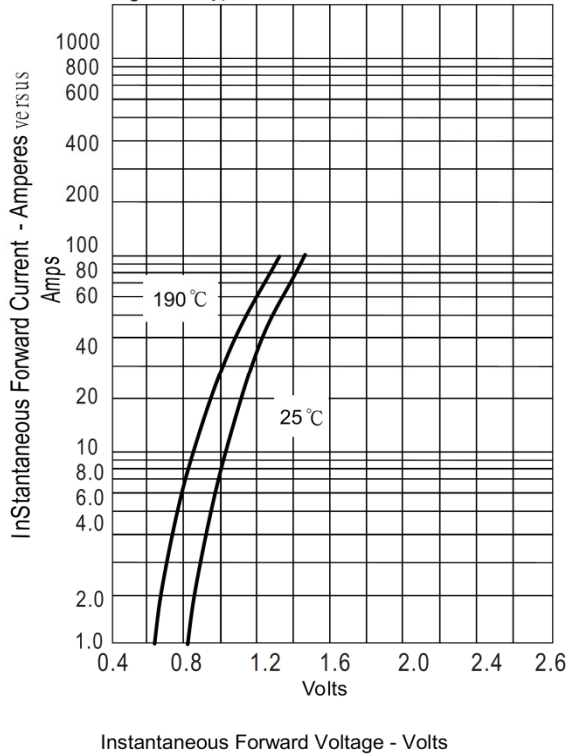
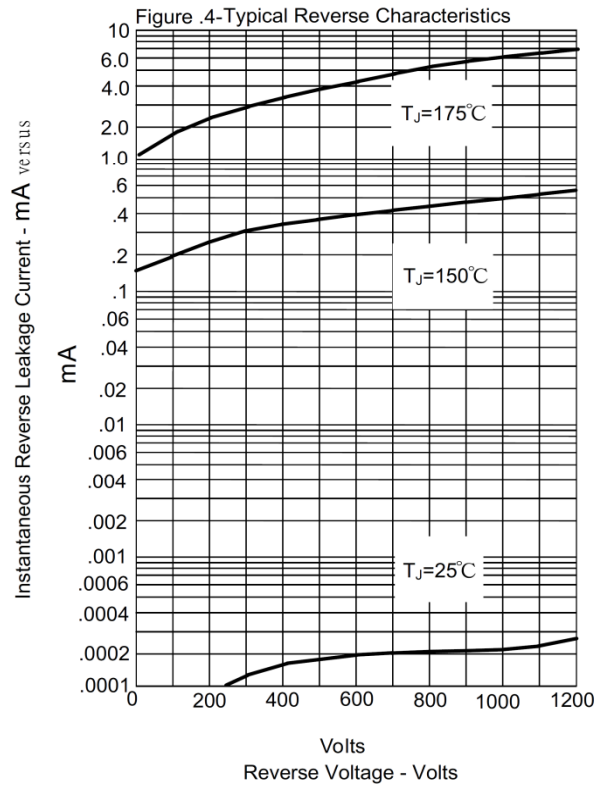
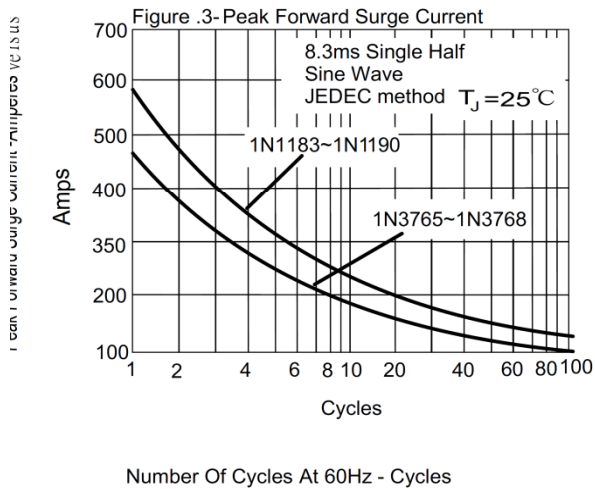
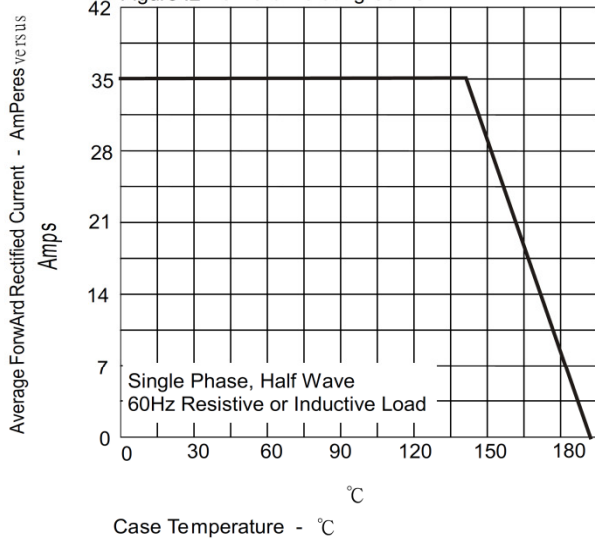
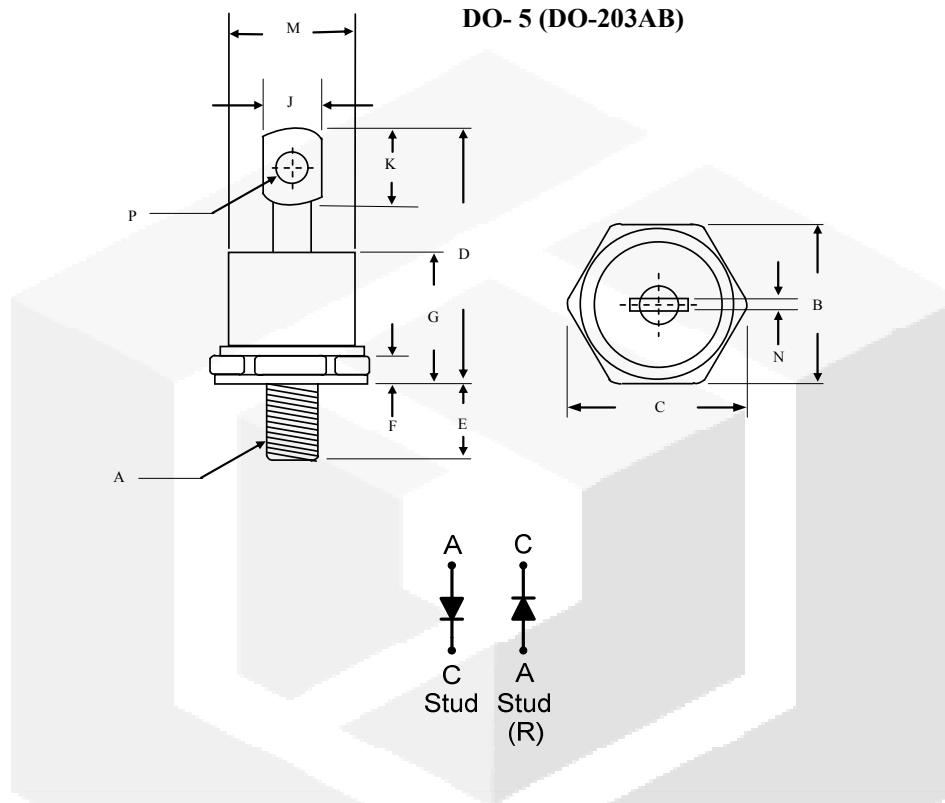

Figure .2-Forward Derating Curve



Package dimensions and terminal configuration

Product is marked with part number and terminal configuration.



	Inches		Millimeters	
	Min	Max	Min	Max
A	1/4-28 UNF			
B	0.669	0.687	17.19	17.44
C	----	0.794	----	20.16
D	----	1.020	----	25.91
E	0.422	0.453	10.72	11.50
F	0.115	0.200	2.93	5.08
G	----	0.460	----	11.68
J	----	0.280	----	7.00
K	0.236	----	6.00	----
M	----	0.589	----	14.96
N	----	0.063	----	1.60
P	0.140	0.175	3.56	4.45