

Intel® RealSense™ D400 Series Product Family

Datasheet

Intel® RealSense™ Vision Processor D4, Intel® RealSense™ Vision Processor D4 Board, Intel® RealSense™ Depth Module D400, Intel® RealSense™ Depth Module D410, Intel® RealSense™ Depth Module D415, Intel® RealSense™ Depth Camera D415, Intel® RealSense™ Depth Module D420, Intel® RealSense™ Depth Module D430, Intel® RealSense™ Depth Camera D435, Intel® RealSense™ Depth Camera D435i

Revision 005

January 2019



Intel products described herein. You agree to grant Intel a non-exclusive, royalty-free license to any patent claim thereafter drafted which includes subject matter disclosed herein.

No license (express or implied, by estoppel or otherwise) to any intellectual property rights is granted by this document.

Intel technologies' features and benefits depend on system configuration and may require enabled hardware, software or service activation. Performance varies depending on system configuration. No computer system can be absolutely secure. Check with your system manufacturer or retailer or learn more at intel.com.

Intel technologies may require enabled hardware, specific software, or services activation. Check with your system manufacturer or retailer.

The products described may contain design defects or errors known as errata which may cause the product to deviate from published specifications. Current characterized errata are available on request.

Intel disclaims all express and implied warranties, including without limitation, the implied warranties of merchantability, fitness for a particular purpose, and non-infringement, as well as any warranty arising from course of performance, course of dealing, or usage in trade.

All information provided here is subject to change without notice. Contact your Intel representative to obtain the latest Intel product specifications and roadmaps.

Copies of documents which have an order number and are referenced in this document may be obtained by calling 1-800-548-4725 or visit www.intel.com/design/literature.htm.

Intel and the Intel logo, Intel® Core™, Intel® Atom™, trademarks of Intel Corporation in the U.S. and/or other countries.

*Other names and brands may be claimed as the property of others.

© 2019 Intel Corporation. All rights reserved.

Contents

| | | |
|--------|---|----|
| 1 | Description and Features | 11 |
| 2 | Introduction | 12 |
| 2.1 | Purpose and Scope of this Document..... | 12 |
| 2.2 | Terminology | 12 |
| 2.3 | Stereo Vision Depth Technology Overview..... | 13 |
| 2.4 | Camera System Block Diagram..... | 15 |
| 2.5 | Intel® RealSense™ Depth Module D400 series Product SKUs | 16 |
| 2.6 | Intel® RealSense™ Depth Camera D400 series Product SKUs | 17 |
| 3 | Component Specification | 18 |
| 3.1 | Vision Processor D4 Camera System Components | 18 |
| 3.2 | Host Processor | 18 |
| 3.3 | Intel® RealSense™ Vision Processor D4 | 18 |
| 3.3.1 | Vision Processor D4 Features | 18 |
| 3.3.2 | Vision Processor D4 Signal Description | 19 |
| 3.3.3 | Vision Processor D4 Package Mechanical Attributes | 24 |
| 3.3.4 | Vision Processor D4 Power Requirements..... | 30 |
| 3.3.5 | Vision Processor D4 Power Sequencing..... | 30 |
| 3.3.6 | Vision Processor D4 Spec Code..... | 31 |
| 3.3.7 | Vision Processor D4 Storage and Operating Conditions | 31 |
| 3.3.8 | Vision Processor D4 Thermals | 32 |
| 3.4 | Clock..... | 32 |
| 3.5 | Serial (SPI) Flash Memory..... | 32 |
| 3.6 | Stereo Depth Module..... | 32 |
| 3.6.1 | Left and Right Imagers..... | 34 |
| 3.6.2 | Infrared Projector | 35 |
| 3.6.3 | Color Sensor | 36 |
| 3.6.4 | Depth Module Connector | 37 |
| 3.6.5 | Stereo Depth Module Label | 37 |
| 3.6.6 | Stiffener | 38 |
| 3.6.7 | Temperature Sensor | 38 |
| 3.6.8 | Other Stereo Depth Module Components | 38 |
| 3.6.9 | Mechanical Dimensions..... | 39 |
| 3.6.10 | Stereo Depth Module Power Sequence..... | 40 |
| 3.6.11 | Stereo Depth Module Storage and Operating Conditions | 40 |
| 3.7 | Intel® RealSense™ Vision Processor D4 Board | 41 |
| 3.7.1 | Mechanical Dimensions..... | 42 |
| 3.7.2 | Depth Module Receptacle..... | 42 |
| 3.7.3 | Flex and Rigid Interposer Interconnect | 42 |
| 3.7.4 | External Sensor Sync Connector | 47 |
| 3.7.5 | USB Peripheral Connector – Type-C | 47 |
| 3.7.6 | Color Image Signal Processor (ISP)..... | 49 |
| 3.7.7 | Vision Processor D4 Board Power Requirements | 49 |
| 3.7.8 | Vision Processor D4 Board Thermals | 49 |
| 3.7.9 | Vision Processor D4 Board Storage and Operating Conditions | 50 |
| 3.7.10 | Intel® RealSense™ Vision Processor D4 Board Product Identifier and Material Code..... | 50 |
| 3.8 | Intel® RealSense™ Depth Camera D400 Series..... | 50 |

| | | | |
|---|-------|--|----|
| | 3.8.1 | Depth Camera D400 Series Mechanical Dimensions | 51 |
| | 3.8.2 | Depth Camera D400 Series Thermals | 52 |
| | 3.8.3 | Depth Camera D400 Series Storage and Operating Conditions | 52 |
| | | (1) Controlled conditions should be used for long term storage of product. (2) Short exposure represents temporary max limits acceptable for transportation conditions. | 53 |
| | 3.8.4 | Depth Camera D400 Series Product Identifier and Material Code ... | 53 |
| | 3.8.5 | Camera Lens Cleaning Procedure..... | 53 |
| 4 | | Functional Specification | 54 |
| | 4.1 | Vendor Identification (VID) and Device Identification (DID)..... | 54 |
| | 4.2 | Vision Processor D4 Data Streams | 54 |
| | 4.3 | Depth Field of View (FOV) | 57 |
| | 4.4 | Depth Field of View at Distance (Z) | 57 |
| | 4.5 | Invalid Depth Band | 58 |
| | 4.6 | Minimum-Z Depth | 60 |
| | 4.7 | Depth Quality Specification | 60 |
| | 4.8 | Measured Power | 62 |
| | 4.9 | Depth Start Point (Ground Zero Reference) | 63 |
| | 4.9.1 | Depth Origin X-Y Coordinates | 65 |
| | 4.10 | Depth Camera Functions..... | 66 |
| | 4.11 | Color Camera Functions..... | 67 |
| | 4.12 | IMU Specifications..... | 68 |
| 5 | | Firmware | 69 |
| | 5.1 | Update | 69 |
| | 5.1.1 | Update Limits..... | 69 |
| | 5.2 | Recovery | 69 |
| 6 | | Software..... | 70 |
| | 6.1 | Intel® RealSense™ Software Development Kit 2.0..... | 70 |
| 7 | | System Integration | 71 |
| | 7.1 | System Level Block Diagram | 71 |
| | 7.2 | Vision Processor D4 System Integration..... | 71 |
| | 7.2.1 | Vision Processor D4 Board | 71 |
| | 7.2.2 | Vision Processor D4 on Motherboard | 72 |
| | 7.3 | D4 Camera System Power Delivery | 73 |
| | 7.4 | Vision Processor D4 Board for Integrated Peripheral..... | 74 |
| | 7.4.1 | USB 3.1 Gen 1 Receptacle | 74 |
| | 7.4.2 | USB 3.1 Gen 1 High Speed Cable Assembly | 74 |
| | 7.4.3 | Transmit to Receive Crossover | 75 |
| | 7.4.4 | Motherboard Receptacle | 76 |
| | 7.4.5 | Vision Processor D4 Board for Integrated Peripheral Power Requirements..... | 76 |
| | 7.5 | Thermals | 76 |
| | 7.6 | Stereo Depth Module Flex | 78 |
| | 7.7 | Stereo Depth Module Mounting Guidance | 78 |
| | 7.7.1 | Screw Mount..... | 78 |
| | 7.7.2 | Bracket Mount..... | 79 |
| | 7.7.3 | Stereo Depth Module Air gap..... | 81 |
| | 7.8 | Thermal Interface Material | 81 |
| | 7.9 | Heat Sink..... | 81 |

- 7.10 Cover Design and Material Guidance 81
- 7.11 Gaskets 82
 - 7.11.1 Optical Isolation 83
 - 7.11.2 Dust Protection 84
- 7.12 Firmware Recovery 84
- 7.13 Calibration Support 85
- 7.14 Multi-Camera Hardware Sync 85
- 7.15 Handling Conditions 86
- 8 Platform Design Guidelines 87
 - 8.1 Vision Processor D4 on Motherboard 87
 - 8.2 Kaby Lake U and Kaby Lake Y platforms 88
 - 8.2.1 Kaby Lake Platform Introduction..... 88
 - 8.2.2 Supported PCB Stack-Up and Routing Geometries 88
 - 8.2.3 Vision Processor D4 on Motherboard with USB Host Interface..... 89
 - 8.2.4 Vision Processor D4 on Motherboard with MIPI Host Interface 90
 - 8.2.5 Vision Processor D4 Board for Integrated Peripheral (USB 3.1 Gen 1 Host to Vision Processor D4 Routing) 92
 - 8.2.6 USB2.0 Design Guidelines (USB2 Host to Vision Processor D4 Routing) 93
 - 8.3 Cherry Trail T4 Platform..... 94
 - 8.3.1 Cherry Trail T4 Platform Introduction 94
 - 8.3.2 Vision Processor D4 Platform Design Guidelines..... 94
- 9 Regulatory Compliance 95
 - 9.1 System Laser Compliance 95
 - 9.1.1 Certification Statement..... 95
 - 9.1.2 Explanatory Label 95
 - 9.1.3 Cautionary Statements..... 95
 - 9.1.4 Manufacturer’s Information 96
 - 9.1.5 US FDA Accession Number 96
 - 9.1.6 NRTL Statement 96
 - 9.2 Ecology Compliance 97
 - 9.2.1 China RoHS Declaration..... 97
 - 9.2.2 Waste Electrical and Electronic Equipment (WEEE)..... 98
- 10 Mechanical Drawings 99
- 11 Connector Drawings 107
- 12 Appendix A – Vision Processor D4 on Motherboard Schematic Checklist 109
 - 12.1 Power Delivery 116
- 13 Appendix B- Cover Material 119

Figures

- Figure 2-1. Active Infrared (IR) Stereo Vision Technology 14
- Figure 2-2. Depth Measurement (Z) versus Range (R)..... 14
- Figure 2-3. Vision Processor D4 Camera System Block Diagram 15
- Figure 3-1. Vision Processor D4 Package Drawing 26
- Figure 3-2. Vision Processor D4 Ball-out 27

| | |
|--|-----|
| Figure 3-3. Vision Processor D4 Power Sequencing | 31 |
| Figure 3-4. Stereo Depth Module (Intel® RealSense™ Depth Module D410)..... | 33 |
| Figure 3-5. Stereo Depth Module (Intel® RealSense™ Depth Module D430)..... | 33 |
| Figure 3-6. Stereo Depth Module Power Sequence | 40 |
| Figure 3-7. Vision Processor D4 Board (USB Peripheral Type-C)..... | 41 |
| Figure 3-8. Flex Interposer (Illustration)..... | 43 |
| Figure 3-9. Rigid Interposer (Illustration) | 43 |
| Figure 3-10. Depth Module Receptacle and Plug Connector Pin Position | 44 |
| Figure 3-11. Depth Module Connector Orientation and Pin Position..... | 46 |
| Figure 3-12. USB Type-C Receptacle Pin Map | 48 |
| Figure 3-13. Intel® RealSense™ Depth Camera D415..... | 50 |
| Figure 3-14. Intel® RealSense™ Depth Camera D435/D435i | 51 |
| Figure 4-1. Depth Field of View to Depth Map illustration | 58 |
| Figure 4-2. Left Invalid Depth Band | 59 |
| Figure 4-3. Depth Module Depth Start Point Reference | 63 |
| Figure 4-4. Depth Camera Depth Start Point Reference | 64 |
| Figure 4-5. Depth Module X-Y Depth Origin Reference..... | 65 |
| Figure 4-6. Depth Camera X-Y Depth Origin Reference..... | 66 |
| Figure 7-1. System Block Diagram..... | 71 |
| Figure 7-2. Intel® RealSense™ Vision Processor D4 Board | 72 |
| Figure 7-3. Vision Processor D4 on Motherboard (Illustration) | 72 |
| Figure 7-4. D4 Camera System Power Scheme..... | 73 |
| Figure 7-5. Host Motherboard USB 3.1 Gen 1 Routing | 75 |
| Figure 7-6. Receptacle Ground Bar Motherboard Connections..... | 76 |
| Figure 7-7. Bottom Stiffener Depth Module D410..... | 78 |
| Figure 7-8. Bottom Stiffener Depth Module D430..... | 78 |
| Figure 7-9. Stereo Depth Module Screw Mount | 79 |
| Figure 7-10. Stereo Depth Module Bracket..... | 79 |
| Figure 7-11. Stereo Depth Module Bracket Mount | 80 |
| Figure 7-12. Stereo Depth Module Bracket Install | 80 |
| Figure 7-13. Stereo Depth Module Air Gap | 81 |
| Figure 7-14. Illustration of Gasket Placement and Cover Material..... | 83 |
| Figure 7-15. Example of Light Leakage Effects..... | 84 |
| Figure 7-16. Firmware Recovery Sequence | 85 |
| Figure 7-17. External Sensor Sync Connector Location on D4 Vision Processor D4 Board | 85 |
| Figure 7-18. External Sensor Sync Connector Location on Depth Camera D435/D435i..... | 86 |
| Figure 8-1. Vision Processor D4 with USB Host Interface | 87 |
| Figure 8-2. Vision Processor D4 with MIPI Host Interface..... | 87 |
| Figure 8-3. Vision Processor D4 on Board for USB Integrated Peripheral | 88 |
| Figure 8-4. Host Processor - Vision Processor D4 | 89 |
| Figure 8-5. Vision Processor D4 Transmit - Host Receive | 90 |
| Figure 8-6. Stereo Depth Transmit - Vision Processor D4 Receive | 91 |
| Figure 8-7. Flex Interposer PCB Stack-Up | 92 |
| Figure 8-8. USB 3.1 Gen 1 Host to Vision Processor D4 Topology..... | 92 |
| Figure 8-9. USB2.0 Host to Vision Processor D4..... | 93 |
| Figure 9-1. NRTL Certifications | 97 |
| Figure 10-1. Intel® RealSense™ Depth Module D400..... | 99 |
| Figure 10-2. Intel® RealSense™ Depth Module D410..... | 100 |
| Figure 10-3. Intel® RealSense™ Depth Module D415..... | 101 |
| Figure 10-4. Intel® RealSense™ Depth Module D420..... | 102 |
| Figure 10-5. Intel® RealSense™ Depth Module D430..... | 103 |
| Figure 10-6. Vision Processor D4 Board USB Type-C (Intel® RealSense™ Vision Processor D4 Board)..... | 104 |
| Figure 10-7. Intel® RealSense™ Depth Camera D415..... | 105 |
| Figure 10-8. Intel® RealSense™ Depth Camera D435/D435i | 106 |

Figure 11-1. Receptacle Mechanical Drawing (50 Pin Depth Module Receptacle).....107
 Figure 11-2. Plug Mechanical Drawing (50 pin Depth Module Plug).....108
 Figure 12-1. Vision Processor D4 Laser PWM Reference Platform Schematic116
 Figure 12-2. Vision Processor D4 24MHz Crystal Clock Reference Platform Schematic.....116
 Figure 12-3. DC-DC Reference Platform Schematic (3.3V, 1.8V, 0.9V).....117
 Figure 12-4. Vision Processor D4 VDD_PG and AVDD Reference Platform Schematic118

Tables

Table 2-1. Depth Module Product SKU Descriptions 16
 Table 2-2. Depth Camera Product SKU Descriptions 17
 Table 3-1. Component Descriptions..... 18
 Table 3-2. Vision Processor D4 Signal Descriptions 19
 Table 3-3. Hardware Straps 24
 Table 3-4. Vision Processor D4 Package Mechanical Attributes..... 25
 Table 3-5. Vision Processor D4 Ball-out by Signal Name 27
 Table 3-6. Vision Processor D4 Power Requirements 30
 Table 3-7. Vision Processor D4 Power Sequencing Timing Parameters 30
 Table 3-8. Vision Processor D4 SPEC Code 31
 Table 3-9. Vision Processor D4 Storage and Operating Conditions..... 31
 Table 3-10. Stereo Depth Module..... 32
 Table 3-11. Stereo Depth Module SKU Properties..... 33
 Table 3-12. Standard Left and Right Imager Properties 34
 Table 3-13. Wide Left and Right Imager Properties 34
 Table 3-14. Standard Infrared Projector Parameters 35
 Table 3-15. Wide Infrared Projector Parameters 35
 Table 3-16. Color Sensor Properties 36
 Table 3-17. Depth Module 50-pin Connector Plug Details 37
 Table 3-18. Stereo Depth Module Product Labeling 37
 Table 3-19. Stereo Depth Module Label Fields 37
 Table 3-20. Intel® RealSense™ Depth Module D400 Series Product Identifier Code and Product Material Code 38
 Table 3-21. Other Stereo Depth Module Components 38
 Table 3-22. Intel® RealSense™ Depth Module D400 Mechanical Dimensions 39
 Table 3-23. Intel® RealSense™ Depth Module D410 Mechanical Dimensions 39
 Table 3-24. Intel® RealSense™ Depth Module D415 Mechanical Dimensions 39
 Table 3-25. Intel® RealSense™ Depth Module D420 Mechanical Dimensions 39
 Table 3-26. Intel® RealSense™ Depth Module D430 Mechanical Dimensions 40
 Table 3-27. Stereo Depth Module Storage and Operating Conditions 40
 Table 3-28. Vision Processor D4 Board 41
 Table 3-29. Vision Processor D4 Board Components 41
 Table 3-30. Vision Processor D4 USB Type-C Board Mechanical Dimensions 42
 Table 3-31. Depth Module Receptacle Details 42
 Table 3-32. Interposer Interconnect Signal Description..... 44
 Table 3-33. Custom Flex Interposer Ordering Logistics 46
 Table 3-34. External Sensor Connector Details 47
 Table 3-35. External Sensor Sync Connector Pin List 47
 Table 3-36. USB Peripheral Connector Pin List 48
 Table 3-37. Custom USB Type C cable Assemblies Ordering Logistics 49
 Table 3-38. ISP Properties 49
 Table 3-39. Vision Processor D4 Board Power Requirements 49
 Table 3-40. Vision Processor D4 Board Storage and Operating Conditions..... 50
 Table 3-41. Vision Processor D4 Board Product Identifier and Material Code..... 50

| | |
|--|-----|
| Table 3-42. Depth Camera SKU properties | 51 |
| Table 3-43. Intel® RealSense™ Depth Camera D415 Mechanical Dimensions..... | 51 |
| Table 3-44. Intel® RealSense™ Depth Camera D435, D435i Mechanical Dimensions | 52 |
| Table 3-45. Max Skin Temperature | 52 |
| Table 3-46. Depth Camera D400 Series Storage and Operating Conditions | 52 |
| Table 3-47. Depth Camera D400 Series Product Identifier and Material Code | 53 |
| Table 4-1. Vendor ID and Device ID Table | 54 |
| Table 4-2. Image Formats (USB 3.1 Gen1) | 54 |
| Table 4-3. Image Formats (USB 2.0)..... | 55 |
| Table 4-4. Simultaneous Image Streams (USB 3.1 Gen1 & USB2.0)..... | 56 |
| Table 4-5. Depth Field of View..... | 57 |
| Table 4-6. Minimum-Z Depth | 60 |
| Table 4-7: Depth Quality Metric..... | 60 |
| Table 4-8: Depth Quality Metric Illustration..... | 61 |
| Table 4-9. Depth Quality Specification | 61 |
| Table 4-10. Power- Ubuntu 16.04 | 62 |
| Table 4-11. Power – Windows 10 (RS4)..... | 62 |
| Table 4-12. Depth Module Depth Start Point | 63 |
| Table 4-13. Depth Cameras Depth Start Point | 64 |
| Table 4-14. Depth Module X-Y Depth Origin Coordinates..... | 65 |
| Table 4-15. Depth Camera X-Y Depth Origin Coordinates..... | 66 |
| Table 4-16. Depth Camera Controls | 66 |
| Table 4-17. RGB Exposed Controls | 67 |
| Table 4-18. IMU Specifications | 68 |
| Table 7-1. USB 3.1 Gen 1 Receptacle Characteristics..... | 74 |
| Table 7-2. USB 3.1 Gen 1 Receptacle Pin Out | 74 |
| Table 7-3. USB 3.1 Gen 1 Plug Characteristics..... | 74 |
| Table 7-4. Cable Assembly Specification | 75 |
| Table 7-5. Motherboard Receptacle Properties | 76 |
| Table 7-6. Vision Processor D4 Board as Embedded Peripheral Power Requirements | 76 |
| Table 7-7. Vision Processor D4 Board – Component Power and TDP at Max Operating Mode ⁽¹⁾ | 77 |
| Table 7-8. Stereo Depth Module (Standard) – Component Power and TDP at Max Operating Mode ⁽¹⁾ | 77 |
| Table 7-9. Stereo Depth Module (Wide) – Component Power and TDP at Max Operating Mode ⁽¹⁾ | 77 |
| Table 7-10. Vision Processor D4 Board Components – Case Temperature Limits (Still Air) | 77 |
| Table 7-11. Bracket Ordering Logistics | 80 |
| Table 7-12. Component Transmission..... | 82 |
| Table 7-13. Electrostatic Discharge Caution | 86 |
| Table 8-1. Host Transmit – Vision Processor D4 Receive Routing Guidelines | 89 |
| Table 8-2. Vision Processor D4 Transmit - Host Receive Routing Guidelines | 89 |
| Table 8-3. Vision Processor D4 Transmit – Host Receive Routing Guidelines..... | 90 |
| Table 8-4. Stereo Depth Module Transmit - Vision Processor D4 Receive Routing Guidelines | 91 |
| Table 8-5. USB 3.1 Gen 1 Host to Vision Processor D4 Routing Guidelines | 93 |
| Table 9-1. U.S. FDA Accession Number..... | 96 |
| Table 12-1. Vision Processor D4 on Motherboard Schematic Checklist | 109 |
| Table 12-2. Vision Processor D4 Decoupling and Filter Requirements | 118 |
| Table 13-1. Example: Cover Material Parameters..... | 119 |

Revision History

| Document Number | Revision Number | Description | Revision Date |
|-----------------|-----------------|---|---------------|
| 337029 | 001 | Initial release | January 2018 |
| | 002 | Tracking Module 1 removal, NRTL certification, 7.2.2.1 Firmware Update | March 2018 |
| | 003 | <ul style="list-style-type: none"> • Added USB2.0 support • Removed VBUS0 from Table 3 6. Vision Processor D4 Power Requirements • Table 3 12. Standard Left and Right Imager Properties • Table 3 13. Wide Left and Right Imager Properties • Table 3 9. Vision Processor D4 Storage and Operating Conditions • Table 3 27 Stereo Depth Module Storage and Operating Conditions • Table 3 38. Vision Processor D4 Board Storage and Operating Conditions • Table 3 44. Depth Camera D400 Series Storage and Operating Conditions • Table 4 3. Image Formats (USB 2.0) • Table 4 5. Simultaneous Image Streams (USB3.1 Gen1, USB 2.0) • 4.7 Depth Origin Point (Ground Truth Zero) • 7.14 Multi-Camera hardware sync for multi-camera configuration | July 2018 |

| Document Number | Revision Number | Description | Revision Date |
|-----------------|-----------------|---|---------------|
| | 004 | <ul style="list-style-type: none"> •Description and Features •Terminology •Table 2-2. Depth Camera Product SKU Descriptions •Table 3-11. Stereo Depth Module SKU Properties •Table 3-33. Custom Flex Interposer Ordering Logistics •Table 3-35. External Sensor Sync Connector Pin List •Table 3-42. Depth Camera SKU properties •Table 3-47. Depth Camera D400 Series Product Identifier and Material Code •Table 4-1. Vendor ID and Device ID Table •Table 4-2. Image Formats (USB 3.1 Gen1) •Table 4-3. Image Formats (USB 2.0) •Table 4-9. Depth Quality Specification •Section 4-12 IMU Specification | November 2018 |
| | 005 | <ul style="list-style-type: none"> •Table 3-11. Stereo Depth Module SKU Properties •Table 3-42. Depth Camera SKU Properties •Table 4-4. Simultaneous Image Streams (USB 3.1 Gen 1 & USB 2.0) •Table 4-18. IMU Specifications | January 2019 |

§ §

1 Description and Features

| | |
|--|---|
| <p>Description</p> <p>The Intel® RealSense™ D400 series is a stereo vision depth camera system. The subsystem assembly contains stereo depth module and vision processor with USB 2.0/USB 3.1 Gen 1 or MIPI¹ connection to host processor.</p> <p>The small size and ease of integration of the camera sub system provides system integrators flexibility to design into a wide range of products.</p> <p>The Intel® RealSense™ D400 series also offers complete depth cameras integrating vision processor, stereo depth module, RGB sensor with color image signal processing and Inertial Measurement Unit² (IMU). The depth cameras are designed for easy setup and portability making them ideal for makers, educators, hardware prototypes and software development.</p> <p>The Intel® RealSense™ D400 series is supported with cross-platform and open source Intel® RealSense™ SDK 2.0</p> <p>Features</p> <ul style="list-style-type: none"> • 2nd Generation Stereo Depth Camera System • 2nd Generation dedicated Intel® RealSense™ Vision Processor D4 with advanced algorithms • Infrared (IR) Laser Projector System (Class 1) • Full HD resolution Image sensors • Active Power Management • Selection of Stereo Depth Module options to meet your usage requirements <ol style="list-style-type: none"> 1. MIPI is not currently supported. Please contact your Intel representative on MIPI enablement timelines. 2. Camera SKU dependent | <p>Usages/Markets</p> <ul style="list-style-type: none"> • Drones • Robots • Home and Surveillance • Virtual Reality • PC Peripherals <p>Minimum System Requirements</p> <p>USB 2.0/USB 3.1 Gen 1 Ubuntu*16.xx/Windows*10</p> <p>Intel® RealSense™ Depth Camera D415 Features</p> <ul style="list-style-type: none"> • Intel® RealSense™ Vision Processor D4 • Up to 1280x720 active stereo depth resolution • Up to 1920x1080 RGB resolution • Depth Diagonal Field of View over 70° • Dual rolling shutter sensors for up to 90 FPS depth streaming • Range 0.3m to over 10m (Varies with lighting conditions) <p>Intel® RealSense™ Depth Camera D435/D435i Features</p> <ul style="list-style-type: none"> • Intel® RealSense™ Vision Processor D4 • Up to 1280x720 active stereo depth resolution • Up to 1920x1080 RGB resolution • Depth Diagonal Field of View over 90° • Dual global shutter sensors for up to 90 FPS depth streaming • Range 0.2m to over 10m (Varies with lighting conditions) • Intel® RealSense™ Depth Camera D435i includes Inertial Measurement Unit (IMU) for 6 degrees of freedom (6DoF) data |
|--|---|



2 Introduction

2.1 Purpose and Scope of this Document

This document captures the specifications and the design-in details for the Intel® RealSense™ D400 series family of products. This document provides information necessary to understand and implement an Intel® RealSense™ D400 series based camera system.

Note: Intel® RealSense™ D400 series is alternately referred as “D4 Camera System” in this document. Intel® RealSense™ Vision Processor D4 is alternately referred as “D4” in this document.

2.2 Terminology

| Term | Description |
|-----------------------|--|
| 6DOF | Six degrees of freedom (6DoF) refers to the freedom of movement of a rigid body in three-dimensional space. Forward/back, up/down, left/right, pitch, yaw, roll |
| Stereo Depth Baseline | The distance between the center of the left and right imagers in a stereo camera |
| MIPI CSI-2 | The Camera Serial Interface (CSI) is a specification of the Mobile Industry Processor Interface (MIPI) Alliance and CSI-2 is the 2 nd generation specification defining the interface between a camera and a host processor |
| Depth | Depth video streams are like color video streams except each pixel has a value representing the distance away from the camera instead of color information |
| D4 (DS5) | If the term D4 is used alone, it refers to the entire D4 camera system consisting of various modules and components. If the term D4 is used with an appropriate qualifier (i.e. D4 Vision Processor, D4 Vision Processor Board), it refers to the specific module or component within the D4 camera system. |
| FOV | Field Of View (FOV) describes the angular extent of a given scene that is imaged by a camera. A camera's FOV can be measured horizontally, vertically, or diagonally |
| Host System | Computer or SOC connected to D4 camera |
| I2C | I ² C (Inter-Integrated Circuit), pronounced I-squared-C, is a multi-master, multi-slave, single-ended, serial computer bus invented by Philips Semiconductor (now NXP Semiconductors). It is typically used to allow easy control and data communication between components. |
| IR Projector | This refers to the source of infrared (IR) light used for illuminating a scene, object, or person to collect depth data. |

| Term | Description |
|------------------------------|---|
| Imagers | Depth camera system uses a pair of cameras referred as imagers to calculate depth. They are identical cameras configured with identical settings. |
| Image Signal Processor (ISP) | Image processing functions to enhance color image quality |
| Left imager | From the perspective of the stereo camera looking out at the world, the left imager is on the left side of the camera module. Thus, when the user is facing the D4 camera, the left imager is actually on the right side of the camera module. |
| Lens | This refers to the optical component of an imager in the D4 camera. Its purpose is to focus the incoming light rays onto the CMOS chip in the imager. |
| MIPI | MIPI (Mobile Industry Processor Interface) is a global, open membership organization that develops interface specifications for the mobile ecosystem |
| Platform camera | This refers to the two-dimensional (2D) color camera on platform |
| System On Chip (SoC) | Integrated circuit (IC) that integrates all components of a computer |
| Stereo Depth Module | This refers to a stiffened module containing at least two imagers. The distance between the imagers, which is referred to as the baseline or intraocular spacing, is typically in the range of 20 mm to 70 mm. |
| Stereo camera | This refers to a pair of imagers looking at the same subject from slightly different perspectives. The difference in the perspectives is used to generate a depth map by calculating a numeric value for the distance from the imagers to every point in the scene. |
| SKU | Stock Keeping Unit (SKU) is a unique identifier for distinct products. It is often used in the scope of naming different versions of a device |
| TBD | To Be Determined. In the context of this document, information will be available in a later revision. |

2.3 Stereo Vision Depth Technology Overview

The Intel® RealSense™ D400 series depth camera uses stereo vision to calculate depth. The stereo vision implementation consists of a left imager, right imager, and an optional infrared projector. The infrared projector projects non-visible static IR pattern to improve depth accuracy in scenes with low texture. The left and right imagers capture the scene and sends imager data to the depth imaging (vision) processor, which calculates depth values for each pixel in the image by correlating points on the left image to the right image and via shift between a point on the Left image and the Right image. The depth pixel values are processed to generate a depth frame. Subsequent depth frames create a depth video stream.

Figure 2-1. Active Infrared (IR) Stereo Vision Technology

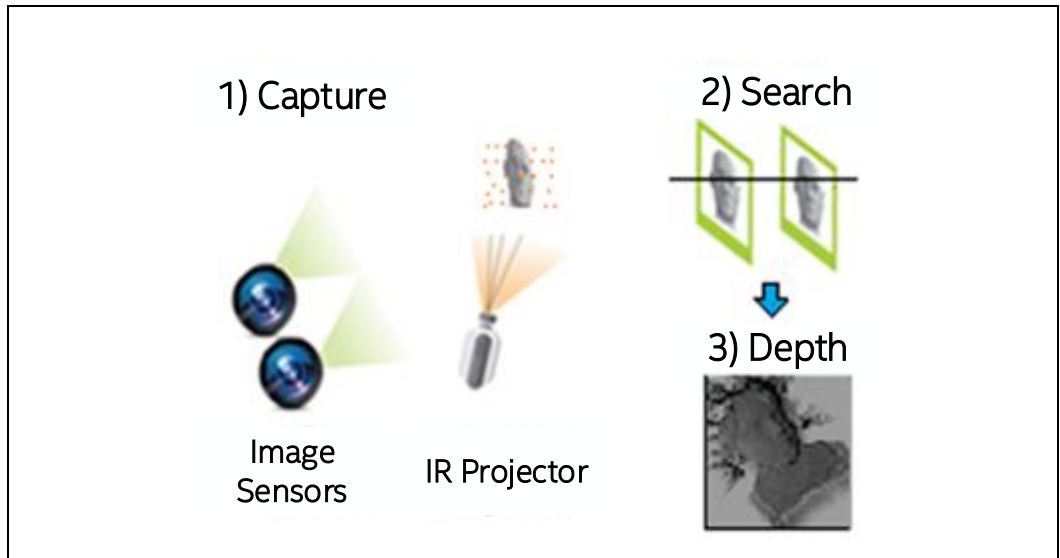

The depth pixel value is a measurement from the parallel plane of the imagers and not the absolute range as illustrated.

Figure 2-2. Depth Measurement (Z) versus Range (R)

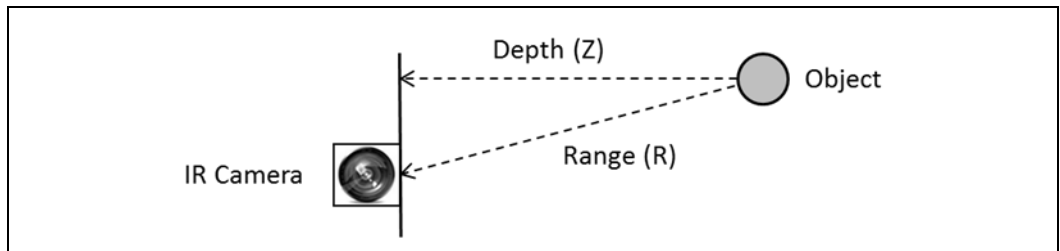

2.4 Camera System Block Diagram

The camera system has two main components, Vision processor D4 and Depth module. The Vision processor D4 is either on the host processor motherboard or on a discrete board with either USB2.0/USB 3.1 Gen1 or MIPI connection to the host processor. The Depth module incorporates left and right imagers for stereo vision with the optional IR projector and RGB color sensor. The RGB color sensor data is sent to vision processor D4 via the color Image Signal Processor (ISP) on Host Processor motherboard or D4 Board.

Figure 2-3. Vision Processor D4 Camera System Block Diagram

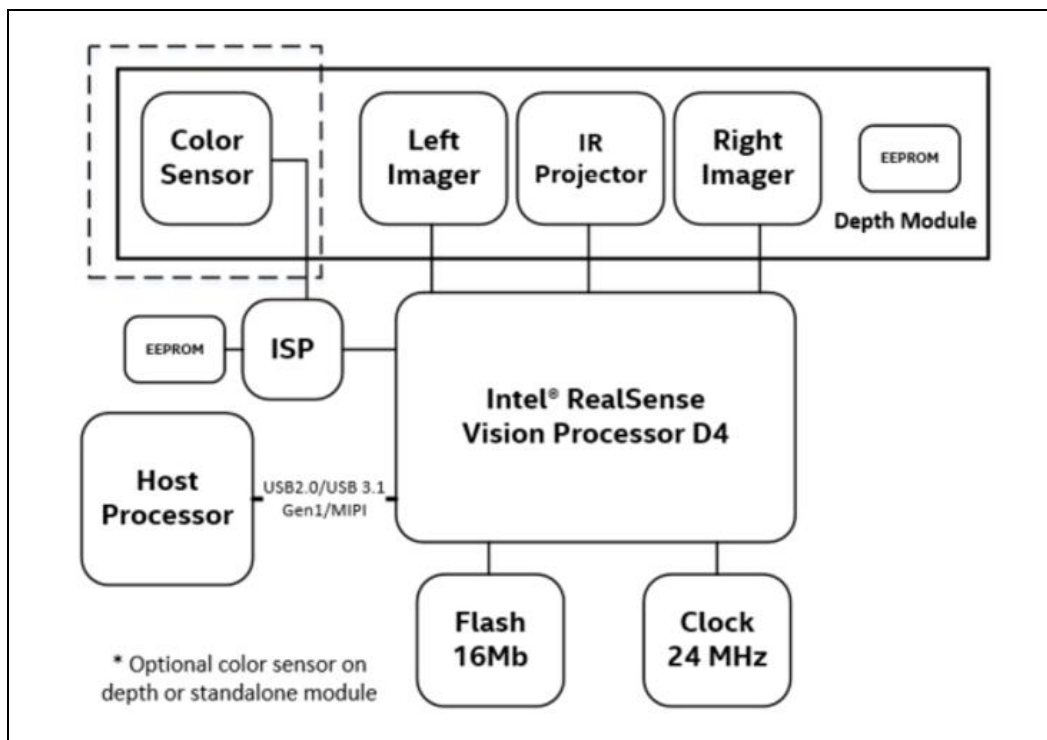

2.5 Intel® RealSense™ Depth Module D400 series Product SKUs

Table below describes main components that make up the different depth module SKUs

Table 2-1. Depth Module Product SKU Descriptions

| Component | Subcomponent | D400 | D410 | D415 | D420 | D430 |
|---------------------------------------|-----------------------------|------|------|------|------|------|
| Intel® RealSense™ Vision Processor D4 | - | ✓ | ✓ | ✓ | ✓ | ✓ |
| Intel® RealSense™ Depth Module | Standard Stereo Imagers | ✓ | ✓ | ✓ | X | X |
| | Wide Stereo Imagers | X | X | X | ✓ | ✓ |
| | Standard Infrared Projector | X | ✓ | ✓ | X | X |
| | Wide Infrared Projector | X | X | X | X | ✓ |
| | RGB color sensor | X | X | ✓ | X | X |

D400 - Intel® RealSense™ Depth Module D400
D410 - Intel® RealSense™ Depth Module D410
D415 - Intel® RealSense™ Depth Module D415
D420 - Intel® RealSense™ Depth Module D420
D430 - Intel® RealSense™ Depth Module D430

2.6 Intel® RealSense™ Depth Camera D400 series Product SKUs

Table below describes main components that make up the different camera SKUs:

Table 2-2. Depth Camera Product SKU Descriptions

| Component | Subcomponent | Intel® RealSense™ Depth Camera D415 | Intel® RealSense™ Depth Camera D435 | Intel® RealSense™ Depth Camera D435i |
|---------------------------------------|-----------------------------|-------------------------------------|-------------------------------------|--------------------------------------|
| Intel® RealSense™ Vision Processor D4 | - | ✓ | ✓ | ✓ |
| Intel® RealSense™ Depth Module | Standard Stereo Imagers | ✓ | x | x |
| | Wide Stereo Imagers | x | ✓ | ✓ |
| | Standard Infrared Projector | ✓ | x | x |
| | Wide Infrared Projector | x | ✓ | ✓ |
| | RGB color sensor | ✓ | ✓ | ✓ |
| Inertial Measurement Unit (IMU) | | x | x | ✓ |



3 Component Specification

3.1 Vision Processor D4 Camera System Components

Table 3-1. Component Descriptions

| Component | Description |
|---------------------------------------|--|
| Host Processor | Host Processor that receives Depth and other data streams from Vision Processor D4 |
| Vision Processor D4 (DS5 ASIC) | Depth Imaging Processor with USB 2.0/USB 3.1 Gen 1 or MIPI interface connection to Host Processor |
| Clock | 24MHz clock source for Vision Processor D4 |
| Serial Flash Memory | SPI 16Mb Serial Flash memory for firmware storage |
| Stereo Depth Module | Camera module with left and Right Imager, Color Sensor†, IR projector† enclosed in a stiffener |
| Power Delivery | Circuitry on motherboard/Vision processor D4 Board to deliver and manage power to Vision Processor D4 and Stereo Depth Module. |
| Stereo Depth Connector and Interposer | 50 pin connector on motherboard/Vision Processor D4 Board and Stereo Depth module with interposer for connection |

(†) SKU dependent

3.2 Host Processor

The host processor interface to Vision Processor D4 is either USB 2.0/USB 3.1 Gen 1 or MIPI. To ensure the best of quality of service, the Vision Processor D4 must be connected to a dedicated USB 3.1 Gen 1 root port within the host processor system.

3.3 Intel® RealSense™ Vision Processor D4

The primary function of Vision Processor D4 is to perform depth stereo vision processing. The Vision Processor D4 on Host Processor motherboard or on Vision Processor D4 Board communicates to the host processor through USB2.0/USB 3.1 Gen 1 or MIPI and receives sensor data from stereo depth module. The Vision Processor D4 supports MIPI CSI-2 channels for connection to image sensors.

3.3.1 Vision Processor D4 Features

- 28nm Process Technology.

- 5 MIPI camera ports with each MIPI lane capable of handling data transfers of up to 750 Mbps.
- USB2.0/USB 3.1 Gen 1 or MIPI interface to host system.
- Image rectification for camera optics and alignment compensation
- IR Projector (Laser) controls
- Serial Peripheral Interface for fast data transfer with external SPI flash.
- Integrated I2C ports
- General purpose Input Output pins
- Active power gating

3.3.2 Vision Processor D4 Signal Description

Table 3-2. Vision Processor D4 Signal Descriptions

RESERVED – Signal reserved for future usage

IO Type- Input Output Buffer type

A – Analog

I – Input

O - Output

| Signal Name | Description | IO Type | After RESET |
|----------------------|---|---------|-------------|
| Host MIPI | | | |
| H_DATAP0 H_DATAN0 | Host MIPI Data Lane 0 Differential Pair | A | I |
| H_DATAP1 H_DATAN1 | Host MIPI Data Lane 1 Differential Pair | A | I |
| H_DATAP2 H_DATAN2 | Host MIPI Data Lane 2 Differential Pair | A | I |
| H_DATAP3 H_DATAN3 | Host MIPI Data Lane 3 Differential Pair | A | I |
| H_CLKP H_CLKN | Host MIPI Clock Differential Transmit Pair | A | I |
| H_SDA H_SCL | Host I2C Bus Data and Clock | I/O | IO |
| H_REXT | Host MIPI External Reference 6.04K 1% resistor pull down to ground) | A | I |
| Imager A MIPI | | | |
| A_DATAP0 A_DATAN0 | Imager A MIPI Data Lane 0 Differential Receive Pair | A | I |
| A_DATAP1 A_DATAN1 | Imager A MIPI Data Lane 1 Differential Receive Pair | A | I |

| Signal Name | Description | IO Type | After RESET |
|----------------------|--|---------|-------------|
| A_CLKP A_CKLN | Imager A MIPI Clock Differential Receive Pair | A | I |
| A_SDA A_SCL | Imager A I2C Bus Data and Clock | I/O | IO |
| A_RCLK | Imager A Reference Clock | I/O | O |
| A_PDOWN | (RESERVED) Imager A Power Down Signal | I/O | O |
| A_VSYNC | Imager A Vertical/Frame Sync | I/O | I |
| A_RESETN | Imager A Reset | I/O | O |
| A_REXT | Imager A MIPI External Reference (6.04K 1% resistor pull down to ground) | A | I |
| Imager B MIPI | | | |
| B_DATAP0 B_DATAN0 | (RESERVED) Imager B MIPI Data Lane 0 Differential Receive Pair | A | I |
| B_DATAP1 B_DATAN1 | (RESERVED) Imager B MIPI Data Lane 1 Differential Receive Pair | A | I |
| B_CLKP B_CKLN | (RESERVED) Imager B MIPI Clock Differential Receive Pair | A | I |
| B_SDA B_SCL | (RESERVED) Imager B I2C Bus Data and Clock | I/O | IO |
| B_RCLK | (RESERVED) Imager B Reference Clock | I/O | O |
| B_PDOWN | (RESERVED) Imager B Power Down | I/O | O |
| B_VSYNC | (RESERVED) Imager B Vertical/Frame Sync | I/O | I |
| B_RESETN | (RESERVED) Imager B Reset | I/O | O |
| B_REXT | Imager B MIPI External Reference (6.04K 1% resistor pull down to ground) | A | I |
| Imager M MIPI | | | |
| M_DATAP0 M_DATAN0 | Imager M MIPI Data Lane 0 Differential Receive Pair | A | I |
| M_DATAP1 M_DATAN1 | Imager M MIPI Data Lane 1 Differential Receive Pair | A | I |
| M_CLKP M_CKLN | Imager M MIPI Clock Differential Receive Pair | A | I |
| M_SDA M_SCL | Imager M I2C Bus Data and Clock | I/O | IO |
| M_RCLK | Imager M Reference Clock | I/O | O |
| M_PDOWN | (RESERVED) Imager M Power Down | I/O | O |
| M_VSYNC | Imager M Vertical/Frame Sync | I/O | I |

| Signal Name | Description | IO Type | After RESET |
|---|--|---------|-------------|
| M_RESETN | Imager M Reset | I/O | O |
| M_REXT | Imager M MIPI External Reference (6.04K 1% resistor pull down to ground) | A | I |
| Imager Y MIPI | | | |
| Y_DATAP0 Y_DATAN0 | Imager Y MIPI Data Lane 0 Differential Receive Pair | A | I |
| Y_DATAP1 Y_DATAN1 | Imager Y MIPI Data Lane 1 Differential Receive Pair | A | I |
| Y_CLKP Y_CKLN | Imager Y MIPI Clock Differential Receive Pair | A | I |
| Y_SDA Y_SCL | Imager Y I2C Bus Data and Clock | I/O | IO |
| Y_RCLK | Imager Y Reference Clock | I/O | O |
| Y_PDOWN | (RESERVED) Imager Y Power Down | I/O | O |
| Y_VSYNC | Imager Y Vertical/Frame Sync | I/O | I |
| Y_RESETN | Imager Y Reset | I/O | O |
| Y_REXT | Imager Y MIPI External Reference (6.04K 1% resistor pull down to ground) | A | I |
| Imager Z MIPI | | | |
| Z_DATAP0 Z_DATAN0 | (RESERVED) Imager Z MIPI Data Lane 0 Differential Receive Pair | A | I |
| Z_DATAP1 Z_DATAN1 | (RESERVED) Imager Z MIPI Data Lane 1 Differential Receive Pair | A | I |
| Z_CLKP Z_CKLN | (RESERVED) Imager Z MIPI Clock differential Receive Pair | A | I |
| Z_SDA Z_SCL | (RESERVED) Imager Z I2C Bus Data and Clock | I/O | IO |
| Z_RCLK | (RESERVED) Imager Z Reference Clock | I/O | O |
| Z_PDOWN | (RESERVED) Imager Z Power Down | I/O | O |
| Z_VSYNC | Depth Vertical/Frame Sync | I/O | O |
| Z_RESETN | (RESERVED) Imager Z Reset | I/O | O |
| Z_REXT | Imager Z MIPI External Reference (6.04K 1% resistor pull down to ground) | A | I |
| Serial Peripheral Interconnect (SPI) | | | |
| SPI_DI | SPI Data Input | I/O | I |
| SPI_DO | SPI Data Output | I/O | O |
| SPI_CLK | SPI Clock | O | O |

| Signal Name | Description | IO Type | After RESET |
|--|--|---------|-------------|
| SPI_CS | SPI Chip Select | O | O |
| SPI_WP | Flash Write Protect | O | O |
| General Purpose Input Output (GPIO) | | | |
| GPIO[0] | (RESERVED) Not Defined | I/O | I |
| GPIO[1] | (RESERVED) Not Defined | I/O | I |
| GPIO[2] | Laser PWM – Controls Laser Power for IR projector on Stereo Module | I/O | O |
| GPIO[3] | (RESERVED) Not Defined | I/O | I |
| GPIO[4] | (RESERVED) Not Defined | I/O | I |
| GPIO[5] | (RESERVED) Not Defined | I/O | I |
| GPIO[6] | (RESERVED) Not Defined | I/O | I |
| GPIO[7] | (RESERVED) Not Defined | I/O | I/O |
| EGPIO[0] | (RESERVED) Not Defined | I/O | I/O |
| EGPIO[1] | (RESERVED) Not Defined | I/O | I/O |
| EGPIO[2] | (RESERVED) Not Defined | I/O | I/O |
| EGPIO[3] | Laser_PWRDN - IR projector Power Down Signal | I/O | O |
| EGPIO[4] | (RESERVED) Not Defined | I/O | I/O |
| EGPIO[5] | FLAGB – IR Projector Fault Detect | I/O | I |
| EGPIO[6] | (RESERVED) Not Defined | I/O | I/O |
| EGPIO[7] | (RESERVED) Not Defined | I/O | I/O |
| EGPIO[8] | ISP_FCS (Color ISP) | I/O | O |
| EGPIO[9] | (RESERVED) Not Defined | I/O | I/O |
| EGPIO[10] | (RESERVED) Not Defined | I/O | I/O |
| EGPIO[11] | (RESERVED) Not Defined | I/O | I/O |
| EGPIO[12] | (RESERVED) Not Defined | I/O | I/O |
| EGPIO[13] | (RESERVED) - For Intel test purpose only | I/O | I/O |
| Miscellaneous | | | |
| LD_ON_OUT_XX | (RESERVED) Laser Enable | O | O |
| MODSTROB | (RESERVED) Modulation current strobe | O | O |
| MODSIGN | (RESERVED) Modulation current sign | O | O |
| LD_ERR | Laser Error (Active High) | I | I |
| CLKXI | 24MHz XTAL | I | I |
| CLKXO | 24MHz XTAL | I | I |
| PRSTN | D4 Reset | I | I |
| CW_CSR_PRSTn | Hardware reset without debug port reset | I/O | I |

| Signal Name | Description | IO Type | After RESET |
|-------------------------|---|---------|-------------|
| PMU_PWR_EN | Switchable domain (VDD_PG) power control signal | I/O | O |
| DFU | Dynamic FW update, used for FW recovery | I/O | I |
| ISP_SCL ISP_SDA | I2C Bus Data and Clock | I/O | IO |
| VQPSQ | (RESERVED) – For Intel test purpose only | O | O |
| VQPSM | (RESERVED) – For Intel test purpose only | O | O |
| REFPADCLKP | (RESERVED) – For Intel test purpose only | I | I |
| REFPADCLKM | (RESERVED) – For Intel test purpose only | I | I |
| JTAG | | | |
| TDI | Test Data Input | I/O | I |
| TDO | Test Data Output | I/O | O |
| TCLK | Test Clock Input | I/O | I |
| TMS | Test Mode Select | I/O | I |
| TRSTN | Test Reset | I/O | I |
| USB | | | |
| USB_RXP | USB 3.1 Gen 1 receive, positive side | A | I |
| USB_RXN | USB 3.1 Gen 1 receive, negative side | A | I |
| USB_TXP | USB 3.1 Gen 1 Transmit, positive side | A | O |
| USB_TXN | USB 3.1 Gen 1 Transmit, negative side | A | O |
| USB_DP | USB 2.0 D+ line | A | IO |
| USB_DN | USB 2.0 D- line | A | IO |
| USB_ID | Mini-receptacle identifier and test point | | |
| USB_RESREF | Reference Resistor input. 200 Ohm 1% | A | I |
| Power and Ground | | | |
| VDD | 0.9V (Core Voltage) | Power | |
| VDD_PG | 0.9V (Switched Core Voltage) | Power | |
| USB_DVDD | 0.9V (USB Core Voltage) | Power | |
| VPTX0 | 0.9V (USB Core Voltage) | Power | |
| VP | 0.9V (USB Core Voltage) | Power | |
| *_AVDD | 1.8V (MIPI Core and IO Voltage) | Power | |
| VDDPLL | 0.9V (PLL Voltage) | Power | |
| VDDTS | 1.8V (Temperature Sensor Voltage) | Power | |
| VDDPST18 | 1.8V (IO Voltage) | Power | |
| USB_VDD330 | 3.3V (USB Core Voltage) | Power | |

| Signal Name | Description | IO Type | After RESET |
|-------------|---------------------------|---------|-------------|
| VBUS0 | 3.3V (VBUS power monitor) | Power | |
| VSS | Ground | GND | |
| *_AGND | Ground | GND | |

Table 3-3. Hardware Straps

| Pin | Boot Load | HW/FW | Description |
|----------|-----------|-------|--|
| EPGPIO0 | No | FW | USB connection type: 0: Peripheral (default) 1: Integrated |
| EGPIO4 | Yes | HW | SPI Interface: 0: SPI on "Z" 1: SPI connected (default) |
| EPGPIO7 | Yes | FW | Flash 00: 64Mbit 01: 8Mbit 10: 16 Mbit (default) 11: 32 Mbit |
| EPGPIO8 | | | |
| EPGPIO9 | No | FW | Host interface: 0: USB (default) 1: MIPI |
| EPGPIO10 | No | FW | Board version [0] (default: 0) |
| EPGPIO11 | No | FW | Board version [1] (default: 0) |
| EPGPIO12 | No | FW | Board version [2] (default: 0) |
| DFU | Yes | HW | Go to DFU 0: Disabled (default) 1: Go to DFU mode (Recovery) |

NOTES:

- Boot Load – Read during Boot
- Hardware (HW) Strap – External hardware pin state directly configures D4 functionality
- Firmware (FW) Strap – External hardware pin state is read by firmware and firmware configures D4 functionality

3.3.3 Vision Processor D4 Package Mechanical Attributes

Table below provides an overview of the mechanical attributes of the package.

Table 3-4. Vision Processor D4 Package Mechanical Attributes

| Pin | Boot Load | HW/FW |
|-----------------------|----------------------------------|-----------------------------------|
| Package Technology | Package Type | FlipChip CSP (Chip Scale Package) |
| | Interconnect | Ball Grid Array (BGA) Ball |
| | Lead Free | Yes |
| | Halogenated Flame Retardant Free | Yes |
| Package Configuration | Solder Ball Composition | SAC125Ni |
| | Ball/Pin Count | 225 solder balls |
| | Grid Array Pattern | 15 x 15 |
| Package Dimensions | Nominal Package Size (mm) | 6.40 x 6.40 |
| | Min Ball/Pin pitch (mm) | 0.42 |
| Weight | | ~1 gm |

Figure 3-1. Vision Processor D4 Package Drawing

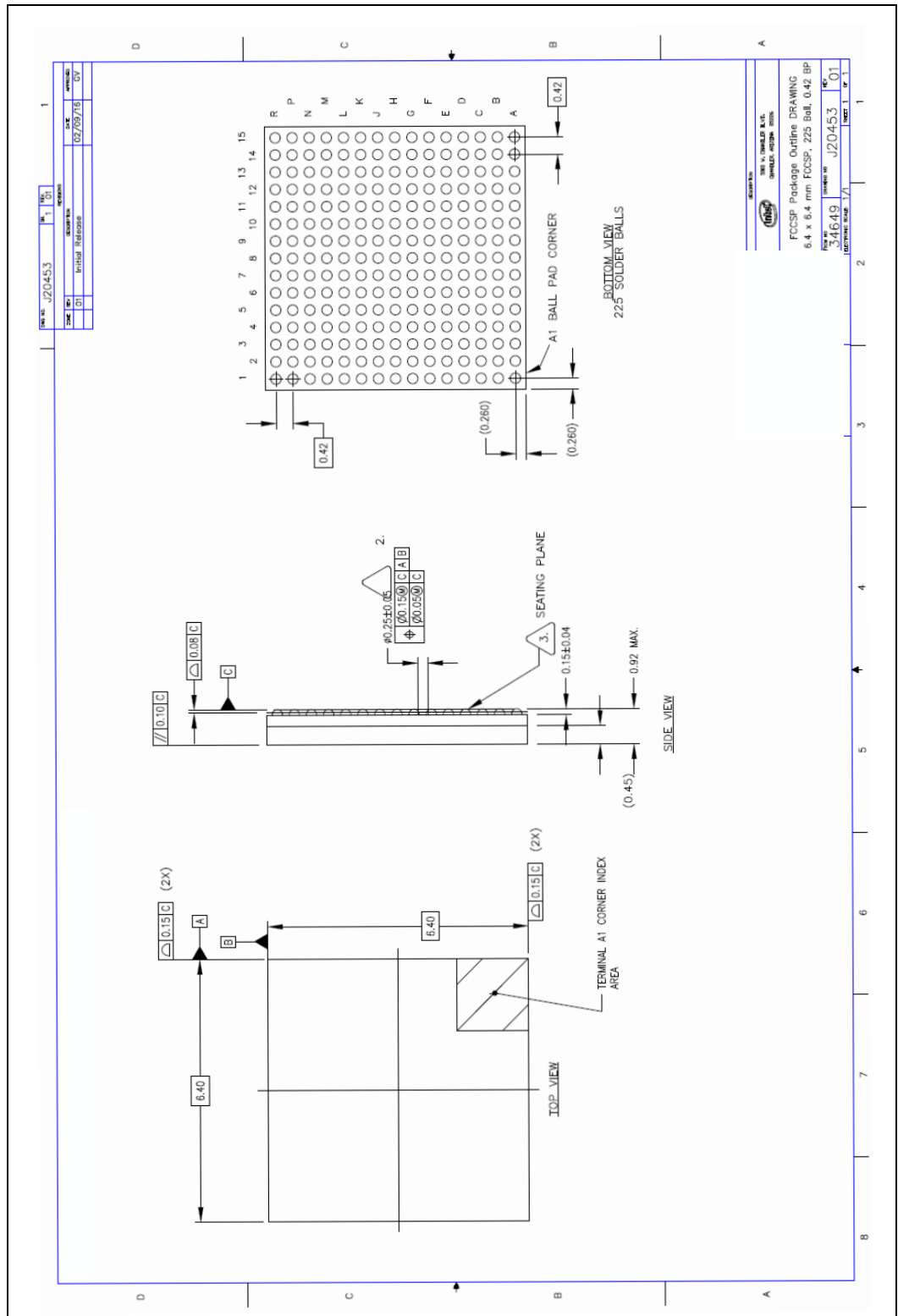

Figure 3-2. Vision Processor D4 Ball-out

| | A | B | C | D | E | F | G | H | J | K | L | M | N | P | R | |
|----|----------|----------|------------|------------|------------|----------|---------------|----------|----------------|---------------|---------|---------|----------|-------------|----------|----|
| 15 | VSS | Y_DATAN0 | Y_REXT | Y_SCL | GPIO_0 | GPIO_1 | GPIO_5 | GPIO_6 | MODSTROB | TMS | TRSTN | SPI_WPN | SPI_MISO | CW_CSR_RSTN | VSS | 15 |
| 14 | Y_CLKN | Y_CLKP | Y_DATAP0 | Y_RCLK | Y_SDA | Y_RESETN | GPIO_2 | GPIO_3 | MODSIGN | TCLK | TDO | SPI_CLK | SPI_MOSI | Z_RESETN | Z_VSYNC | 14 |
| 13 | Y_DATAN1 | Y_DATAP1 | VSS | VSS | Y_PDOWN | Y_VSYNC | GPIO_4 | GPIO_7 | LD_ERR | ID_ON_OUT_3V | TDI | SPI_CS | Z_SDA | Z_DATAP0 | Z_RCLK | 13 |
| 12 | B_DATAN0 | B_SCL | B_SDA | Y_AVDD | VSS | VSS | VDDPST18_LEFT | VSS | VSS | VDDPST18_LEFT | VSS | VSS | Z_SCL | Z_CLKP | Z_DATAN0 | 12 |
| 11 | B_CLKN | B_DATAP0 | B_REXT | VSS | VSS | VSS | VDD | VDD | VDD | VSS | VSS | Z_AVDD | Z_PDOWN | Z_DATAP1 | Z_CLKN | 11 |
| 10 | B_DATAN1 | B_CLKP | B_RESETN | B_AVDD | VDD_PG | VDD_PG | VDD_PG | VDD | VDD | VDD_PG | VDD_PG | ISP_SCL | Z_REXT | M_DATAP1 | Z_DATAN1 | 10 |
| 9 | H_DATAN3 | B_DATAP1 | B_PDOWN | VSS | VDD_PG | VDD_PG | VDD_PG | VSS | VSS | VDD_PG | VDD_PG | VSS | ISP_SDA | M_CLKP | M_DATAN1 | 9 |
| 8 | H_DATAN2 | H_DATAP3 | B_VSYNC | VSS | VSS | VDD_PG | VDD_PG | VSS | VSS | VSS | VSS | VSS | VSS | M_DATAP0 | M_CLKN | 8 |
| 7 | H_CLKN | H_DATAP2 | B_RCLK | H_AVDD | VSS | VSS | VSS | VSS | VSS | VDD_PG | VDD_PG | M_AVDD | M_RESETN | M_PDOWN | M_DATAN0 | 7 |
| 6 | H_DATAN1 | H_CLKP | H_AVDD | REFPADCLKP | REFPADCLKM | VSS | VDD | VDD | VSS | VDD_PG | VDD_PG | M_REXT | M_VSYNC | M_SDA | M_RCLK | 6 |
| 5 | H_DATAN0 | H_DATAP1 | H_REXT | VP | USB_ID | VDD | VDD | VDD | VSS | VSS | VSS | VSS | VSS | A_DATAP1 | M_SCL | 5 |
| 4 | H_SCL | H_DATAP0 | USB_VDD330 | VPTX0 | USB_RESREF | USB_DVDD | VSS | VSS | VDDPST18_RIGHT | VSS | VSS | A_AVDD | A_REXT | A_CLKP | A_DATAN1 | 4 |
| 3 | USB_RXN | H_SDA | PRSTN | USB_DP | EGPIO_1 | EGPIO_11 | VDDTS | VSSTS | VDDPST18_RIGHT | PMU_PWR_EN | VQPSQ | VQPSM | A_PDOWN | A_DATAP0 | A_CLKN | 3 |
| 2 | USB_TXN | USB_RXP | DFU | USB_DN | EGPIO_9 | EGPIO_13 | VDDPLL | VSSPLL | EGPIO_5 | EGPIO_12 | EGPIO_3 | EGPIO_4 | A_SCL | A_RCLK | A_DATAN0 | 2 |
| 1 | VSS | USB_TXP | VBUS0 | EGPIO_6 | EGPIO_7 | EGPIO_8 | CLK_XIN | CLK_XOUT | EGPIO_10 | EGPIO_2 | EGPIO_0 | A_VSYNC | A_SDA | A_RESETN | VSS | 1 |
| | A | B | C | D | E | F | G | H | J | K | L | M | N | P | R | |

Table 3-5. Vision Processor D4 Ball-out by Signal Name

| Ball | Name | Ball | Name | Ball | Name |
|------|----------|------|----------|------|------------|
| A01 | H_AGND | B01 | USB_TXP | C01 | VBUS0 |
| A02 | USB_TXN | B02 | USB_RXP | C02 | DFU |
| A03 | USB_RXN | B03 | H_SDA | C03 | PRSTN |
| A04 | H_SCL | B04 | H_DATAP0 | C04 | USB_VDD330 |
| A05 | H_DATAN0 | B05 | H_DATAP1 | C05 | H_REXT |
| A06 | H_DATAN1 | B06 | H_CLKP | C06 | H_AVDD |
| A07 | H_CLKN | B07 | H_DATAP2 | C07 | B_RCLK |

| Ball | Name | Ball | Name | Ball | Name |
|------|---------------|------|------------|------|----------------|
| A08 | H_DATAN2 | B08 | H_DATAP3 | C08 | B_VSYNC |
| A09 | H_DATAN3 | B09 | B_DATAP1 | C09 | B_PDOWN |
| A10 | B_DATAN1 | B10 | B_CLKP | C10 | B_RESETN |
| A11 | B_CLKN | B11 | B_DATAP0 | C11 | B_REXT |
| A12 | B_DATAN0 | B12 | B_SCL | C12 | B_SDA |
| A13 | Y_DATAN1 | B13 | Y_DATAP1 | C13 | Y_AGND |
| A14 | Y_CLKN | B14 | Y_CLKP | C14 | Y_DATAP0 |
| A15 | Y_AGND | B15 | Y_DATAN0 | C15 | Y_REXT |
| D01 | EGPIO_6 | E01 | EGPIO_7 | F01 | EGPIO_8 |
| D02 | USB_DN | E02 | EGPIO_9 | F02 | EGPIO_13 |
| D03 | USB_DP | E03 | EGPIO_1 | F03 | EGPIO_11 |
| D04 | VPTX0 | E04 | USB_RESREF | F04 | USB_DVDD |
| D05 | VP | E05 | USB_ID | F05 | VDD |
| D06 | REFPADCLKP | E06 | REFPADCLKM | F06 | VSS |
| D07 | H_AVDD | E07 | H_AGND | F07 | VSS |
| D08 | B_AGND | E08 | VSS | F08 | VDD_PG |
| D09 | B_AGND | E09 | VDD_PG | F09 | VDD_PG |
| D10 | B_AVDD | E10 | VDD_PG | F10 | VDD_PG |
| D11 | VSS | E11 | VSS | F11 | VSS |
| D12 | Y_AVDD | E12 | VSS | F12 | VSS |
| D13 | VSS | E13 | Y_PDOWN | F13 | Y_VSYNC |
| D14 | Y_RCLK | E14 | Y_SDA | F14 | Y_RESETN |
| D15 | Y_SCL | E15 | GPIO_0 | F15 | GPIO_1 |
| G01 | CLK_XIN | H01 | CLK_XOUT | J01 | EGPIO_10 |
| G02 | VDDPLL | H02 | VSSPLL | J02 | EGPIO_5 |
| G03 | VDDTS | H03 | VSSTS | J03 | VDDPST18_RIGHT |
| G04 | VSS | H04 | VSS | J04 | VDDPST18_RIGHT |
| G05 | VDD | H05 | VDD | J05 | VSS |
| G06 | VDD | H06 | VDD | J06 | VSS |
| G07 | VSS | H07 | VSS | J07 | VSS |
| G08 | VDD_PG | H08 | VSS | J08 | VSS |
| G09 | VDD_PG | H09 | VSS | J09 | VSS |
| G10 | VDD_PG | H10 | VDD | J10 | VDD |
| G11 | VDD | H11 | VDD | J11 | VDD |
| G12 | VDDPST18_LEFT | H12 | VSS | J12 | VSS |

| Ball | Name | Ball | Name | Ball | Name |
|------|---------------|------|-------------|------|----------|
| G13 | GPIO_4 | H13 | GPIO_7 | J13 | LD_ERR |
| G14 | GPIO_2 | H14 | GPIO_3 | J14 | MODSIGN |
| G15 | GPIO_5 | H15 | GPIO_6 | J15 | MODSTROB |
| K01 | EGPIO_2 | L01 | EGPIO_0 | M01 | A_VSYNC |
| K02 | EGPIO_12 | L02 | EGPIO_3 | M02 | EGPIO_4 |
| K03 | PMU_PWR_EN | L03 | VQPSQ | M03 | VQPSM |
| K04 | VSS | L04 | VSS | M04 | A_AVDD |
| K05 | VSS | L05 | VSS | M05 | VSS |
| K06 | VDD_PG | L06 | VDD_PG | M06 | M_REXT |
| K07 | VDD_PG | L07 | VDD_PG | M07 | M_AVDD |
| K08 | VSS | L08 | VSS | M08 | M_AGND |
| K09 | VDD_PG | L09 | VDD_PG | M09 | M_AGND |
| K10 | VDD_PG | L10 | VDD_PG | M10 | ISP_SCL |
| K11 | VSS | L11 | VSS | M11 | Z_AVDD |
| K12 | VDDPST18_LEFT | L12 | VSS | M12 | VSS |
| K13 | LD_ON_OUT_XX | L13 | TDI | M13 | SPI_CS |
| K14 | TCLK | L14 | TDO | M14 | SPI_CLK |
| K15 | TMS | L15 | TRSTN | M15 | SPI_WPN |
| N01 | A_SDA | P01 | A_RESETN | R01 | A_AGND |
| N02 | A_SCL | P02 | A_RCLK | R02 | A_DATAN0 |
| N03 | A_PDOWN | P03 | A_DATAP0 | R03 | A_CLKN |
| N04 | A_REXT | P04 | A_CLKP | R04 | A_DATAN1 |
| N05 | A_AGND | P05 | A_DATAP1 | R05 | M_SCL |
| N06 | M_VSYNC | P06 | M_SDA | R06 | M_RCLK |
| N07 | M_RESETN | P07 | M_PDOWN | R07 | M_DATAN0 |
| N08 | VSS | P08 | M_DATAP0 | R08 | M_CLKN |
| N09 | ISP_SDA | P09 | M_CLKP | R09 | M_DATAN1 |
| N10 | Z_REXT | P10 | M_DATAP1 | R10 | Z_DATAN1 |
| N11 | Z_PDOWN | P11 | Z_DATAP1 | R11 | Z_CLKN |
| N12 | Z_SCL | P12 | Z_CLKP | R12 | Z_DATAN0 |
| N13 | Z_SDA | P13 | Z_DATAP0 | R13 | Z_RCLK |
| N14 | SPI_MOSI | P14 | Z_RESETN | R14 | Z_VSYNC |
| N15 | SPI_MISO | P15 | CW_CSR_RSTN | R15 | Z_AGND |

3.3.4 Vision Processor D4 Power Requirements

The Vision Processor D4 requires the following power supplies for operation.

Table 3-6. Vision Processor D4 Power Requirements

| Voltage Ball Name | Min. (V) | Nominal (V) | Max. (V) | Peak Current (I _{cc}) |
|---------------------------|----------|-------------|----------|---------------------------------|
| VDD | 0.85 | 0.9 | 0.95 | 0.4A |
| VDD_PG | 0.85 | 0.9 | 0.95 | 1.6A |
| USB_DVDD | 0.81 | 0.9 | 0.99 | 0.2A |
| VPTX0 | 0.81 | 0.9 | 0.99 | 0.2A |
| VP | 0.81 | 0.9 | 0.99 | 0.2A |
| *AVDD | 1.71 | 1.8 | 1.89 | 0.2A |
| VDDPLL | 0.85 | 0.9 | 0.95 | 0.2A |
| VDDTS | 1.71 | 1.8 | 1.89 | 0.2A |
| VDDPST18 (Left and Right) | 1.71 | 1.8 | 1.89 | 0.2A |
| USB_VDD330 | 3.13 | 3.3 | 3.46 | 0.2A |

3.3.5 Vision Processor D4 Power Sequencing

The timing requirement for power sequencing is listed below and shown in the following figure.

- Hold Vision Processor D4 in reset
- Ramp up power in the 3.3V
- Ramp up power in the 0.9V
- Ramp up power in the 1.8V
- Release Vision Processor D4 Reset

Table 3-7. Vision Processor D4 Power Sequencing Timing Parameters

| Parameter | Value | Units | Label |
|---|-------|-------|-------|
| 0.9V stable to 3.3V stable | >=50 | us | T1 |
| PMU_PWR_EN to 0.9V Stable | >=50 | us | T2 |
| 1.8V stable to 0.9V Stable | >=50 | us | T3 |
| PRSTN (D4 RESET) assertion to 1.8V stable | 15 | us | T4 |

Figure 3-3. Vision Processor D4 Power Sequencing

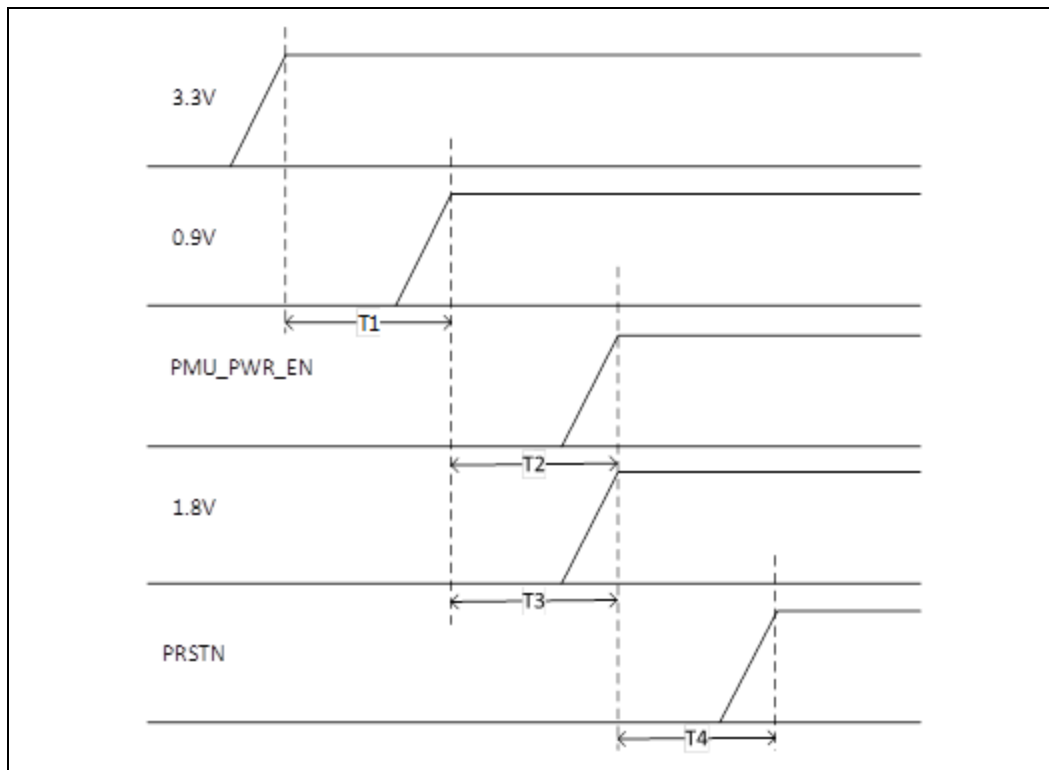

Note: Vision Processor D4 has no specific power down sequence requirement.

3.3.6 Vision Processor D4 Spec Code

The spec code is an identification mark printed on Vision Processor D4.

Table 3-8. Vision Processor D4 SPEC Code

| Vision Processor D4 | SPEC CODE |
|---------------------------------------|-----------|
| Production (Shipped in Tape and Reel) | SLLY5 |
| Production (Shipped in Tray) | SLM6B |

3.3.7 Vision Processor D4 Storage and Operating Conditions

Table 3-9. Vision Processor D4 Storage and Operating Conditions

| Condition | Description | Min | Max | Unit |
|------------------------------------|--|-----|-----|------|
| Storage (Still Air), Not Operating | Temperature (Sustained, Controlled) ⁽¹⁾ | 0 | 40 | °C |

| | | | | |
|---|---|-----------------------------|-----|----|
| | Temperature (Short Exposure) ⁽²⁾ | -40 | 70 | °C |
| | Humidity | Temperature/ RH: 40°C / 90% | | |
| Component Case Temperature ⁽³⁾ | Temperature | 0 | 110 | °C |

NOTE:

- (1) Controlled conditions should be used for long term storage of product.
- (2) Short exposure represents temporary max limits acceptable for transportation conditions.
- (3) Component case temperature limits must be met for all operating temperatures.

3.3.8 Vision Processor D4 Thermals

The thermal design should be such that Vision Processor D4 does not exceed component case temperature limit. Care must also be taken to make sure that the Vision Processor D4 heat is not transferred to other components of the imaging system or stereo depth module. It will be best to thermally isolate Vision Processor D4 from the stereo depth module.

3.4 Clock

Vision Processor D4 requires a single 24 MHz clock oscillator. All clocks required by stereo depth module are generated by Vision Processor D4.

3.5 Serial (SPI) Flash Memory

Vision Processor D4 requires 16Mbit Serial Flash Memory for its firmware storage. The recommended part number is IS25WP016 (www.issi.com) or equivalent

3.6 Stereo Depth Module

The stereo depth module components are described in Table 3-10. The stereo depth printed circuit board and components are encapsulated in a common metal stiffener.

Table 3-10. Stereo Depth Module

| Component | Description |
|-------------------------|---|
| Left and Right Imagers | 2 HD image sensors |
| Infrared (IR) Projector | Class 1 laser compliant (optional) |
| Color Sensor | 1080p RGB image sensor (optional) |
| Depth Module Connector | 50 pin connector plug |
| Privacy LED | Indicator when stereo module is streaming data (optional) |
| Stiffener | Reinforcement housing to keep imagers aligned |
| Label | Manufacture and product identifier information |

| | |
|------------------|--|
| Other Components | Laser Driver, EEPROM, Voltage Regulators, etc. |
|------------------|--|

Figure 3-4. Stereo Depth Module (Intel® RealSense™ Depth Module D410)

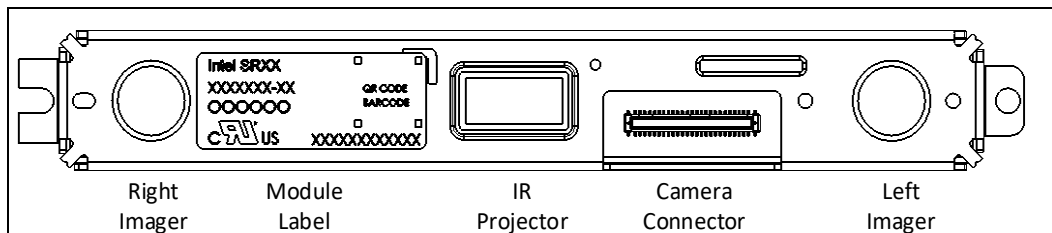

Figure 3-5. Stereo Depth Module (Intel® RealSense™ Depth Module D430)

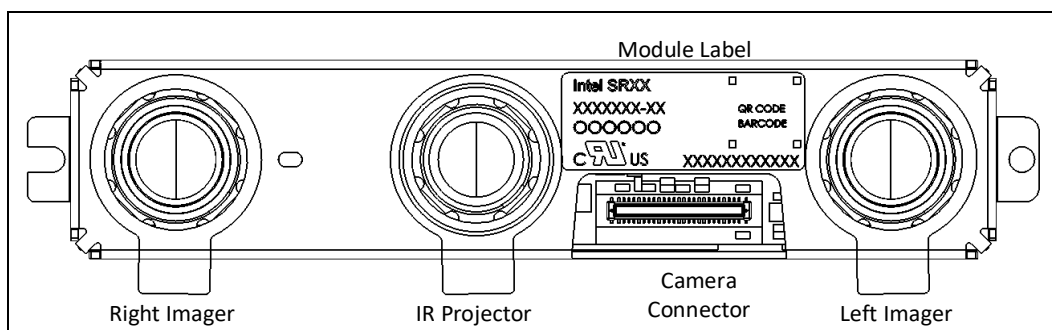

Table 3-11. Stereo Depth Module SKU Properties

| Stereo Module | Intel® RealSense™ Depth Module D400 | Intel® RealSense™ Depth Module D410 | Intel® RealSense™ Depth Module D415 | Intel® RealSense™ Depth Module D420 | Intel® RealSense™ Depth Module D430 |
|-------------------------|-------------------------------------|-------------------------------------|-------------------------------------|-------------------------------------|-------------------------------------|
| Baseline | 55mm | 55mm | 55mm | 50mm | 50mm |
| Left/Right Imagers Type | Standard | Standard | Standard | Wide | Wide |
| Depth FOV HD (degrees) | H:65±2 / V:40±1 / D:72±2 | H:65±2 / V:40±1 / D:72±2 | H:65±2 / V:40±1 / D:72±2 | H:87±3 / V:58±1 / D:95±3 | H:87±3 / V:58±1 / D:95±3 |
| Depth FOV VGA (degrees) | H:50±2 / V:40±1 / D:61±2 | H:50±2 / V:40±1 / D:61±2 | H:50±2 / V:40±1 / D:61±2 | H:75±3 / V:62±1 / D:89±3 | H:75±3 / V:62±1 / D:89±3 |
| IR Projector | - | Standard | Standard | - | Wide |
| IR Projector FOV | - | H:67 / V:41 / D:75 | H:67 / V:41 / D:75 | - | H:90 / V:63 / D:99 |
| Color Sensor | - | - | OV2740 | - | - |
| Color Camera FOV | - | - | H:69±1 / V:42±1 / D:77±1 | - | - |

| | | | | | |
|------------------------|-------------------------------|-------------------------------|-------------------------------|---------------------------------|---------------------------------|
| Module Dimensions (mm) | X=74.7mm Y=10mm Z=4.7mm | X=74.7mm Y=10mm Z=4.7mm | X=83.7mm Y=10mm Z=4.7mm | X=70.7mm Y=14mm Z=10.53mm | X=70.7mm Y=14mm Z=10.53mm |
|------------------------|-------------------------------|-------------------------------|-------------------------------|---------------------------------|---------------------------------|

NOTE:

- H – Horizontal FOV, V – Vertical FOV, D – Diagonal FOV, X – Length, Y – Breadth, Z – Thickness
- Depth FOV specified at 2 meters
- Due to mechanical tolerances of +/-5%, Max and Min FOV values can vary from lens to lens and module to module by ~ +/- 3 degrees.

3.6.1 Left and Right Imagers

The stereo depth module has two camera sensors referred here as imagers, they are identical parts and are configured with identical settings. The imagers are labeled “left” and “right” from the perspective of the camera module looking outward. The stereo imager pairs are referred as Standard or Wide based on imager field of view.

Table 3-12. Standard Left and Right Imager Properties

| Parameter | Camera Sensor Properties |
|--------------------------|---|
| Image Sensor | OmniVision OV2740 |
| Active Pixels | 1920 × 1080 |
| Sensor Aspect Ratio | 16:9 |
| Format | 10-bit RAW |
| F Number | f/2.0 |
| Focal Length | 1.88mm |
| Filter Type | IR Cut – D400, None – D410, D415, Camera D415 |
| Focus | Fixed |
| Shutter Type | Rolling Shutter |
| Signal Interface | MIPI CSI-2, 2X Lanes |
| Horizontal Field of View | 69.4° |
| Vertical Field of View | 42.5° |
| Diagonal Field of View | 77° |
| Distortion | <=1.5% |

Table 3-13. Wide Left and Right Imager Properties

| Parameter | Camera Sensor Properties |
|---------------------|--------------------------|
| Image Sensor | OmniVision OV9282 |
| Active Pixels | 1280 X 800 |
| Sensor Aspect Ratio | 8:5 |

| Parameter | Camera Sensor Properties |
|--------------------------|--|
| Format | 10-bit RAW |
| F Number | f/2.0 |
| Focal Length | 1.93mm |
| Filter Type | IR Cut – D420, None – D430, D435/D435i |
| Focus | Fixed |
| Shutter Type | Global Shutter |
| Signal Interface | MIPI CSI-2, 2X Lanes |
| Horizontal Field of View | 91.2° |
| Vertical Field of View | 65.5° |
| Diagonal Field of View | 100.6° |
| Distortion | <=1.5% |

3.6.2 Infrared Projector

The infrared projector improves the ability of the stereo camera system to determine depth by projecting a static infrared pattern on the scene to increase texture on low texture scenes. The infrared projector meets class 1 laser safety under normal operation. The power delivery and laser safety circuits are on the stereo depth module. The infrared projector is referred as Standard or Wide based on field of projection.

Table 3-14. Standard Infrared Projector Parameters

| Parameter | Properties |
|--------------------------------|---|
| Projector | Infrared |
| Pattern Type | Static |
| Illuminating Component | Vertical-cavity surface-emitting laser (VCSEL) + Optics |
| Laser Controller | PWM |
| Optical Power | 360mW average, 440mW peak |
| Laser Wavelength | 850nm ± 10 nm nominal @ 20°C |
| Laser Compliance | Class 1, IEC 60825-1:2007 Edition 2, IEC 60825-1:2014 Edition 3 |
| Horizontal Field of Projection | 64°±3° |
| Vertical Field of Projection | 41°±3° |
| Diagonal Field of Projection | 72°±3° |

Table 3-15. Wide Infrared Projector Parameters

| Parameter | Properties |
|-----------|------------|
| Projector | Infrared |

| Parameter | Properties |
|--------------------------------|---|
| Pattern Type | Static |
| Illuminating Component | Vertical-cavity surface-emitting laser (VCSEL) + optics |
| Laser Controller | PWM |
| Optical Power | 360mW average, 4.25W peak |
| Laser Wavelength | 850nm ± 10 nm nominal @ 20°C |
| Laser Compliance | Class 1, IEC 60825-1:2007 Edition 2, IEC 60825-1:2014 Edition 3 |
| Horizontal Field of Projection | 86°±3° |
| Vertical Field of Projection | 57°±3° |
| Diagonal Field of Projection | 94°±3° |

3.6.3 Color Sensor

The color sensor on the stereo depth module in addition to color image provides texture information. Usages for the texture information include overlay on a depth image to create a color point cloud and overlay on a 3d model for reconstruction.

Table 3-16. Color Sensor Properties

| Parameter | Camera Sensor Properties |
|------------------------------|--------------------------|
| Image Sensor | OmniVision OV2740 |
| Color Image Signal Processor | Discrete |
| Active Pixels | 1920 X 1080 |
| Sensor Aspect Ratio | 16:9 |
| Format | 10-bit RAW RGB |
| F Number | f/2.0 |
| Focal Length | 1.88mm |
| Filter Type | IR Cut Filter |
| Focus | Fixed |
| Shutter Type | Rolling Shutter |
| Signal Interface | MIPI CSI-2, 1 Lane |
| Horizontal Field of View | 69.4° |
| Vertical Field of View | 42.5° |
| Diagonal Field of View | 77° |
| Distortion | <=1.5% |

3.6.4 Depth Module Connector

The depth module connector provides signal and power interface to the stereo depth module. The connector on stereo depth module is a 50-pin connector plug.

Table 3-17. Depth Module 50-pin Connector Plug Details

| Parameter | Description | Diagram |
|----------------------|------------------------------|---------|
| Number of Contacts | 50 | |
| Product Name | NOVASTACK 35-P Plug Assembly | |
| Part Number | 20708-050E | |
| Manufacturer Website | www.i-pex.com | |

3.6.5 Stereo Depth Module Label

Table 3-18. Stereo Depth Module Product Labeling

| <p><u>For illustration purpose only, subject to change</u></p> | <table border="1"> <thead> <tr> <th></th> <th>Dimension</th> <th>Value</th> <th>Unit</th> </tr> </thead> <tbody> <tr> <td>A</td> <td>Label Width</td> <td>17</td> <td>mm</td> </tr> <tr> <td>B</td> <td>Label Height</td> <td>6.9</td> <td>mm</td> </tr> <tr> <td>C</td> <td>Scan Code Width</td> <td>5</td> <td>mm</td> </tr> <tr> <td>D</td> <td>Scan Code Height</td> <td>5</td> <td>mm</td> </tr> </tbody> </table> | | | | Dimension | Value | Unit | A | Label Width | 17 | mm | B | Label Height | 6.9 | mm | C | Scan Code Width | 5 | mm | D | Scan Code Height | 5 | mm |
|---|---|-----------------|-------|------|-----------|-------|------|---|-------------|----|----|---|--------------|-----|----|---|-----------------|---|----|---|------------------|---|----|
| | | Dimension | Value | Unit | | | | | | | | | | | | | | | | | | | |
| | A | Label Width | 17 | mm | | | | | | | | | | | | | | | | | | | |
| | B | Label Height | 6.9 | mm | | | | | | | | | | | | | | | | | | | |
| | C | Scan Code Width | 5 | mm | | | | | | | | | | | | | | | | | | | |
| D | Scan Code Height | 5 | mm | | | | | | | | | | | | | | | | | | | | |
| <p align="center">Scan Code Format XXXXXXXXXXXXX000000XXXXXXXX-XXX</p> | | | | | | | | | | | | | | | | | | | | | | | |
| | | | | | | | | | | | | | | | | | | | | | | | |
| | | | | | | | | | | | | | | | | | | | | | | | |
| | | | | | | | | | | | | | | | | | | | | | | | |

Table 3-19. Stereo Depth Module Label Fields

| Group | Field | Description | Type |
|-------------------------|-----------------------|--------------------------------|---------|
| Company | Intel | Manufacturer | Static |
| Model Number | RealSense™ Camera 4XX | Camera Model Number | Static |
| Product Assembly Number | XXXXXX | Product Identifier Code | Static |
| | -XXX | Manufacture Configuration Code | Dynamic |
| | 000000 | Product Material Code | Static |
| Serial Number | XXXXXXXXXXXXX | Manufacture Unit Code | Dynamic |

Table 3-20. Intel® RealSense™ Depth Module D400 Series Product Identifier Code and Product Material Code

| Production | Product Identifier Code- Manufacture Configuration Code | Product Material Code |
|-------------------|--|-----------------------|
| Depth Module D400 | J32082-100 | 951934 |
| Depth Module D410 | J32106-100 | 951913 |
| Depth Module D415 | J32114-100 | 952000 |
| Depth Module D420 | J51355-100 | 956826 |
| Depth Module D430 | J42086-100 | 954010 |

3.6.6 Stiffener

The stiffener maintains the precise alignment of the camera sensors and assists in subassembly rigidity. The stiffener consists of a bottom and a top plate. The stiffener is of stainless steel grade AISI 304.

3.6.7 Temperature Sensor

The stereo depth module is equipped with a thermal sensor that is used for laser safety control (IR Projector). The RealSense library provides access to the thermal sensor but it is not intended to be used by applications outside of development environments.

3.6.8 Other Stereo Depth Module Components

Table 3-21. Other Stereo Depth Module Components

| Component | Description |
|--------------------------------------|--|
| Laser (IR Projector) Driver | The depth module implements a laser driver which controls the infrared laser within the infrared projector system. |
| Laser (IR projector) Thermal Control | The depth module implements a laser safety control circuit that adjusts laser drive output. When laser power and depth streaming is enabled and if stereo depth module temperature is >60°, laser power is halved. If temperature is not lowered below temperature limit within a certain interval, the laser is shut off. |
| EEPROM | The depth module implements flash memory for storing the calibration data. |
| Fork/Screw Mount | Secure placement and mounting to system/chassis/heat sink |
| Voltage Regulators | The stereo depth module implements DC to DC voltage converters |

3.6.9 Mechanical Dimensions

Table 3-22. Intel® RealSense™ Depth Module D400 Mechanical Dimensions

| Dimension | Min | Nominal | Max | Unit |
|--------------------|------|---------|------|------|
| Width | 74.5 | 74.7 | 74.9 | mm |
| Height | 9.8 | 10 | 10.2 | mm |
| Depth | 4.5 | 4.7 | 4.9 | mm |
| Flatness Tolerance | - | 0.2 | - | mm |
| Weight | 6.5 | 7.2 | 8 | gr |

Table 3-23. Intel® RealSense™ Depth Module D410 Mechanical Dimensions

| Dimension | Min | Nominal | Max | Unit |
|--------------------|------|---------|------|------|
| Width | 74.5 | 74.7 | 74.9 | mm |
| Height | 9.8 | 10 | 10.2 | mm |
| Depth | 4.5 | 4.7 | 4.9 | mm |
| Flatness Tolerance | - | 0.2 | - | mm |
| Weight | 7.3 | 8.1 | 8.9 | gr |

Table 3-24. Intel® RealSense™ Depth Module D415 Mechanical Dimensions

| Dimension | Min | Nominal | Max | Unit |
|--------------------|------|---------|------|------|
| Width | 89.5 | 89.7 | 89.9 | mm |
| Height | 9.8 | 10 | 10.2 | mm |
| Depth | 4.5 | 4.7 | 4.9 | mm |
| Flatness Tolerance | | TBD | | mm |
| Weight | | TBD | | gr |

Table 3-25. Intel® RealSense™ Depth Module D420 Mechanical Dimensions

| Dimension | Min | Nominal | Max | Unit |
|--------------------|-------|---------|-------|------|
| Width | 70.5 | 70.7 | 70.9 | mm |
| Height | 13.8 | 14 | 14.2 | mm |
| Depth | 10.33 | 10.53 | 10.73 | mm |
| Flatness Tolerance | - | 0.2 | - | mm |
| Weight | | TBD | | gr |

Table 3-26. Intel® RealSense™ Depth Module D430 Mechanical Dimensions

| Dimension | Min | Nominal | Max | Unit |
|--------------------|-------|---------|-------|------|
| Width | 70.5 | 70.7 | 70.9 | mm |
| Height | 13.8 | 14 | 14.2 | mm |
| Depth | 10.33 | 10.53 | 10.73 | mm |
| Flatness Tolerance | - | 0.2 | - | mm |
| Weight | 13 | 14.5 | 16 | gr |

3.6.10 Stereo Depth Module Power Sequence

Figure 3-6. Stereo Depth Module Power Sequence

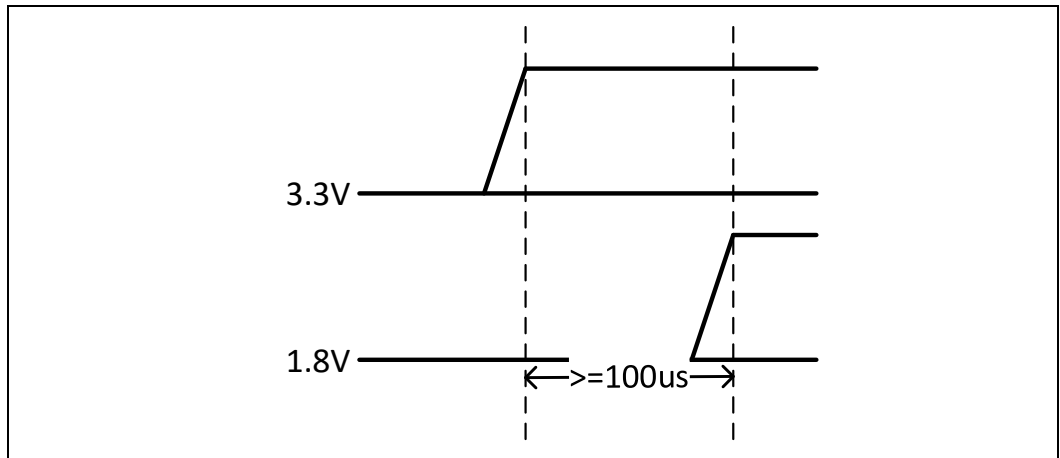

3.6.11 Stereo Depth Module Storage and Operating Conditions

Table 3-27. Stereo Depth Module Storage and Operating Conditions

| Condition | Description | Min | Max | Unit |
|---------------------------------------|--|-----------------------------|-----|------|
| Storage (Ambient), Not Operating | Temperature (Sustained, Controlled) ⁽¹⁾ | 0 | 40 | °C |
| | Temperature (Short Exposure) ⁽²⁾ | -40 | 70 | °C |
| | Humidity | Temperature/ RH: 40°C / 90% | | |
| Case Temperature ⁽³⁾⁽⁴⁾⁽⁵⁾ | Temperature | 0 | 50 | °C |

NOTE:

- (1) Controlled conditions should be used for long term storage of product.
- (2) Short exposure represents temporary max limits acceptable for transportation conditions.
- (3) Case temperature limits must be met for all operating temperatures.
- (4) Case temperature is specified for the overall depth module
- (5) Case temperature 0° minimum and lower temperatures is non-condensing

3.7 Intel® RealSense™ Vision Processor D4 Board

The Vision Processor D4 Board enables an easy and quick option for system integrators to integrate Vision Processor D4 into a system.

Table 3-28. Vision Processor D4 Board

| Type | Description |
|-----------------------|--|
| USB Peripheral Type-C | Connects to Host USB 3.1 Gen 1 port through USB Type-C connector and cable |

Table 3-29. Vision Processor D4 Board Components

| Components | Description |
|---|---|
| Vision Processor D4 | Stereo Depth Processing ASIC |
| 16Mb Serial Flash | Vision Processor D4 firmware storage |
| 24MHz Crystal | Clock source for Vision Processor D4 |
| Realtek* ISP with external serial flash | Color image signal processor |
| Depth Module Receptacle | 50 pin receptacle for connection to Stereo Depth Module |
| USB Type-C | USB peripheral connector for connection to Host USB 2.0/USB 3.1 Gen 1 port |
| External Sensor Sync Connector | Interface to external sensor interrupts/sync signals |
| Voltage Regulators | DC to DC converters powering Vision Processor D4 Board and stereo depth module. |
| Mounting holes | Vision Processor D4 Board secure mounting |

Figure 3-7. Vision Processor D4 Board (USB Peripheral Type-C)

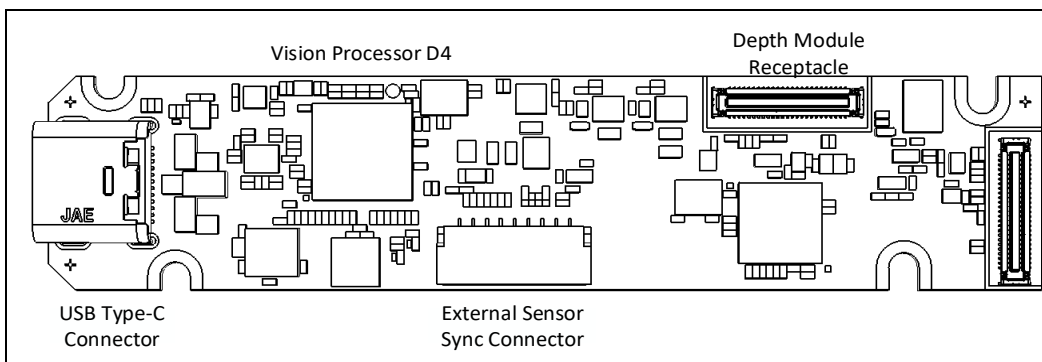

3.7.1 Mechanical Dimensions

Table 3-30. Vision Processor D4 USB Type-C Board Mechanical Dimensions

| Dimension | Min | Nominal | Max | Unit |
|-----------|------|---------|------|------|
| Width | 72.2 | 72.4 | 72.6 | mm |
| Height | 15.8 | 16 | 16.2 | mm |
| Depth | 3.74 | 3.94 | 4.14 | mm |
| Weight | 3.56 | 3.96 | 4.36 | gr |

3.7.2 Depth Module Receptacle

The Vision Processor D4 Board interface to stereo depth module is through 50 pin receptacle on the board.

Table 3-31. Depth Module Receptacle Details

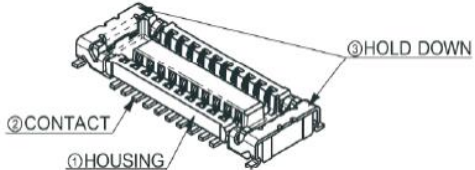
| Parameter | Description | Diagram |
|----------------------|-------------------------------------|---|
| Number of Contacts | 50 |  |
| Product Name | NOVASTACK* 35-P Receptacle Assembly | |
| Part Number | 20709-050E | |
| Manufacturer Website | www.i-pex.com | |

3.7.3 Flex and Rigid Interposer Interconnect

The high speed interposer at one end has the 50 pin depth module receptacle to connect into 50 pin depth module plug on stereo depth module and at the other end has the 50 pin depth module plug to connect into 50 pin depth module receptacle on Vision Processor D4 Board. The high speed flex Interposer is custom developed and procured by system integrator.

Figure 3-8. Flex Interposer (Illustration)

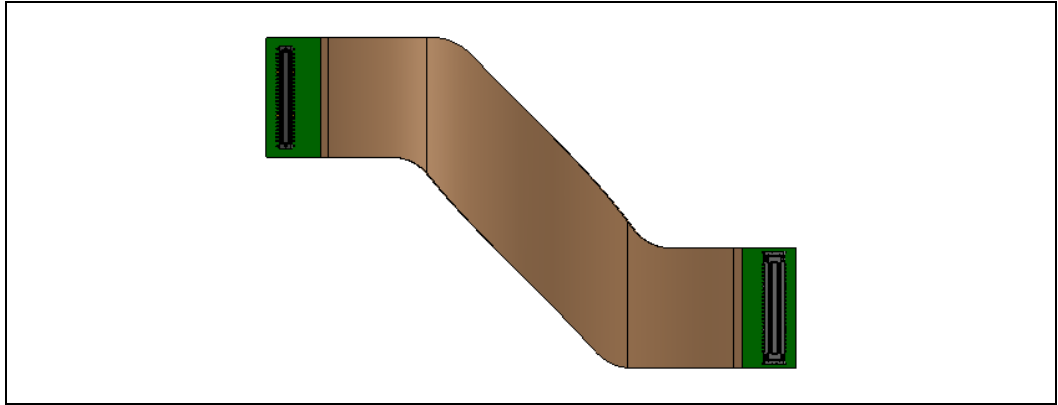

Figure 3-9. Rigid Interposer (Illustration)

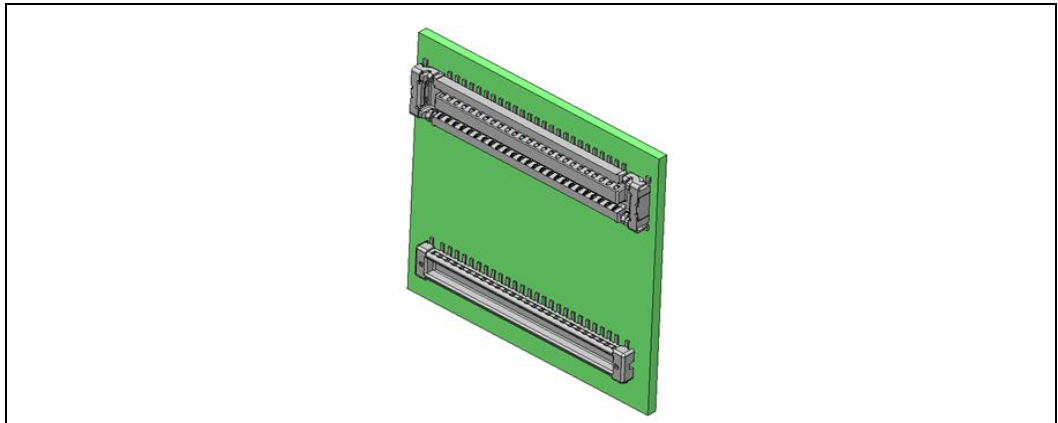

Figure 3-10. Depth Module Receptacle and Plug Connector Pin Position

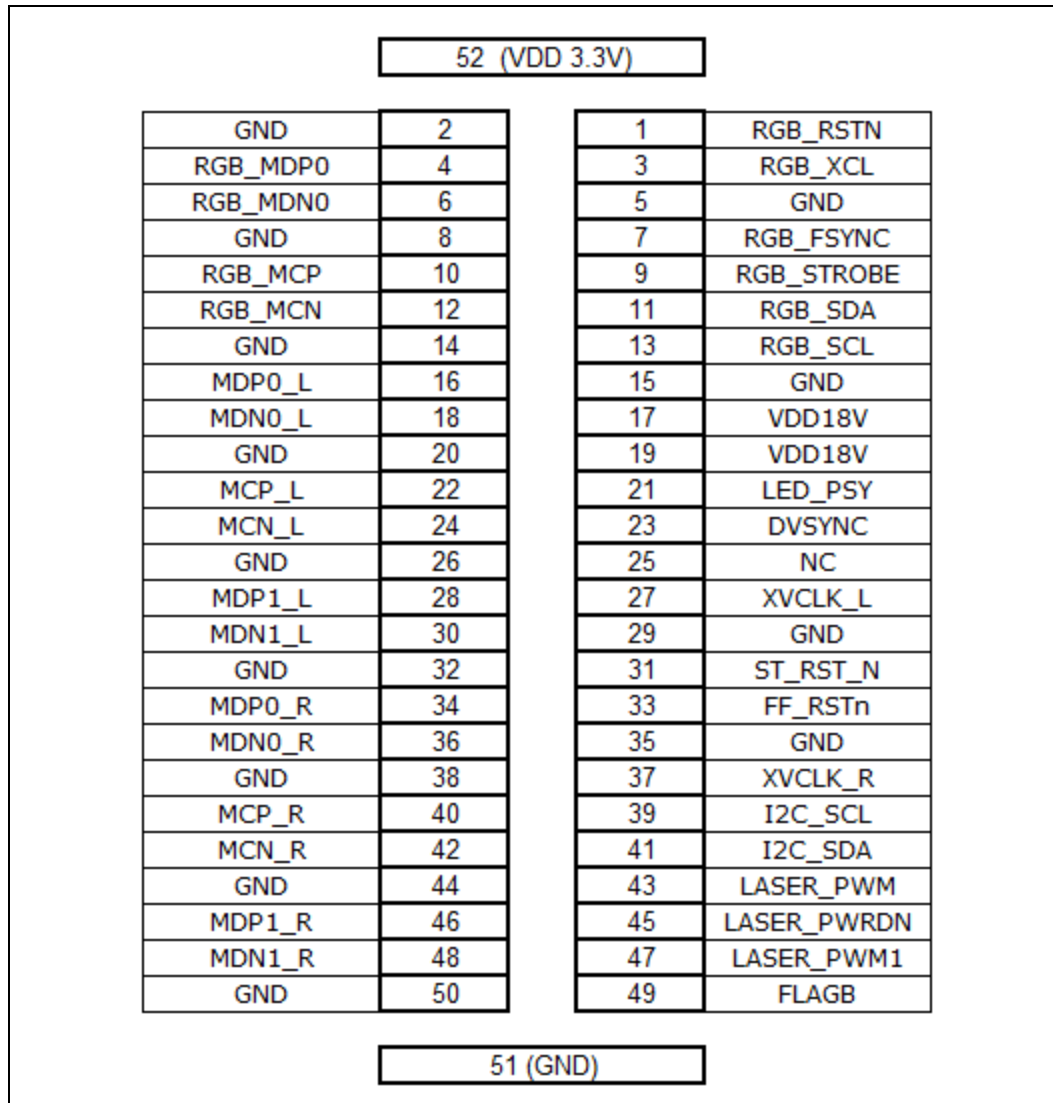

Table 3-32. Interposer Interconnect Signal Description

| Position | ASIC Board/ Motherboard | Depth Module | Interconnect Description |
|----------|----------------------------|--------------|--|
| 1 | RGB_RSTN_N | RGB_RSTN_N | RGB Sensor Reset |
| 2 | GND | GND | Ground |
| 3 | RGB_XCL | RGB_XCL | RGB Sensor Clock |
| 4 | RGB_MDP0 | RGB_MDP0 | RGB Sensor MIPI Data Lane 0 differential pair positive |
| 5 | GND | GND | Ground |
| 6 | RGB_MDNO | RGB_MDNO | RGB Sensor MIPI Data Lane 0 differential pair negative |

| Position | ASIC Board/ Motherboard | Depth Module | Interconnect Description |
|----------|----------------------------|--------------|--|
| 7 | RGB_FSYNC | RGB_FSYNC | RGB Sensor Sync |
| 8 | GND | GND | Ground |
| 9 | RGB_STROBE | RGB_STROBE | RGB Sensor Strobe |
| 10 | RGB_MCP | RGB_MCP | RGB Sensor MIPI Clock differential pair positive |
| 11 | RGB_SDA | RGB_SDA | RGB Sensor I2C Bus Data |
| 12 | RGB_MCN | RGB_MCN | RGB Sensor MIPI Clock differential pair negative |
| 13 | RGB_SCL | RGB_SCL | RGB Sensor I2C Bus Clock |
| 14 | GND | GND | Ground |
| 15 | GND | GND | Ground |
| 16 | MDP0_L | MDP0_L | Left Imager MIPI Data Lane 0 differential pair positive |
| 17 | VDD18V | VDD18V | 1.8V Power |
| 18 | MDN0_L | MDN0_L | Left Imager MIPI Data Lane 0 differential pair negative |
| 19 | VDD18V | VDD18V | 1.8V Power |
| 20 | GND | GND | Ground |
| 21 | LED_PSY | LED_PSY | Privacy LED control signal |
| 22 | MCP_L | MCP_L | Left Imager MIPI Clock differential pair positive |
| 23 | DVSYNC | DVSYNC | VSYNC |
| 24 | MCN_L | MCN_L | Left Imager MIPI Clock differential pair negative |
| 25 | NC | NC | No Connect |
| 26 | GND | GND | Ground |
| 27 | XVCLK_L | XVCLK_L | Clock to Left Imager |
| 28 | MDP1_L | MDP1_L | Left Imager MIPI Data Lane 1 differential pair positive |
| 29 | GND | GND | Ground |
| 30 | MDN1_L | MDN1_L | Left Imager MIPI Data Lane 1 differential pair negative |
| 31 | ST_RST_N | ST_RST_N | Reset signal to Left and Right Imager |
| 32 | GND | GND | Ground |
| 33 | FF_RSTn | FF_RSTn | Laser Error |
| 34 | MDP0_R | MDP0_R | Right Imager MIPI Data Lane 0 differential pair positive |
| 35 | GND | GND | Ground |
| 36 | MDN0_R | MDN0_R | Right Imager MIPI Data Lane 0 differential pair negative |
| 37 | XVCLK_R | XVCLK_R | Clock to Right Imager |
| 38 | GND | GND | Ground |

| Position | ASIC Board/ Motherboard | Depth Module | Interconnect Description |
|----------|----------------------------|--------------|--|
| 39 | I2C_SCL | I2C_SCL | I2C Bus Clock |
| 40 | MCP_R | MCP_R | Right Imager MIPI Clock differential pair positive |
| 41 | I2C_SDA | I2C_SDA | I2C Bus Data |
| 42 | MCN_R | MCN_R | Right Imager MIPI Clock differential pair negative |
| 43 | LASER_PWM | LASER_PWM | IR Projector Control Signal |
| 44 | GND | GND | Ground |
| 45 | LASER_PWRDN | LASER_PWRDN | IR Projector Power Down |
| 46 | MDP1_R | MDP1_R | Right Imager MIPI Data Lane 1 differential pair positive |
| 47 | LASER_PWM1 | LASER_PWM1 | IR Projector Control Signal |
| 48 | MDN1_R | MDN1_R | Right Imager MIPI Data Lane 1 differential pair negative |
| 49 | FLAGB | FLAGB | IR Projector Fault Detect |
| 50 | GND | GND | Ground |
| 51 | GND | GND | Ground |
| 52 | VDD33V | VDD33V | 3.3V power |

Figure 3-11. Depth Module Connector Orientation and Pin Position

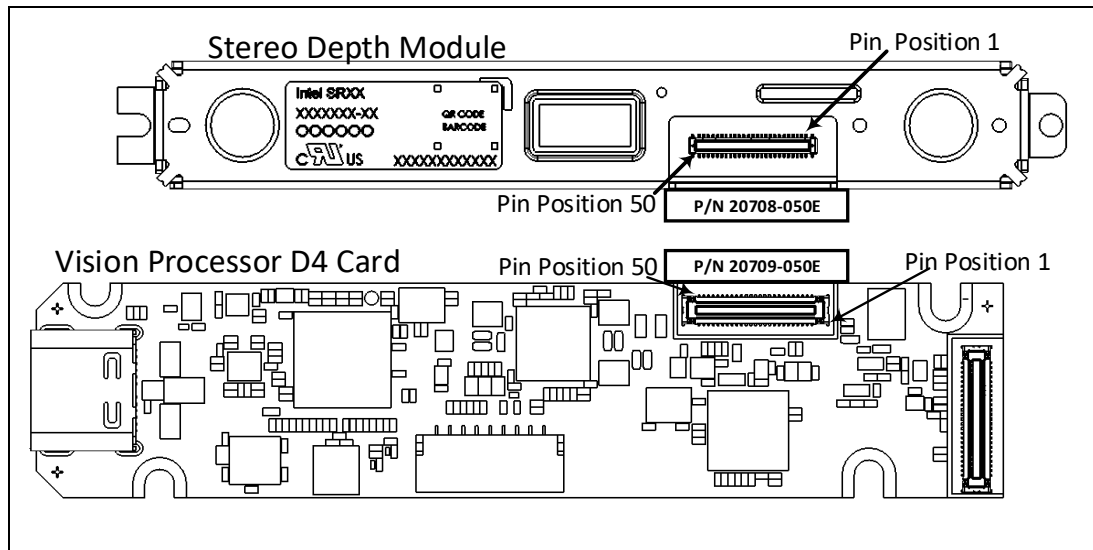

Table 3-33. Custom Flex Interposer Ordering Logistics

| Vendor | Sales Contact |
|---------------------------------|--|
| COCOM CONSUMER ELECTRONICS LTD. | Janine Langdale email: Janine.Langdale@cc-e.co.uk |

| | |
|--|--|
| | (O) +44 (0) 1444 461620 (M) +44 (0) 7905 692131 |
|--|--|

3.7.4 External Sensor Sync Connector

The external sensor connector provides the interface for external sensors to synchronize to depth output.

Table 3-34. External Sensor Connector Details

| Parameter | Description | Diagram |
|----------------------|--|---------|
| Number of Contacts | 9 | |
| Product Name | 9 Positions Header, Shrouded Connector | |
| Part Number | SM09B-SRSS-TB(LF)(SN) | |
| Manufacturer Website | www.jst-mfg.com | |

Table 3-35. External Sensor Sync Connector Pin List

| Pin | Signal | Function | Description |
|-----|------------|------------|------------------------------------|
| 1 | GPIO3 | GVSYNCO | Not Defined |
| 2 | GPIO4 | GVSYNCO1 | IR Projector Power Down signal |
| 3 | GPIO5 | GVSYNCO2 | External IR Projector Fault Detect |
| 4 | GPIO6 | GVSYNCO3 | External IR Projector |
| 5 | Z_VSYNC | VSYNC | Depth VSYNC |
| 6 | LASER_PWM0 | LASER PWM0 | Laser control signal |
| 7 | LASER_PWM1 | LASER PWM1 | Laser control signal |
| 8 | VDD33V | Power | 3.3V |
| 9 | GND | Ground | Ground |

3.7.5 USB Peripheral Connector – Type-C

USB Type-C connector consists of 24 signal pins designed in a symmetrical way. The connector z height is as low as 3mm and enables enhanced user experience by allowing the USB Type-C plug to be plugged into a receptacle either right side up or upside down. Interoperability between USB Type-C and legacy USB is possible through standard legacy cable assemblies defined in USB Type-C Cable and Connector specification.

Figure 3-12. USB Type-C Receptacle Pin Map

| | | | | | | | | | | | |
|-----|------|------|------|------|----|----|------|------|------|------|-----|
| A1 | A2 | A3 | A4 | A5 | A6 | A7 | A8 | A9 | A10 | A11 | A12 |
| GND | TX1+ | TX1- | VBUS | CC1 | D+ | D- | SBU1 | VBUS | RX2- | RX2+ | GND |
| GND | RX1+ | RX1- | VBUS | SBU2 | D- | D+ | CC2 | VBUS | TX2- | TX2+ | GND |
| B12 | B11 | B10 | B9 | B8 | B7 | B6 | B5 | B4 | B3 | B2 | B1 |

Table 3-36. USB Peripheral Connector Pin List

| Pin | Signal | Function | Description |
|-----|--------|----------------------|---|
| A1 | GND | Power Delivery | Ground |
| A2 | TX1+ | USB 3.1 Gen 1 Data | First SuperSpeed TX Differential Pair Positive |
| A3 | TX1- | USB 3.1 Gen 1 Data | First SuperSpeed TX Differential Pair Negative |
| A4 | VBUS | Power Delivery | 5V |
| A5 | CC1 | Control | Configuration Channel 1 |
| A6 | D+ | USB2.0 Data | USB 2.0 differential pair positive |
| A7 | D- | USB2.0 Data | USB 2.0 differential pair negative |
| A8 | SBU1 | Sideband | Sideband Use Signal 1 |
| A9 | VBUS | Power Delivery | 5V |
| A10 | RX2- | USB 3.1 Gen 1 Data | Second SuperSpeed RX Differential Pair Negative |
| A11 | RX2+ | USB 3.1 Gen 1 Data | Second SuperSpeed RX Differential Pair Positive |
| A12 | GND | Power Delivery | Ground |
| B1 | GND | Power Delivery | Ground |
| B2 | TX2+ | USB 3.1 Gen 1 Data | Second SuperSpeed TX Differential Pair Positive |
| B3 | TX2- | USB 3.1 Gen 1 Data | Second SuperSpeed TX Differential Pair Negative |
| B4 | VBUS | Power Delivery | 5V |
| B5 | CC2 | Control | Configuration Channel 2 |
| B6 | D+ | USB 2.0 Data | USB 2.0 differential pair positive |
| B7 | D- | USB 2.0 Data | USB 2.0 differential pair negative |
| B8 | SBU2 | Sideband | Sideband Use Signal 2 |
| B9 | VBUS | Power Delivery | 5V |
| B10 | RX1- | USB 3.1 Gen 1.0 Data | First SuperSpeed RX Differential Pair Negative |
| B11 | RX1+ | USB 3.1 Gen 1.0 Data | First SuperSpeed RX Differential Pair Positive |
| B12 | GND | Power Delivery | Ground |

Table 3-37. Custom USB Type C cable Assemblies Ordering Logistics

| Vendor | Website |
|-------------------------|---|
| Newnex Technology Corp. | http://www.newnex.com/realsense-3d-camera-connectivity.php |

3.7.6 Color Image Signal Processor (ISP)

The color sensor data is sent to discrete Image Signal Processor (ISP) on the Vision processor D4 Board for image adjustments, image scaling and processing functions to help compensate for inherent inaccuracy in lens and sensor in providing a better image quality. The processed color image is sent to the Vision Processor D4.

Table 3-38. ISP Properties

| Parameter | ISP Properties |
|--|---------------------------------|
| ISP Part Number on Vision Processor D4 Board | RTS5845 |
| 1M-bit Serial Flash for ISP | Winbond* W25X10CL or equivalent |
| Interface To Vision Processor D4 | MIPI CSI-2, 2X Lanes |
| Interface To RGB Sensor | MIPI CSI-2, 1X Lane |

3.7.7 Vision Processor D4 Board Power Requirements

The Vision Processor D4 Board is powered through VBUS power of the USB connector. The Vision Processor D4 Board in turn power sources the stereo depth module.

Table 3-39. Vision Processor D4 Board Power Requirements

| Parameter | | Min | Nom | Max | Unit |
|-----------|--------------------------|------|-----|-------|------|
| VCC | Supply Voltage | 4.75 | 5V | 5.25V | V |
| ICC | Supply Current | | | 700 | mA |
| | Supply Voltage Ramp Rate | 0.5 | | 5 | ms |

3.7.8 Vision Processor D4 Board Thermals

The Vision Processor D4 Board should be screw mounted on to a heat sink or a heat dissipating structure element using screw forks on Board. Thermal conductive tape (electrically non-conductive) should cover the entire back side area (non-component side) of the ASIC Board for thermal transfer onto heat sink or heat dissipating structure element.

3.7.9 Vision Processor D4 Board Storage and Operating Conditions

Table 3-40. Vision Processor D4 Board Storage and Operating Conditions

| Condition | Description | Min | Max | Unit |
|---------------------------------------|--|-----------------------------|-----|------|
| Storage (Still Air), Not Operating | Temperature (Sustained, Controlled) ⁽¹⁾ | 0 | 40 | °C |
| | Temperature (Short Exposure) ⁽²⁾ | -40 | 70 | °C |
| | Humidity | Temperature/ RH: 40°C / 90% | | |
| Case Temperature ⁽³⁾⁽⁴⁾⁽⁵⁾ | Temperature | 0 | 50 | °C |

NOTE:

- (1) Controlled conditions should be used for long term storage of product.
- (2) Short exposure represents temporary max limits acceptable for transportation conditions.
- (3) Case temperature limits must be met for all operating temperatures.
- (4) Case temperature is specified for the overall Vision Processor D4 Board
- (5) Case temperature 0° minimum and lower temperatures is non-condensing

3.7.10 Intel® RealSense™ Vision Processor D4 Board Product Identifier and Material Code

Table 3-41. Vision Processor D4 Board Product Identifier and Material Code

| Production | Product Identifier Code-Manufacture Configuration Code | Product Material Code |
|---------------------------|--|-----------------------|
| Vision Processor D4 Board | J32139-120 | 952019 |

3.8 Intel® RealSense™ Depth Camera D400 Series

Figure 3-13. Intel® RealSense™ Depth Camera D415



Figure 3-14. Intel® RealSense™ Depth Camera D435/D435i



Table 3-42. Depth Camera SKU properties

| D400 series Depth Cameras | Intel® RealSense™ Depth Camera D415 | Intel® RealSense™ Depth Camera D435 | Intel® RealSense™ Depth Camera D435i |
|---------------------------|-------------------------------------|-------------------------------------|--------------------------------------|
| Depth module | Intel® RealSense™ Depth module D415 | Intel® RealSense™ Depth module D430 | Intel® RealSense™ Depth module D430 |
| Baseline | 55mm | 50mm | 50mm |
| Left/Right Imagers Type | Standard | Wide | Wide |
| Depth FOV HD (degrees) | H:65±2 / V:40±1 / D:72±2 | H:87±3 / V:58±1 / D:95±3 | H:87±3 / V:58±1 / D:95±3 |
| Depth FOV VGA (degrees) | H:50±2 / V:40±1 / D:61±2 | H:75±3 / V:62±1 / D:89±3 | H:75±3 / V:62±1 / D:89±3 |
| IR Projector | Standard | Wide | Wide |
| IR Projector FOV | H:67 / V:41 / D:75 | H:90 / V:63 / D:99 | H:90 / V:63 / D:99 |
| Color Sensor | OV2740 | OV2740 | OV2740 |
| Color Camera FOV | H:69±1 / V:42±1 / D:77±1 | H:69±1 / V:42±1 / D:77±1 | H:69±1 / V:42±1 / D:77±1 |
| IMU | NA | NA | 6DoF |

NOTE: H – Horizontal FOV, V – Vertical FOV, D – Diagonal FOV, X – Length, Y – Breadth, Z – Thickness

3.8.1 Depth Camera D400 Series Mechanical Dimensions

Table 3-43. Intel® RealSense™ Depth Camera D415 Mechanical Dimensions

| Dimension | Min | Nominal | Max | Unit |
|-----------|-----|---------|-----|------|
| Width | - | 99 | - | mm |
| Height | - | 23 | - | mm |
| Depth | - | 20 | - | mm |

| | | | | |
|--------|---|----|---|----|
| Weight | - | 72 | - | gr |
|--------|---|----|---|----|

Table 3-44. Intel® RealSense™ Depth Camera D435, D435i Mechanical Dimensions

| Dimension | Min | Nominal | Max | Unit |
|-----------|-----|---------|-----|------|
| Width | - | 90 | - | mm |
| Height | - | 25 | - | mm |
| Depth | - | 25 | - | mm |
| Weight | - | 72 | - | gr |

3.8.2 Depth Camera D400 Series Thermals

Table 3-45. Max Skin Temperature

| D400-Series Depth Cameras | Max Skin Temperature (25 degree C Ambient in Open Environment) |
|---------------------------|---|
| D415 | 44 °C |
| D435 | 44 °C |
| D435i | 44 °C |

3.8.3 Depth Camera D400 Series Storage and Operating Conditions

Table 3-46. Depth Camera D400 Series Storage and Operating Conditions

| Condition | Description | Min | Max | Unit |
|------------------------------------|--|-----------------------------|-----|------|
| Storage (Still Air), Not Operating | Temperature (Sustained, Controlled) ⁽¹⁾ | 0 | 40 | °C |
| | Temperature (Short Exposure) ⁽²⁾ | -40 | 70 | °C |
| | Humidity | Temperature/ RH: 40°C / 90% | | |
| Operating (Still Air) | Temperature | 0 | 35 | °C |

NOTE:

- (1) Controlled conditions should be used for long term storage of product.
- (2) Short exposure represents temporary max limits acceptable for transportation conditions.

3.8.4 Depth Camera D400 Series Product Identifier and Material Code

Table 3-47. Depth Camera D400 Series Product Identifier and Material Code

| Production | Product Identifier Code- Manufacture Configuration Code | Product Material Code |
|---------------------------------|--|-----------------------|
| Depth Camera D415 | J72476-100 | 961443 |
| Depth Camera D415 (Multi Pack) | J72476-100 | 962304 |
| Depth Camera D435 | J72479-100 | 961448 |
| Depth Camera D435 (Multi Pack) | J72479-100 | 962305 |
| Depth Camera D435i | K38179-100 | 999AFR |
| Depth Camera D435i (Multi Pack) | K38179-100 | 999AXG |

3.8.5 Camera Lens Cleaning Procedure

1. Do not use any chemical or water on the camera lens
2. Remove dust and dirt as much as possible from the lens with a lens blower brush.
3. Wipe with soft cloth or eyeglass lens wiper.

§§

4 Functional Specification

4.1 Vendor Identification (VID) and Device Identification (DID)

Table 4-1. Vendor ID and Device ID Table

| Depth Module/Depth Camera | Vendor ID | Device ID |
|--------------------------------------|-----------|-----------|
| Intel® RealSense™ Depth Module D400 | 8086 | 0x0AD1 |
| Intel® RealSense™ Depth Module D410 | 8086 | 0x0AD2 |
| Intel® RealSense™ Depth Module D415 | 8086 | 0x0AD3 |
| Intel® RealSense™ Depth Camera D415 | 8086 | 0x0AD3 |
| Intel® RealSense™ Depth Module D420 | 8086 | 0x0AF6 |
| Intel® RealSense™ Depth Module D430 | 8086 | 0x0AD4 |
| Intel® RealSense™ Depth Camera D435 | 8086 | 0x0B07 |
| Intel® RealSense™ Depth Camera D435i | 8086 | 0x0B3A |

4.2 Vision Processor D4 Data Streams

Intel® RealSense™ Vision Processor D4 Depth imaging system provides high quality depth data to a host system. The depth data is generated with stereo vision technology that is optionally assisted by an infrared projector. The imaging system has the ability to synchronize with color stream.

Table 4-2. Image Formats (USB 3.1 Gen1)

| Format | Resolution | Frame Rate (FPS) | Comment |
|-------------|------------|------------------|------------------------------------|
| Z [16 bits] | 1280x720 | 6,15,30 | Depth |
| | 848x480 | 6,15,30,60,90 | |
| | 640x480 | 6,15,30,60,90 | |
| | 640x360 | 6,15,30,60,90 | |
| | 480x270 | 6,15,30,60,90 | |
| | 424x240 | 6,15,30,60,90 | |
| Y8 [8 bits] | 1280x720 | 6,15,30 | Luminance Left and Right Imager |
| | 848x480 | 6,15,30,60,90 | |

| Format | Resolution | Frame Rate (FPS) | Comment |
|-----------------------|------------|------------------|---|
| | 640x480 | 6,15,30,60,90 | |
| | 640x360 | 6,15,30,60,90 | |
| | 480x270 | 6,15,30,60,90 | |
| | 424x240 | 6,15,30,60,90 | |
| UYVY [16 bits] | 1280x720 | 6,15,30 | Color Stream from Left Imager (D400, D410 & D415) |
| | 848x480 | 6,15,30,60,90 | |
| | 640x480 | 6,15,30,60,90 | |
| | 640x360 | 6,15,30,60,90 | |
| | 480x270 | 6,15,30,60,90 | |
| | 424x240 | 6,15,30,60,90 | |
| YUY2 [16 bits] | 1920x1080 | 6,15,30 | Color Stream from RGB camera (Camera D415 & D435/D435i) |
| | 1280x720 | 6,15,30 | |
| | 960x540 | 6,15,30,60 | |
| | 848x480 | 6,15,30,60 | |
| | 640x480 | 6,15,30,60 | |
| | 640x360 | 6,15,30,60 | |
| | 424x240 | 6,15,30,60 | |
| | 320x240 | 6,30,60 | |
| | 320x180 | 6,30,60 | |
| Calibration [24 bits] | 1920x1080 | 15,25 | D400/D410/D415 |
| | 1280x800 | 15,25 | D420/D430/D435/D435i |

NOTE:

Depth and Color are mapped as separated interfaces. Each one of the interfaces is working independent with the other interface (Virtual channel in MIPI and End Point in USB).

Table 4-3. Image Formats (USB 2.0)

| Format | Resolution | Frame Rate | Comment |
|----------------|------------|------------|---|
| Z [16 bits] | 1280x720 | 6 | Depth |
| | 640x480 | 6,15,30 | |
| | 480x270 | 6,15,30,60 | |
| Y8 [8 bits] | 1280x720 | 6 | Luminance Left and Right Imager |
| | 640x480 | 6,15,30 | |
| | 480x270 | 6,15,30,60 | |
| UYVY [16 bits] | 1280x720 | 6 | Color Stream from Left Imager (D410 & D415) |
| | 640x480 | 6,15,30 | |

| Format | Resolution | Frame Rate | Comment |
|----------------|------------|------------|---|
| | 480x270 | 6,15,30,60 | |
| YUY2 [16 bits] | 1280x720 | 6 | Color Stream from RGB camera (Camera D415 & D435/D435i) |
| | 640x480 | 6,15,30 | |
| | 424x240 | 6,15,30,60 | |

NOTE:

Depth and Color are mapped as separated interfaces. Each one of the interfaces is working independent with the other interface (Virtual channel in MIPI and End Point in USB).

Table 4-4. Simultaneous Image Streams (USB 3.1 Gen1 & USB2.0)

| Depth | Imager | Color (Left Imager) D400/D410 | Color (RGB Camera) D415/D435/D435i | IMU D435i | Comment |
|-------|--------|-------------------------------|------------------------------------|----------------------|---------|
| Z16 | Y8 | | | Gyro & Accelerometer | |
| Z16 | | UYVY | | Gyro & Accelerometer | |
| Z16 | Y8 | | YUV2 | Gyro & Accelerometer | |
| Z16 | | | YUV2 | Gyro & Accelerometer | |

NOTE:

1. RGB to depth hardware sync is only supported with the same frame rate for all streams.
2. For Depth and RGB camera simultaneous streaming, it is recommended to have color resolution to be the same or higher than depth resolution.
3. USB 3.1 Gen1 supports all resolution/frame rate combinations in a typical dedicated USB port configuration. On a USB hub with other devices (e.g. other RealSense cameras), considerations regarding bandwidth requirements have to be taken.
4. USB 2.0 supports a subset of the resolution/frame rate combinations given the bandwidth requirements.
 - Max. Depth Resolution Simultaneous Stream Configuration with Depth at 640X480, 15 FPS, Left Imager at 640X480, 15 FPS and RGB Camera at 640X480, 30 FPS.
 - Max. Depth Frame Rate Simultaneous Stream Configuration with Depth at 480X270, 60 FPS, Left Imager at 480X270, 60 FPS and RGB Camera at 424x240, 30 FPS

4.3 Depth Field of View (FOV)

The depth field of view is the common overlap of the individual left and right Imager field of view for which Vision Processor D4 provides depth data

Table 4-5. Depth Field of View

| Format | D400/D410/D415 | D420/D430/D435/D435i |
|--------------------------|----------------|----------------------|
| Horizontal FOV (VGA 4:3) | 48 | 74 |
| Vertical FOV (VGA 4:3) | 40 | 62 |
| Diagonal FOV (4:3) | 60 | 88 |
| Horizontal FOV (HD 16:9) | 64 | 86 |
| Vertical FOV (HD 16:9) | 41 | 57 |
| Diagonal FOV (HD 16:9) | 72 | 94 |

NOTE:

- Due to mechanical tolerances of +/-5%, Max and Min FOV values can vary from lens to lens and module to module by ~ +/- 3 degrees.
- The Depth FOV specified is at 2 meters distance.

4.4 Depth Field of View at Distance (Z)

Depth Field of View (Depth FOV) at any distance (Z) can be calculated using the equation

$$Depth\ FOV = \frac{HFOV}{2} + \tan^{-1}\left\{\tan\left(\frac{HFOV}{2}\right) - B/Z\right\}$$

Depth FOV = Depth Field of View

HFOV = Horizontal Field of View of Left Imager on Depth Module

B = Baseline

Z = Distance of Scene from Depth Module

Figure 4-1. Depth Field of View to Depth Map illustration

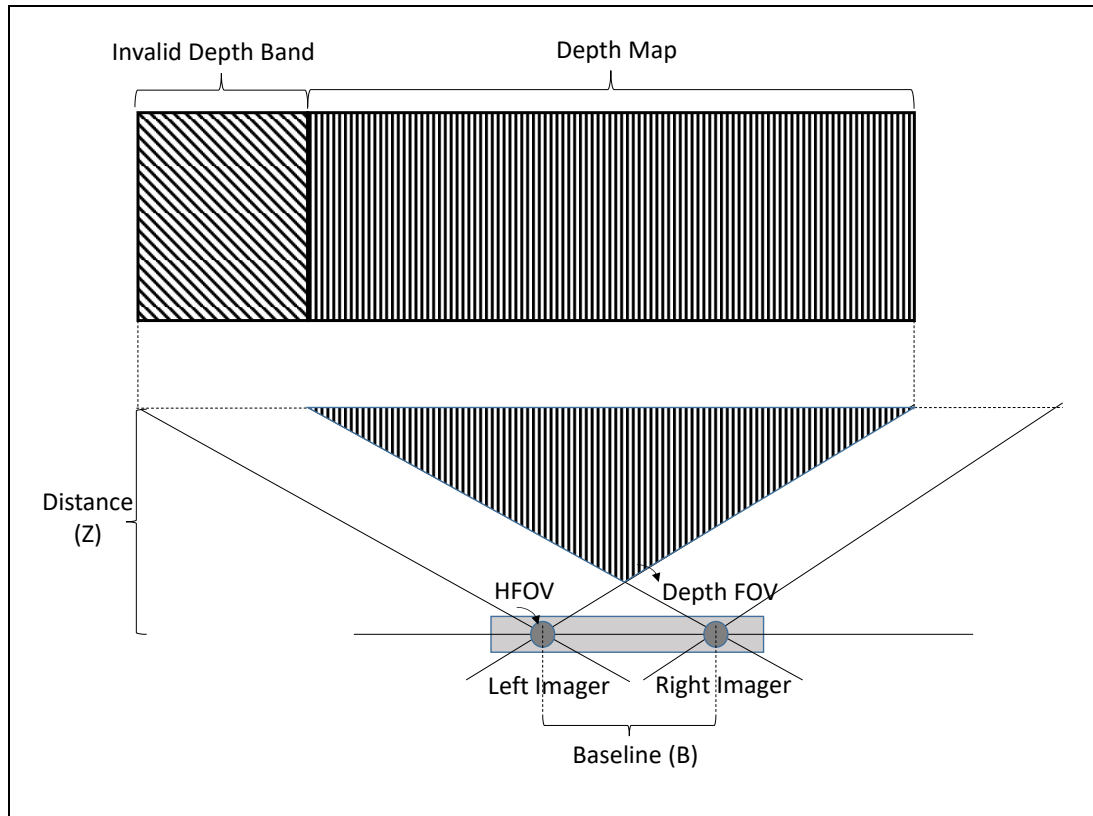

NOTES:

- As the scene distance from the depth module increases, the invalid depth band decreases in the overall depth image. Overall depth image is invalid depth band plus valid depth map.

4.5 Invalid Depth Band

The depth data generated with stereo vision uses the left imager as the reference for stereo matching resulting in a non-overlap region in the field of view of left and right imagers where we will not have depth data at the left edge of the frame. Closer scenes result in a wider invalid depth band than scenes at larger distances.

Figure 4-2. Left Invalid Depth Band

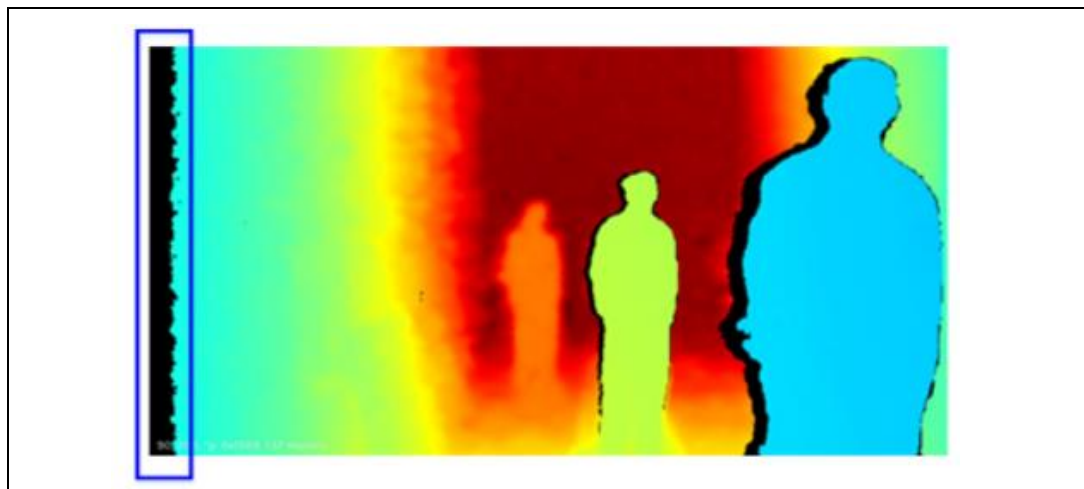

The width of the invalid depth band can be calculated using the following equations:

In terms of horizontal FOV

$$\begin{aligned}
 &DBR \text{ (Ratio of Invalid Depth Band to Total Horizontal Image)} \\
 &= B / (2 * Z * \tan(\frac{HFOV}{2}))
 \end{aligned}$$

$$\text{Invalid Depth Band (in Pixels)} = HRES * DBR$$

In terms of focal length

$$\begin{aligned}
 &DBR \text{ (Ratio of Invalid Depth Band to Total Horizontal Image)} \\
 &= B * F / (Z * HRES)
 \end{aligned}$$

$$\text{Invalid Depth Band (in Pixels)} = B * F / Z$$

B= Baseline

Z= Distance of Scene from Depth Module

F= Focal length

HFOV= Horizontal Field of View of Left Imager on Depth Module

HRES= Horizontal Resolution

The equations stand valid for a base configuration of camera settings. Default camera configuration in firmware may have settings optimized for depth performance that may impact the actual width of invalid depth band when compared to the calculated width of the invalid depth band from equations.

4.6 Minimum-Z Depth

The Minimum-Z Depth is the minimum distance from depth camera to scene for which Vision Processor D4 provides depth data.

Table 4-6. Minimum-Z Depth

| Resolution | D400/D410/D415 | D420/D430 |
|------------|----------------|------------|
| | Min-Z (mm) | Min-Z (mm) |
| 1280x720 | 450 | 280 |
| 848x480 | 310 | 195 |
| 640x480 | 310 | 175 |
| 640x360 | 240 | 150 |
| 480x270 | 180 | 120 |
| 424x240 | 160 | 105 |

4.7 Depth Quality Specification

There are a set of standard metrics based on accuracy, data validity, and temporal stability are used to quantify depth quality.

Although the module is designed for a certain depth FOV, the measurements are taken within 80% of this FOV, defined as region of interest (ROI). This ROI will best align with intended usage area and the optical parameters qualification field.

Table 4-7: Depth Quality Metric

| METRIC | DEFINITION ⁽¹⁾ |
|--|--|
| Depth Accuracy | Measure the difference for valid pixels relative to a ground truth surface. |
| Fill Rate | Percentage of pixels that have a valid depth value. |
| Depth Standard Deviation | Measures the total spatial noise for each valid pixel relative to a best fit plane. |
| Pixel Temporal Noise | Measures the total temporal noise for each valid pixel relative to a best fit plane. |
| NOTES: | |
| (1) Each measurement is taken from a predefined region of interest (ROI) which is within 80% of the depth field of view (FOV). | |

Table 4-8: Depth Quality Metric Illustration

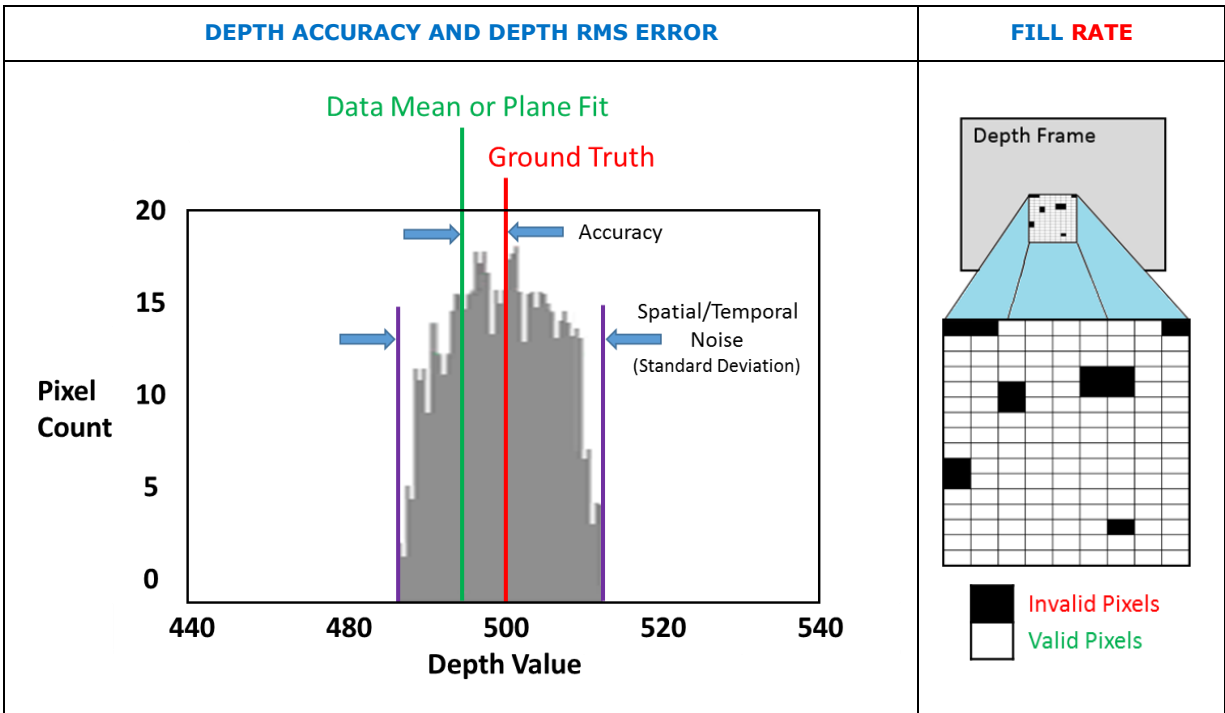

Table 4-9. Depth Quality Specification

| Metric | D400/D410/D415 (up to 2 Meters and 80% FOV) | D420/D430/D435/D435i (up to 2 Meters and 80% FOV) |
|--------------------------------|---|---|
| Z-accuracy (or absolute error) | ≤ 2% | ≤ 2% |
| Fill rate | ≥ 99% | ≥ 99% |
| RMS Error (or Spatial Noise) | ≤ 2% | ≤ 2% |
| Temporal Noise (Pixel) | ≤ 1% | ≤ 1% |

NOTES:

- 1) The Depth Quality spec applies to calibrated depth modules and depth cameras.
- 2) For Depth Quality metric definitions and test methodology, refer to white paper "Intel® RealSense™ Camera Depth Testing Methodology"
- 3) Laser Power: 150mW, Exposure: Auto Exposure

4.8 Measured Power

Table 4-10. Power- Ubuntu 16.04

| Model | Idle (W) | Normal Power (W) <i>Typical Usage Configuration</i> | Maximum Power (W) <i>Worst Case Configuration</i> |
|-------|----------|--|--|
| D400 | 0.04 | 1.44 | 1.44 |
| D410 | 0.05 | 1.71 | 2.21 |
| D420 | 0.04 | | 1.12 |
| D430 | 0.04 | | 2.68 |

Table 4-11. Power – Windows 10 (RS4)

| Model | Idle (W) | Normal Power (W) <i>Typical Usage Configuration</i> | Maximum Power (W) <i>Worst Case Configuration</i> |
|-------|----------|--|--|
| D400 | 0.04 | 1.44 | 1.44 |
| D410 | 0.04 | 1.84 | 2.51 |
| D420 | 0.04 | | 1.08 |
| D430 | 0.04 | | 2.85 |

NOTES:

1) Power Configuration:

(C) – Color Resolution

| Model | Configuration | Resolution | Frame Rate | Laser (IR) Power Setting | Comments |
|------------|---------------|----------------------------|------------|--------------------------|----------|
| D400 | Typical | 1280X720 | 30FPS | 0mW | |
| | Worst Case | 1280X720 | 30FPS | 0mW | |
| D410 | Typical | 1280X720 | 30FPS | 150mW | |
| | Worst Case | 1280X720 | 30FPS | 330mW | |
| D415 | Typical | 1280X720/ 1280X720 (C) | 30FPS | 150mW | |
| | Worst Case | 1280X720/ 1920X1080 (C) | 30FPS | 330mW | |
| D420 | Typical | 848X480 | 30FPS | 0mW | |
| | Worst Case | 1280X720 | 30FPS | 0mW | |
| D430 | Typical | 848X480 | 30FPS | 150mW | |
| | Worst Case | 1280X720 | 30FPS | 330mW | |
| D435/D435i | Typical | 848X480/ 1280X720 (C) | 30FPS | 150mW | |

| | | | | | |
|--|------------|----------------------------|-------|-------|--|
| | Worst Case | 1280X720/ 1920x1080 (C) | 30FPS | 330mW | |
|--|------------|----------------------------|-------|-------|--|

4.9 Depth Start Point (Ground Zero Reference)

The depth start point or the ground zero reference can be described as the starting point or plane where depth = 0. For depth modules (D400, D410 & D415), this point is referenced from front of lens or from backside of module. For depth cameras (D415 and D435/D435i), this point is referenced from front of camera cover glass

Figure 4-3. Depth Module Depth Start Point Reference

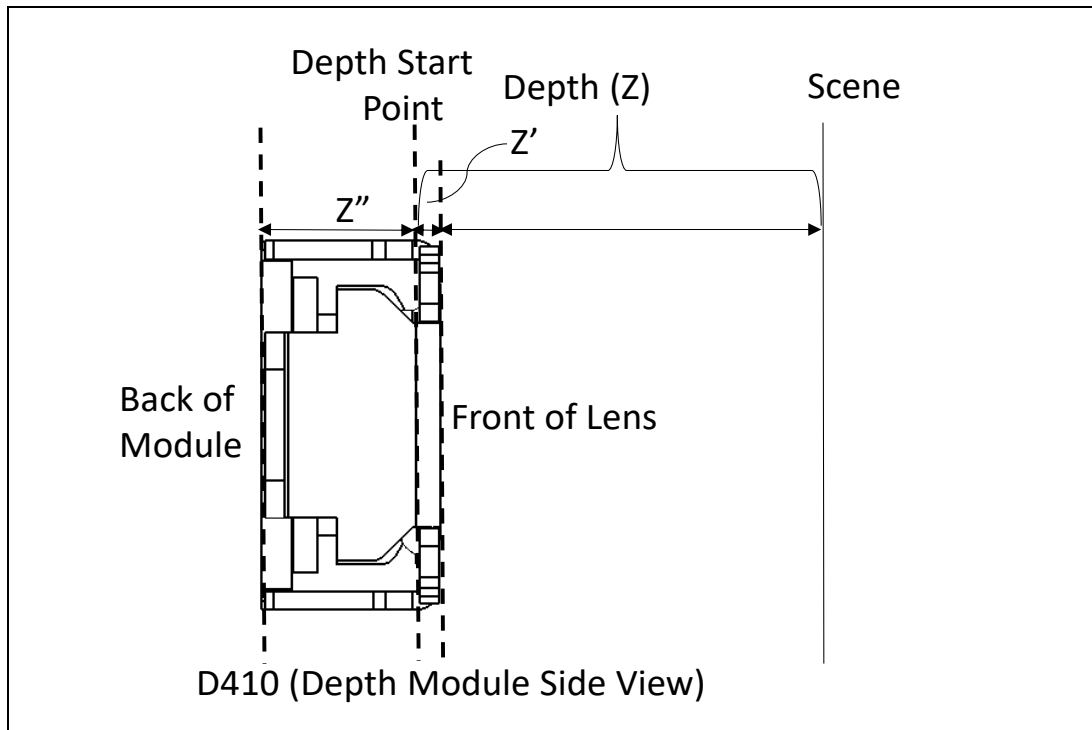

Table 4-12. Depth Module Depth Start Point

| Depth Module | Front of Lens (Z') | Back of Module (Z'') |
|----------------|--------------------|----------------------|
| D400/D410/D415 | -0.1mm | 4.3mm |
| D420/D430 | -3.2mm | 7.5mm |

NOTES:

If depth measurement reference is front of lens, then |Z'| should be added to measured value to determine Ground Truth. If depth measurement reference is back of module, then |Z''| should be subtracted to determine Ground Truth.

Figure 4-4. Depth Camera Depth Start Point Reference

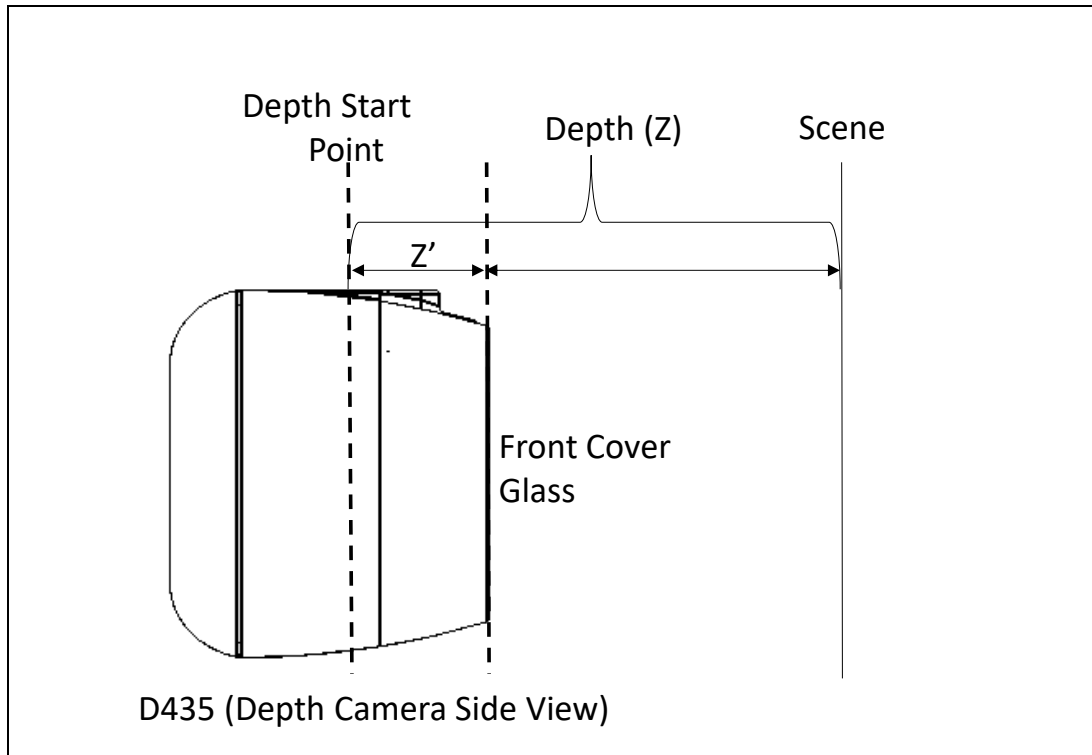

Table 4-13. Depth Cameras Depth Start Point

| Depth Camera | Camera Front Glass (Z') |
|--------------|-----------------------------|
| D415 | -1.1mm |
| D435/D435i | -4.2mm |

NOTES:

If depth measurement reference is front cover glass, then $|Z'|$ should be added to measured value to determine Ground Truth.

4.9.1 Depth Origin X-Y Coordinates

The depth origin X-Y coordinates is the X-Y center of left imager.

Figure 4-5. Depth Module X-Y Depth Origin Reference

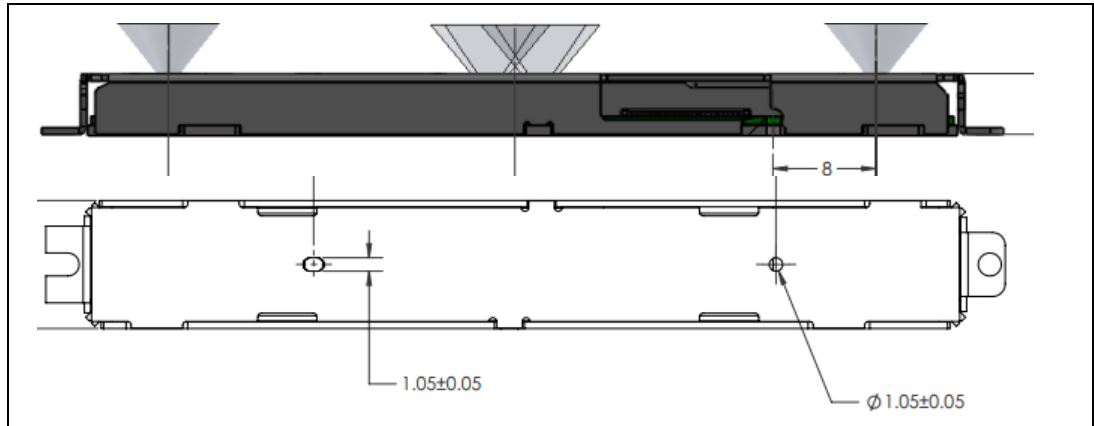

Table 4-14. Depth Module X-Y Depth Origin Coordinates

| Depth Module | Left Alignment hole ¹ to Left imager Center |
|--------------|--|
| D400 | 8mm |
| D410 | 8mm |
| D415 | 8mm |
| D420 | 8mm |
| D430 | 8mm |

NOTES:

1. Left alignment hole on bottom stiffener of depth module
2. Left alignment hole and left imager center is on depth module centerline.

Figure 4-6. Depth Camera X-Y Depth Origin Reference

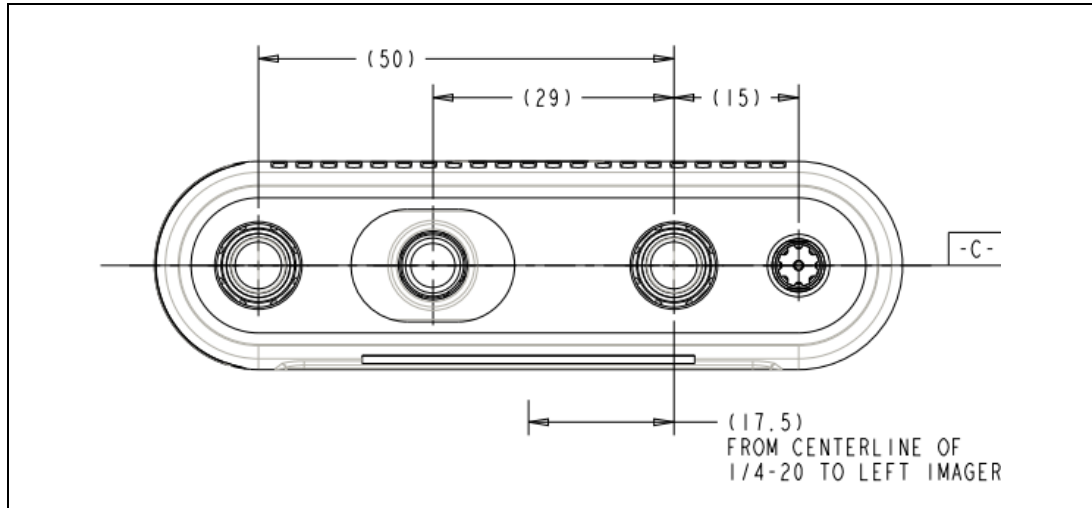

Table 4-15. Depth Camera X-Y Depth Origin Coordinates

| Depth Camera | From Centerline of 1/4-20 ¹ To Left Imager |
|--------------|---|
| D415 | 20mm |
| D435/D435i | 17.5mm |

NOTES:

- Center of tripod mounting hole (1/4-20)

4.10 Depth Camera Functions

D4 exposes the following Depth image settings.

Table 4-16. Depth Camera Controls

| Control | Description | Min | Max |
|---|--|-----|-----|
| Manual Exposure ⁽¹⁾ (ms) | Control sensor exposure period (400/410) | 1 | 166 |
| Manual Exposure ⁽¹⁾ (ms) | Control sensor exposure period (430) | 1 | 166 |
| Manual gain ⁽¹⁾ (Gain 1.0 = 16) | Control sensor digital gain. | 16 | 248 |
| Laser Power (on/off) (On = 1) | Power to IR Projector | 0 | 1 |
| Manual Laser Power (mW) | Laser Power setting (30mW steps) | 0 | 360 |

| Control | Description | Min | Max |
|---------------------------------|---|--------------------------|------------------------------------|
| Auto Exposure Mode (Enable = 1) | Auto Exposure Mode. When Auto Exposure is enabled, Exposure and Gain are set based on the environment condition | 0 | 1 |
| Auto Exposure ROI | Perform Auto Exposure on a selected ROI | T-0 L-0 B-1 R-1 | T-719 L-1279 B-720 R-1280 |
| Preset | Set Controls parameters based on Camera Usage | | |
| Meta Data Control | Enable/Disable Metadata | 0 | 1 |

NOTES:

(1) – Not supported in Auto Exposure Mode

T - Top, L – Left, B - Bottom, R – Right

4.11 Color Camera Functions

Table 4-17. RGB Exposed Controls

| Control | Description | Min | Max |
|-----------------------------------|--|------|-------|
| Auto-Exposure Mode | Automatically sets the exposure time and gain for the frame. | 0x1 | 0x8 |
| Manual Exposure Time | Sets the absolute exposure time when auto-exposure is disabled. | 41 | 10000 |
| Brightness | Sets the amount of brightness applied when auto-exposure is enabled. | -64 | 64 |
| Contrast | Sets the amount of contrast based on the brightness of the scene. | 0 | 100 |
| Gain | Sets the amount of gain applied to the frame if auto-exposure is disabled. | 0 | 128 |
| Hue | Sets the amount of hue adjustment applied to the frame. | -180 | 180 |
| Saturation | Sets the amount of saturation adjustment applied to the frame. | 0 | 100 |
| Sharpness | Sets the amount of sharpening adjustment applied to the frame. | 0 | 100 |
| Gamma | Sets amount of gamma correction applied to the frame. | 100 | 500 |
| White Balance Temperature Control | Sets the white balance when AWB is disabled. | 2800 | 6500 |

| Control | Description | Min | Max |
|--------------------------------------|--|-----|-----|
| White Balance Temperature Auto (AWB) | Enables or disables the AWB algorithm. | 0 | 1 |
| Power Line Frequency | Specified based on the local power line frequency for flicker avoidance. | 0 | 3 |
| Backlight Compensation | Sets a weighting amount based on brightness to the frame. | 0 | 1 |
| Low Light Comp | Low Light Compensation | 0 | 1 |

4.12 IMU Specifications

Table 4-18. IMU Specifications

| Camera | Parameter | Properties |
|--|--|----------------|
| Intel® RealSense™ Depth Camera D435i (D435 + BMI055) | Degrees of Freedom | 6 |
| | Acceleration Range | ±4g |
| | Accelerometer Sample Rate ¹ | 62.5, 250 (Hz) |
| | Gyroscope Range | ±1000 deg/s |
| | Gyroscope Sample Rate ² | 200, 400 (Hz) |
| | Sample Timestamp Accuracy | 50 usec |

NOTES:

1. The sample rate may differ from the absolute specified sample rate by ±5%. It is advised to rely on the sample timestamp.
2. The sample rate may differ from the absolute specified sample rate by ±0.3%.

§§

5 Firmware

The firmware contains the operation instructions. Upon runtime, Vision Processor D4 loads the firmware and programs the component registers. If the Vision Processor D4 is configured for update or recovery, the unlocked R/W region of the firmware can be changed.

5.1 Update

During a firmware update, the firmware utility will issue a device firmware update command to the Vision Processor D4. The Vision Processor D4 will then reset into firmware update mode. The firmware utility uses a single binary file to maintain the firmware image. The firmware utility compares the firmware version installed on the camera to the firmware version file to be updated. Based on the comparison, the firmware utility will downgrade, upgrade, or skip if the versions match.

5.1.1 Update Limits

The firmware update engine does not allow infinite update cycles between older and current versions of firmware. The engine will establish a baseline version of firmware based on the latest firmware version installed. The engine will allow a return to a previous version or baseline version of firmware up to 20 times. After the 20th update, the engine will only allow an update to a firmware revision higher than the baseline version.

5.2 Recovery

A read only boot sector is built into firmware which enables basic operation regardless of the integrity of the operation instructions region. This ensures the imaging system can function in the case of firmware not be written properly. When a firmware recovery is required, the firmware utility will communicate with the recovery driver to set the DFU pin low and reset the imaging system in recovery mode.

Firmware Recovery can also be externally triggered by having controllable interrupt connected to the Vision Processor D4 DFU (Device Firmware Update) pin.

The firmware recovery sequence will be triggered by the firmware client utility. This client utility will communicate through ACPI _DSM to trigger the controllable interrupt (GPIO) at the appropriate times. The firmware recovery requires an ACPI _DSM interface to control the interrupt GPIO in configuring to firmware recovery state. The _DSM methods and BIOS use the Write to GPIO functions to set the controllable interrupt.



6 Software

6.1 Intel® RealSense™ Software Development Kit 2.0

Intel® RealSense™ SDK 2.0 is a cross-platform library for working with Intel® RealSense™ D400 Series. It is open source and available on <https://github.com/IntelRealSense/librealsense>

The SDK at a minimum includes:

- **Intel® RealSense™ Viewer** - This application can be used view, record and playback depth streams, set camera configurations and other controls.
- **Depth Quality Tool** - This application can be used to test depth quality, including: distance to plane accuracy, Z accuracy, standard deviation of the Z accuracy and fill rate.
- **Debug Tools** - These command line tools gather data and generate logs to assist in debug of camera.
- **Code Examples** - Examples to demonstrate the use of SDK to include D400 Series camera code snippets into applications.
- **Wrappers** -Software wrappers supporting common programming languages and environments such as ROS, Python, Matlab, node.js, LabVIEW, OpenCV, PCL, .NET and more

§§

7 System Integration

The small size of the stereo depth module and the separate placement of Vision Processor D4 provides system integrators flexibility to design into a wide range of products. Because the camera uses stereo vision technology, it is crucial that the stereo depth module does not flex throughout its service life. This creates unique mechanical and thermal implementation guidance. This section explains how to correctly integrate D4 depth camera into a system

7.1 System Level Block Diagram

Figure 7-1. System Block Diagram

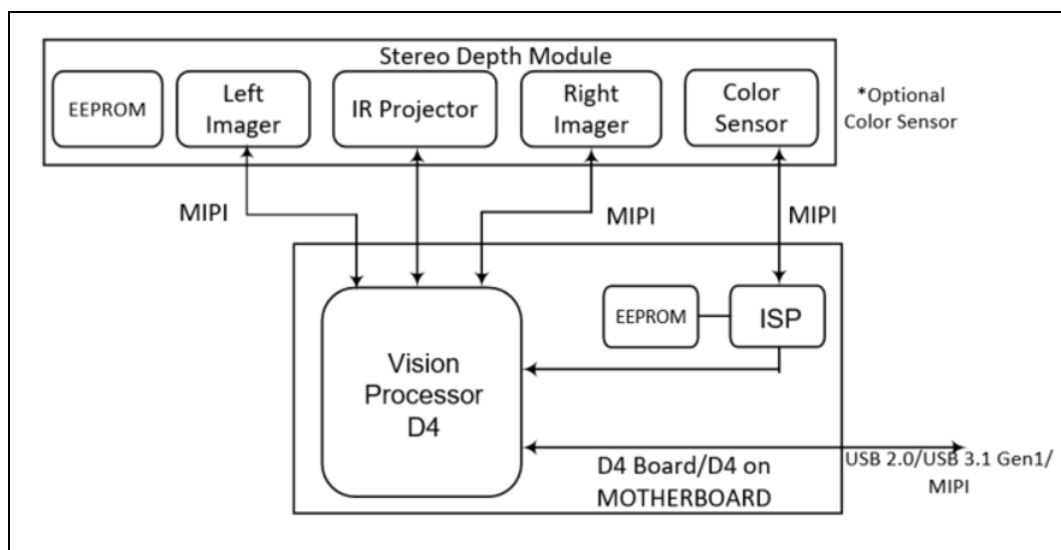

7.2 Vision Processor D4 System Integration

There are two options to integrate Vision Processor D4 into a system, either by integration of Vision Processor D4 Board or having the Vision Processor D4 and support components directly on the host processor motherboard. Vision Processor D4 Board simplifies system design and integration of the D4 depth camera system and Vision Processor D4 on Motherboard allows for a space optimized implementation of the D4 depth camera system.

7.2.1 Vision Processor D4 Board

The Vision Processor D4 Board has a standard USB Type-C connector and requires an appropriate USB Type-C cable to connect to a standard USB 2.0/USB 3.1 Gen 1 external port.

Figure 7-2. Intel® RealSense™ Vision Processor D4 Board

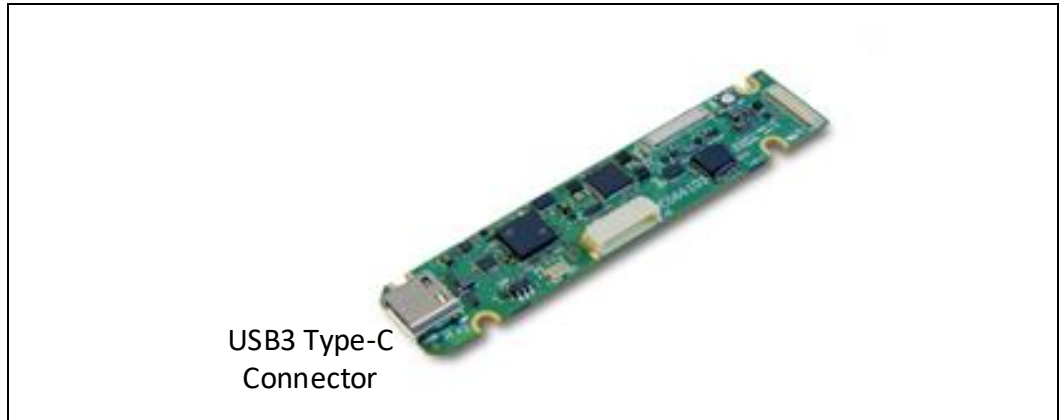

7.2.2 Vision Processor D4 on Motherboard

In the Vision Processor D4 on Motherboard option, Vision Processor D4 and support components are directly placed on the host processor motherboard. The depth module receptacle is on the host processor motherboard for connection to the stereo depth module.

Figure 7-3. Vision Processor D4 on Motherboard (Illustration)

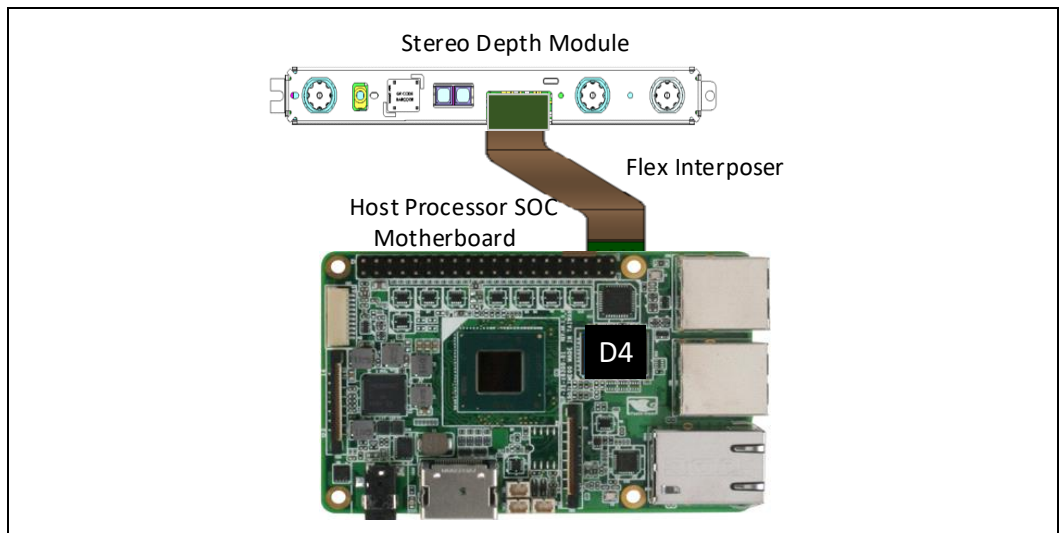

7.2.2.1 Firmware Update

SPI flash chip assembled onto the motherboard requires a bootable firmware image for Vision Processor D4 to boot or to run the firmware update utility provided by Intel.

There are two options program flash with firmware image or to recover a corrupt firmware image.

1. Pre-program SPI flash chip with firmware before assembly on to motherboard or replace corrupt image with a good image SPI flash chip. The blank SPI flash chip can pre-programmed using a compatible adapter (i.e. PA8QFN8D) and supporting flash programmer.
2. A header or test points is connected in parallel to the SPI flash chip, then programmed directly with an SPI flash programmer. Vision Processor D4 SPI interface is put in high Z state by strapping EPGPIO4 pin to Ground when programmed directly with an SPI flash programmer.

7.3 D4 Camera System Power Delivery

D4 camera system **MUST** keep stereo depth module and the Vision Processor D4 on the same power rails. The stereo depth module holds a safety region in EEPROM that is configured by firmware protected region. Keeping all components on the same rail prevents malicious software reset of the stereo depth module without causing a reset to the ASIC. By this protection we make sure that all the safety logic is kept locked as long as the device is active. Ensure power delivery implementation recommendation in Chapter 12 are followed in the design of D4 camera system.

Figure 7-4. D4 Camera System Power Scheme

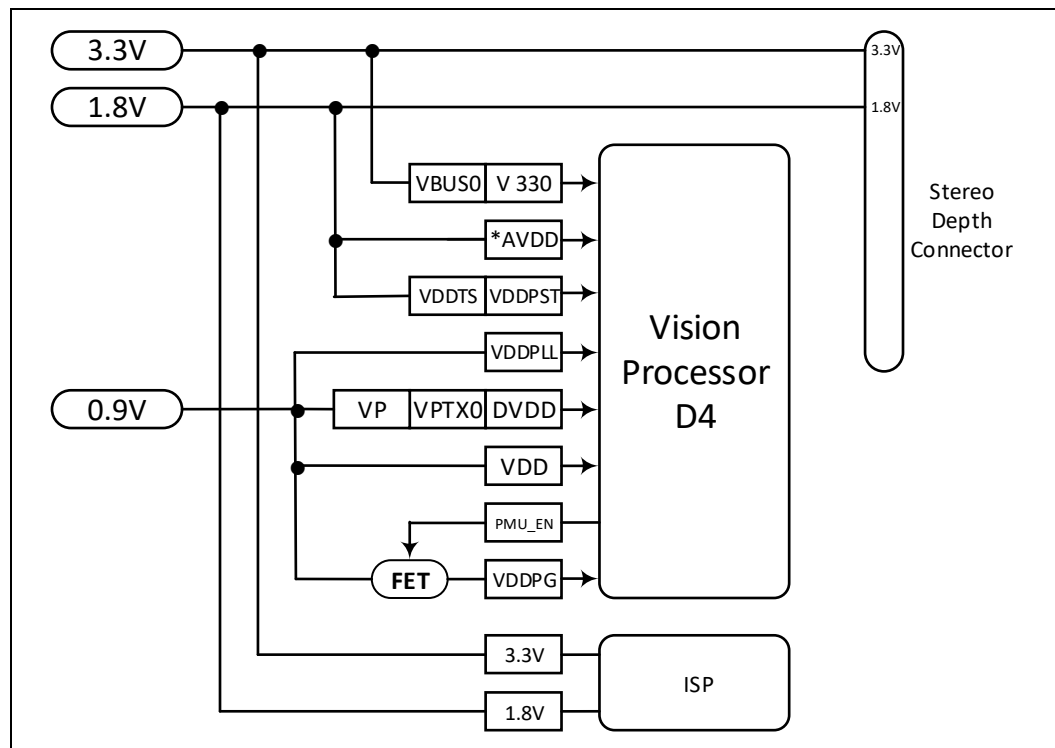

7.4 Vision Processor D4 Board for Integrated Peripheral

In design of custom host processor motherboard with custom Vision Processor D4 Board for embedded applications, a low mechanical profile 10 pin USB 3.1 Gen 1 receptacle can be implemented on motherboard and Vision Processor D4 Board.

7.4.1 USB 3.1 Gen 1 Receptacle

Table 7-1. USB 3.1 Gen 1 Receptacle Characteristics

| PROPERTY | DESCRIPTION | DIAGRAM |
|----------------|---------------------|---|
| Shell Finish | Tin (Sn) |  |
| Lock | Yes | |
| Ground Bar | Yes | |
| Alignment Boss | No | |
| Part Number | IPEX 20347-310E-12R | |

Table 7-2. USB 3.1 Gen 1 Receptacle Pin Out

| POSITION | NAME | TYPE | DESCRIPTION |
|----------|------------------------|------|------------------------------------|
| 1 | GND | - | Ground |
| 2 | USB3_SS _{TX-} | OUT | USB 3.1 Gen 1 Transmitter Negative |
| 3 | USB3_SS _{TX+} | OUT | USB 3.1 Gen 1 Transmitter Positive |
| 4 | GND | - | Ground |
| 5 | USB3_SS _{RX-} | IN | USB 3.1 Gen 1 Receiver Negative |
| 6 | USB3_SS _{RX+} | IN | USB 3.1 Gen 1 Receiver Positive |
| 7 | GND | - | Ground |
| 8 | DFU | IN | Device Firmware Update |
| 9 | 3.3V | - | Supply Voltage, Connect to 3.3V |
| 10 | 3.3V | - | Supply Voltage, Connect to 3.3V |

7.4.2 USB 3.1 Gen 1 High Speed Cable Assembly

The high speed cable assembly is developed and procured by the system integrator. The cable assembly design is specific to the system definition and must meet cable assembly design specification.

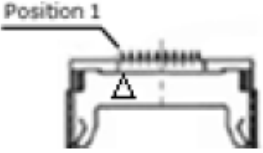
Table 7-3. USB 3.1 Gen 1 Plug Characteristics

| PROPERTY | DESCRIPTION | DIAGRAM |
|--------------|-------------|---------|
| Shell Finish | Tin (Sn) | |

| | | |
|---------------------|--------------------|--|
| Friction Lock | Yes | |
| Ground Bar | Yes | |
| Plug Part Number | IPEX 2047-0103 | |
| Housing Part Number | IPEX 20346-010T-31 | |

Table 7-4. Cable Assembly Specification

| PROPERTY | DESCRIPTION |
|----------------------|---|
| Cable Length | 15 inches (max) |
| Controlled Impedance | 85 Ohms with a tolerance of ± 10%. |
| Max Insertion Loss | <= 7.5 dB @2.5GHz |
| Cable Shielding | Each plug connected to the receptacle shield and GND bar. |

The Transmit to receive pair crossover is expected on the Motherboard and not the cable assembly. This is done to allow for flat cable assemblies.

7.4.3 Transmit to Receive Crossover

The host USB 3.1 Gen 1 transmit signals must be connected to the Vision Processor D4 USB 3.1 Gen 1 receive signals. The host USB 3.1 Gen 1 receive signals must be connected to the Vision Processor D4 USB 3.1 Gen 1 transmit signals. It is recommended not to cross over the signals in the cable to allow cable wiring to be flat and as thin as possible.

Figure 7-5. Host Motherboard USB 3.1 Gen 1 Routing

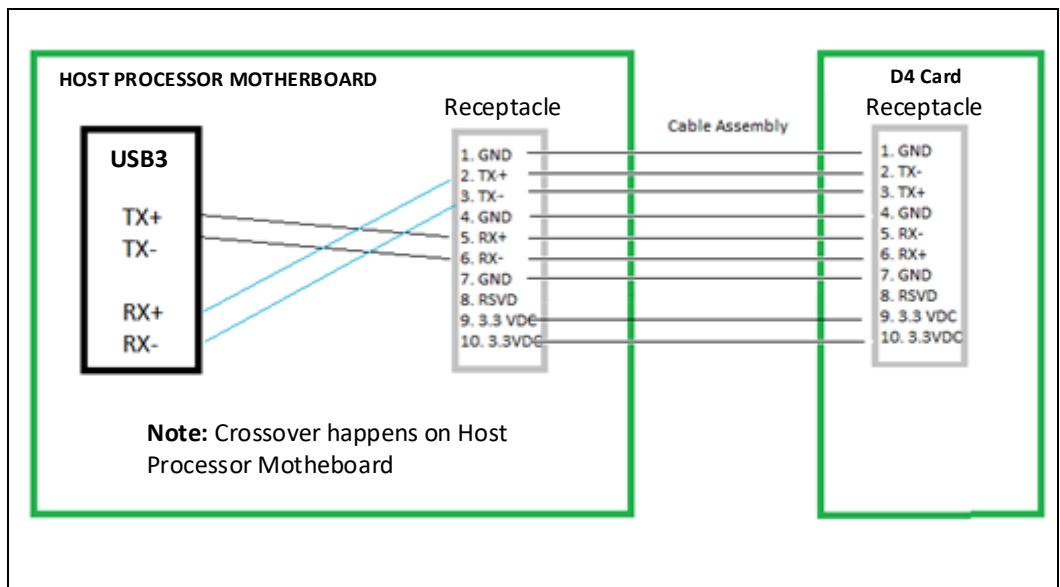

7.4.4 Motherboard Receptacle

Table 7-5. Motherboard Receptacle Properties

| PIN | WIRE DESCRIPTION |
|-----------|--|
| Shielding | Metal shielding, connected to GND plane. |
| Grounding | Two ground bar connections in addition to the connector GND. |

It is recommended that the motherboard receptacle be grounded as well as ground bar pads implemented.

Figure 7-6. Receptacle Ground Bar Motherboard Connections

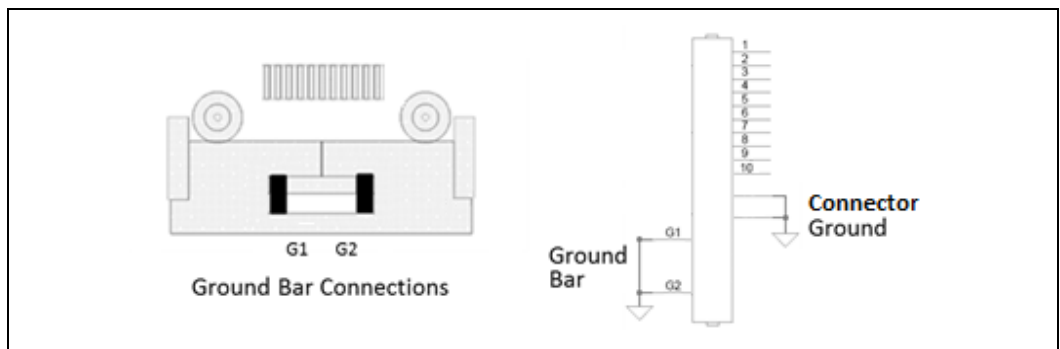

7.4.5 Vision Processor D4 Board for Integrated Peripheral Power Requirements

The Vision Processor D4 Board is powered by 5V from host processor motherboard through USB 3.1 Gen 1 receptacle pins 9 and 10

Table 7-6. Vision Processor D4 Board as Embedded Peripheral Power Requirements

| Parameter | Min | Nom | Max | Unit |
|-----------|----------------|-------|-----|------|
| VCC | Supply Voltage | +/-5% | 5V | V |
| ICC | Supply Current | | 700 | mA |

7.5 Thermals

The system thermal design must ensure the component case temperature are not exceeded. Thermal models for Vision Processor D4 board and Depth modules are available to conduct a thermal evaluation and validate the system thermal design.

Table 7-7. Vision Processor D4 Board – Component Power and TDP at Max Operating Mode⁽¹⁾

| Component | Power | TDP | Unit |
|--------------------------|---------|---------|------|
| Vision Processor D4 | 618 | 618 | mW |
| Color Camera ISP | 196.83 | 196.83 | mW |
| Voltage Regulators/Other | 491.64 | 491.64 | mW |
| All Components | 1306.47 | 1306.47 | mW |

Table 7-8. Stereo Depth Module (Standard) – Component Power and TDP at Max Operating Mode⁽¹⁾

| Component | Power | TDP | Unit |
|-------------------------|--------|--------------------|------|
| Left Imager | 118.5 | 118.5 | mW |
| Right Imager | 118.5 | 118.5 | mW |
| IR Projector | 1296 | 946 ⁽²⁾ | mW |
| Color Sensor | 118.5 | 118.5 | mW |
| EEPROM + Thermal Sensor | 4 | 4 | mW |
| All Components | 1655.5 | 1305.5 | mW |

Table 7-9. Stereo Depth Module (Wide) – Component Power and TDP at Max Operating Mode⁽¹⁾

| Component | Power | TDP | Unit |
|-------------------------|-------|---------------------|------|
| Left Imager | 177 | 177 | mW |
| Right Imager | 177 | 177 | mW |
| IR Projector | 1620 | 1260 ⁽²⁾ | mW |
| EEPROM + Thermal Sensor | 4 | 4 | mW |
| All Components | 1978 | 1618 | mW |

1. Max. Operating Mode – Depth Resolution 1280X720 30FPS, Color Resolution - 1920X1080p 30FPS
2. The IR projector TDP is lower than power due to a percentage of energy dissipated as photonic emissions rather than heat.
3. Voltage Regulator power is included as part of the individual component power

Table 7-10. Vision Processor D4 Board Components – Case Temperature Limits (Still Air)

| Component | Min | Max ⁽¹⁾ | Unit |
|---------------------|-----|--------------------|------|
| Vision Processor D4 | 0 | 110 | °C |
| Color Camera ISP | 0 | 70 | °C |

For the Depth Modules, case temperature is specified for the overall depth module and the thermocouple test location is any point on bottom metal stiffener

Figure 7-7. Bottom Stiffener Depth Module D410

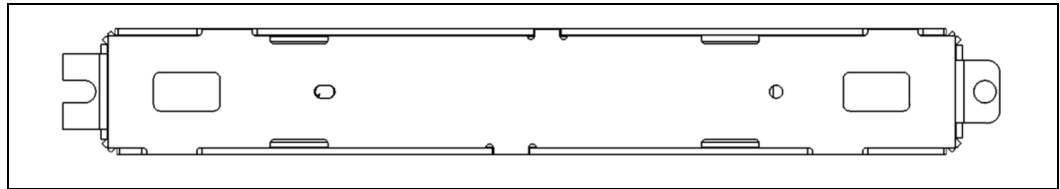
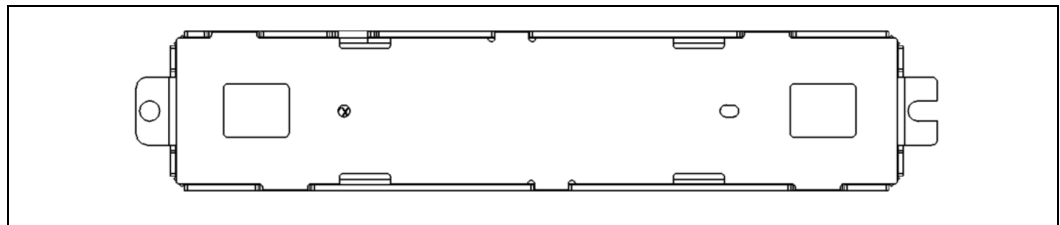

Figure 7-8. Bottom Stiffener Depth Module D430



7.6 Stereo Depth Module Flex

It is critical that stereo depth module does not experience flex during system integration or during use after integration. Micron level flexing of the module can render the calibration incorrect and will result in poor performance or nonfunctional depth data. It is important for system designers to isolate the module from any chassis flex the system may encounter. While the module has a reinforcement housing, the housing is not intended to counter loads from chassis flex. The primary function of the housing is to prevent loss of calibration from handling and operating environments.

It is possible for the module to recover depth performance after experiencing permanent deformation. However, the module's ability to recover is dependent on the amount of deformation experienced.

7.7 Stereo Depth Module Mounting Guidance

7.7.1 Screw Mount

The stereo depth module incorporates a screw hole and a screw fork for module mounting. The stereo depth module should be mounted on a large heat sink or a heat dissipating structure element using M1.6 screw at the screw hole and fork. The recommended torque for both screws is 1.6Kg*cm. Thermal interface material should be used on backside region of IR projector and two stereo imagers between camera module and heat sink or heat dissipating structure element for thermal transfer.

Figure 7-9. Stereo Depth Module Screw Mount

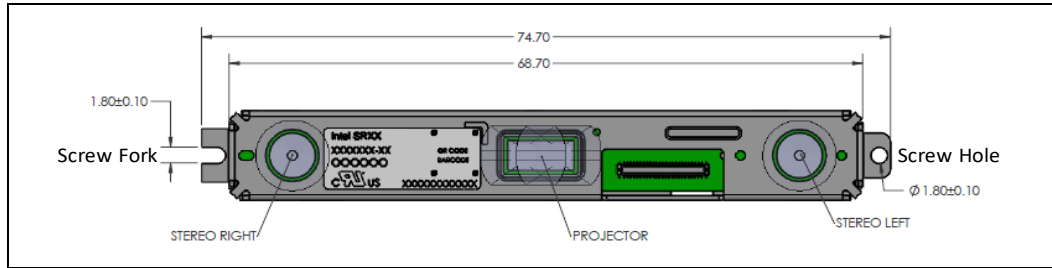

7.7.2 Bracket Mount

The Stereo Depth module should be mounted on large heat sink or a heat dissipating structure element using the bracket placed at the center of module. The bracket is made up of 0.35mm thickness stainless steel. The bracket is secured to the heat sink or structure element using two M1.6 screws with recommended torque of 1.6Kgf*cm. The rectangular (400/410 bracket) or circular (430 bracket) cutout is for thermal interface filler or as IR Projector opening when reversing bracket to mount. Thermal interface material should be used on backside region of IR projector and two stereo imagers between camera module and heat sink or heat dissipating structure element for thermal transfer. The camera module should have a minimum of 0.2mm clearance from all sides except for the area around bracket. It is not required to have screws at the screw hole and screw fork at both ends of module when mounting camera module using bracket.

Figure 7-10. Stereo Depth Module Bracket

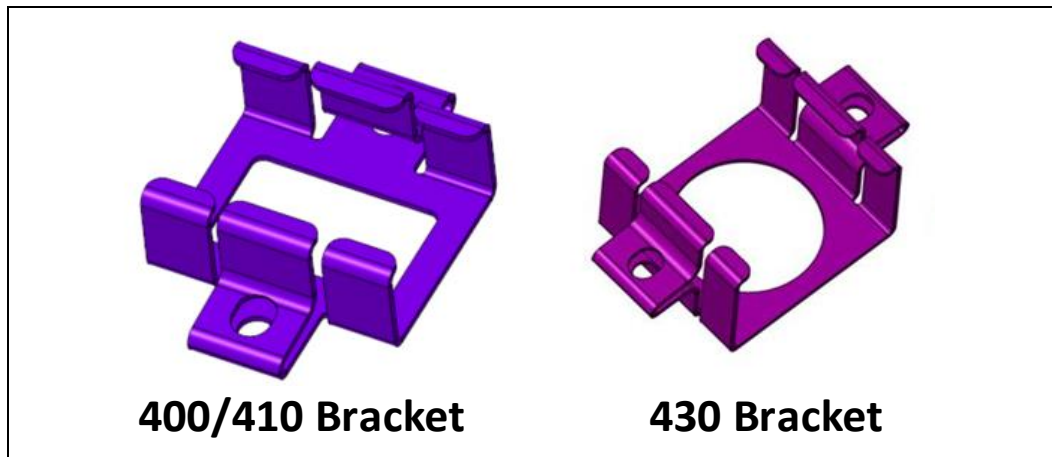

Figure 7-11. Stereo Depth Module Bracket Mount

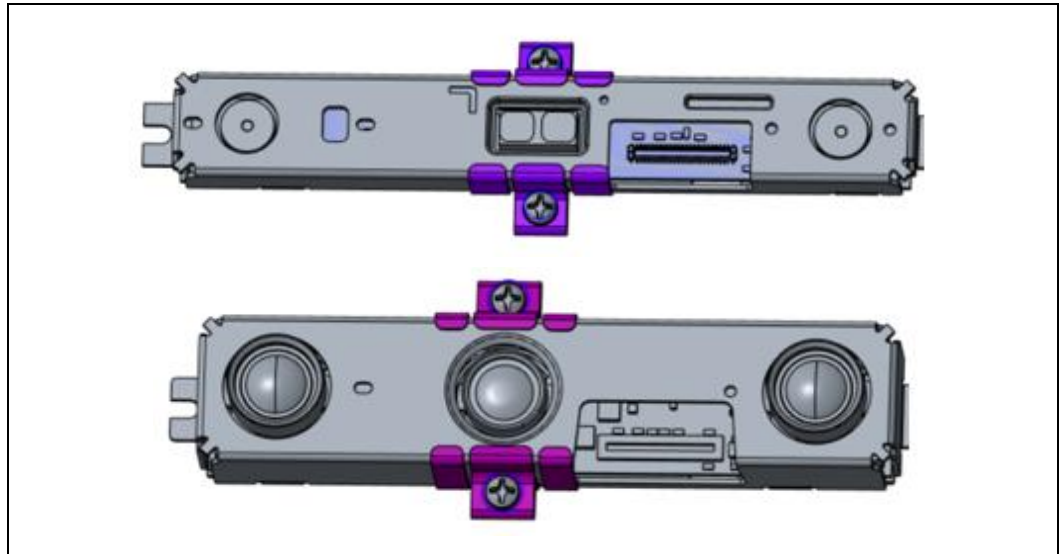

Figure 7-12. Stereo Depth Module Bracket Install

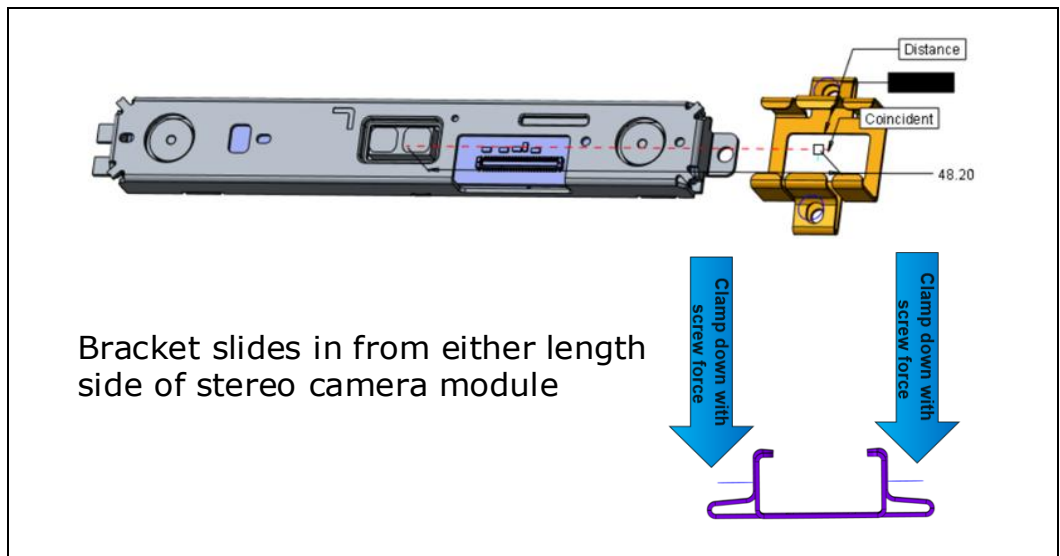

Table 7-11. Bracket Ordering Logistics

| Vendor | Sales Contact |
|---------------------------|---|
| FASPRO Technologies, INC. | Chuck Drews chuck@acuproinc.com www.fasprotech.com (M) 847-612-2350 (O) 224-848-4131 |

7.7.3 Stereo Depth Module Air gap

A minimum 0.3mm air gap is recommended between highest components on the stereo depth module to the cover window

Figure 7-13. Stereo Depth Module Air Gap

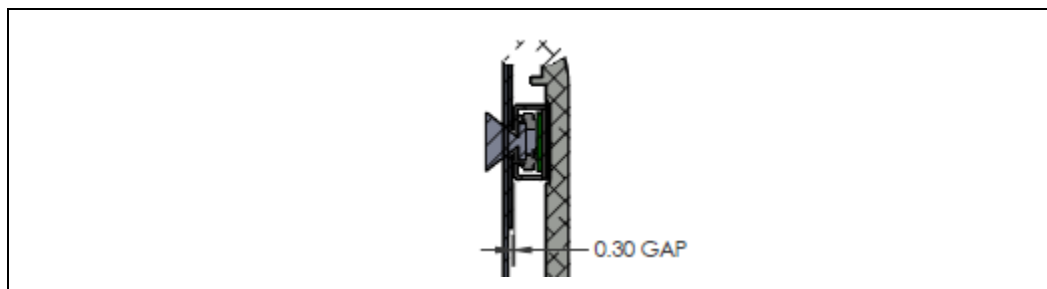

7.8 Thermal Interface Material

Thermal interface material, specifically thermal paste/grease is recommended to be inserted between the stereo depth module and the heat dissipating structure (heat sink) to improve the thermal coupling between these two components. A thermal paste with thermal conductivity in the 3-4W/mK range is recommended. This paste must be applied in a thin layer on the back side of the IR projector and also under the left and right imagers filling up the air gap under the Imagers.

7.9 Heat Sink

The heat sink or heat dissipating structure element used to mount stereo depth module and ASIC Board should be a minimum of 2-3mm in thickness. It is advisable to extend the heat sink by a few mm beyond the edges of the stereo depth module. It is also recommended to have thermal fins on the back side of the heat dissipating structure. In applications where weight is a concern, high thermal conductivity graphite tape can be attached to the back side of the heat sink. This graphite tape must be at least as big as the metal heat sink and extended out beyond the metal as much as possible for optimal cooling. Heat sink metal must be a high conductivity aluminum alloy or copper.

In cases where the module is expected to operate at high ambient temperatures, additional airflow may be required to ensure temperature limits are not exceeded. These are guidelines for thermal integration of the D4 camera in the system, however actual testing or system level thermal modeling is recommended before finalizing solution.

7.10 Cover Design and Material Guidance

The stereo depth module components must be covered to minimize dust and humidity. The transparent cover material stack-up used must provide acceptable transmission based on the component wavelengths. Anti-reflective coatings can help increase the transmission of cover material. Cover material that reduces light transmission can result in poor depth performance and will decrease the working

range of the camera. Nominally flat, non-distorting and low scattering cover material should be used.

Table 7-12. Component Transmission

| Component | Wavelength | Unit |
|---|--|------|
| Left and Right Imager (Intel® RealSense™ D410/D430) | 400 to 865 (Visible and Infrared) @ 98% transmission rate or higher at all viewing and transmitting angles | nm |
| Left and Right Imager (Intel® RealSense™ D400/D420) | Visible spectrum @ 98% transmission rate or higher at all viewing and transmitting angles | nm |
| IR Projector | 850nm ± 15 nm @ 98% transmission rate or higher at all viewing and transmitting angles | nm |

NOTES:

1. Higher transmissions @ 98% transmission rate or higher is recommended and not a requirement.
2. Intel RealSense Camera 400-Series provides control over laser power and sensor exposure. Minor loss of transmission due to cover material transmissivity might be compensated by increasing exposure when less light is able to reach the sensors and by increasing laser power for IR projector pattern projection loss.
3. Uncoated clear acrylic (plexiglass) plastic cover is an example for cover material
4. Anti-reflective coatings can help increase the transmission of cover material.

If different cover material is used in front of the cameras and the IR projector to maximize transmission based on component wavelengths, cover design considerations should ensure that the FOV of the cameras and FOP of the IR projector are not impacted.

7.11 Gaskets

Gaskets are recommended for providing optical isolation and dust protection. However, gaskets can impede FOV and place unwanted stress on the module or the individual sensor lens holders.

Gasket static force can deform the cosmetic baffle/lens holder resulting in poor image quality and permanent damage to the camera. Gaskets placed on the module stiffener can transfer chassis flex into the camera module causing loss of depth data. Gasket thickness has a large effect on the static force applied to the module surface. The thinner the seal, the greater the static force applied. Once the gasket is compressed, the static force will increase exponentially.

Figure 7-14. Illustration of Gasket Placement and Cover Material

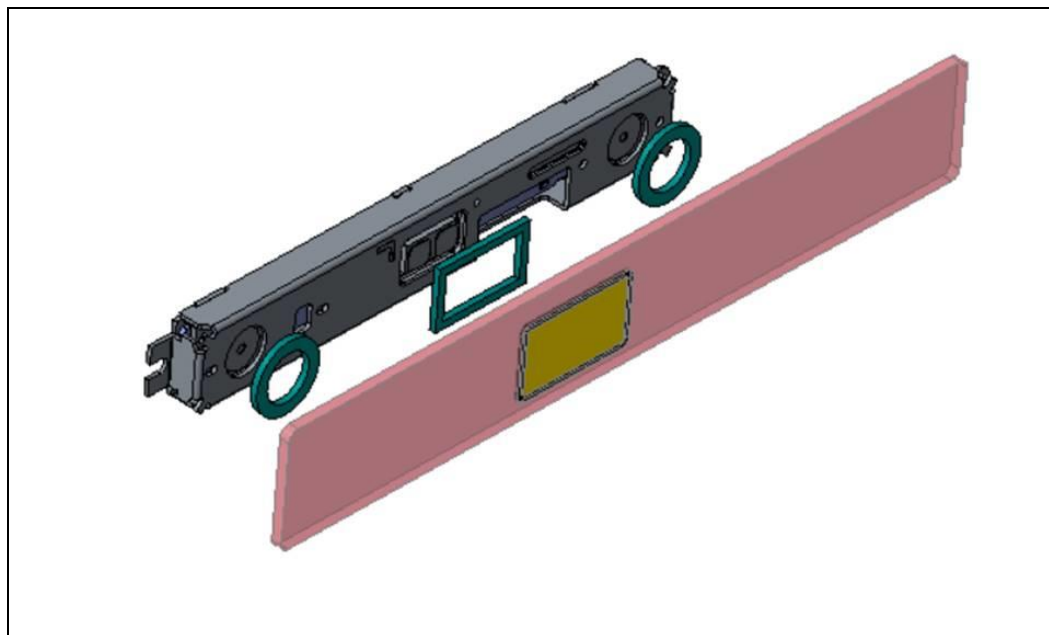

7.11.1 Optical Isolation

It is recommended to isolate the left/right imagers and IR projector from each other to prevent reflections off the cover material. Not properly isolating the cameras can result in leakage light as shown in [Figure 7-15. Example of Light Leakage Effects](#)

To prevent light leakage, it is recommended to use a gasket material in between the cover holes and the module. The gasket material needs to be compliant so that it does not transmit chassis flex forces to the module.

Figure 7-15. Example of Light Leakage Effects



7.11.2 Dust Protection

Dust particles can accumulate over the camera lenses which can be visually unappealing and degrade image quality.

7.12 Firmware Recovery

To support firmware recovery, a 3.3V controllable interrupt must be connected to the Vision Processor D4 DFU (Device Firmware Update) pin

The ability to recover the image system if the firmware becomes corrupted requires D4 reset and DFU pin driven high for 160ms. The DFU pin should remain high when D4 is out of reset for D4 to boot in DFU mode. The 160ms ensures that the DFU pin is held high through the reset sequence.

Figure 7-16. Firmware Recovery Sequence

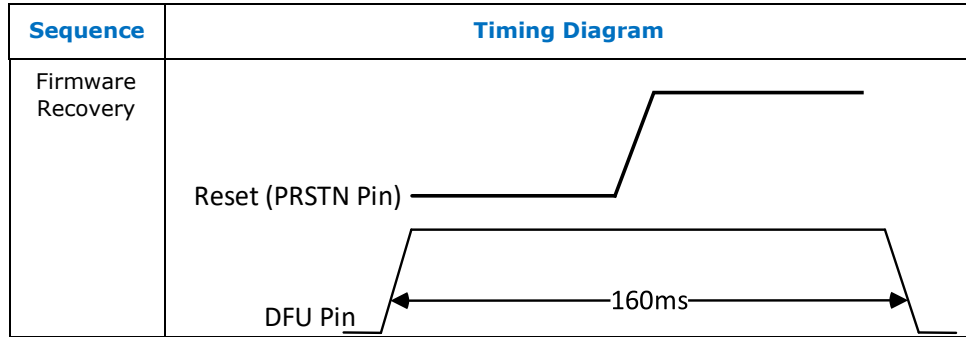

7.13 Calibration Support

It is required to have an accessible USB port to access the host system. The accessible USB port would allow to stream images reliably to an external PC to determine calibration parameters and to write back camera calibration parameters via the host system

The USB port should be able to be configured in a mode where the USB port can access the host. The access to USB port is required at manufacturing and not intended to be available on shipped product or to end user.

7.14 Multi-Camera Hardware Sync

Intel® RealSense™ D400 Series supports hardware sync signal for multi-camera configuration. For multiple cameras to be hardware synchronized as to capture at identical times and frame rates, pins 5 (SYNC) and pins 9 (Ground) on external sensor sync connector will need to be connected. The external sensor sync connector is on Vision Processor D4 board and is accessible on Depth Cameras.

Figure 7-17. External Sensor Sync Connector Location on D4 Vision Processor D4 Board

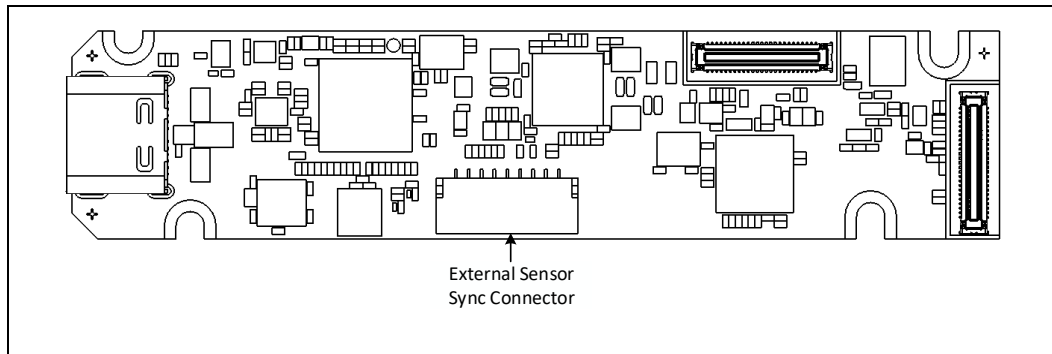
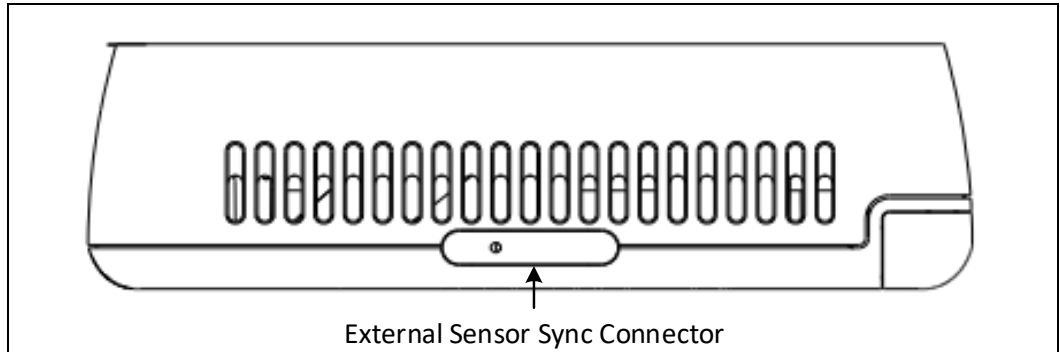



Figure 7-18. External Sensor Sync Connector Location on Depth Camera D435/D435i



For additional details on how to implement the multi-camera hardware sync feature, please refer to multi-camera white paper at <https://realsense.intel.com/intel-realsense-downloads/#whitepaper>.

7.15 Handling Conditions

Table 7-13. Electrostatic Discharge Caution

| | |
|--|---|
|  | <p>To provide a consistent ESD protection level during D4 system assembly and rework, it is recommended that the JEDEC JESD625-A requirements standard be incorporated into the ESD environment controls.</p> |
|--|---|

§ §

8 Platform Design Guidelines

The Platform Design Guidelines has been developed to ensure maximum flexibility for board designers while reducing the risk of board related issues. Design recommendations are based on Intel's simulations and are strongly recommended.

8.1 Vision Processor D4 on Motherboard

This Design Guidelines provides Vision Processor D4 on motherboard implementation recommendations for the Kaby Lake U/Y (7th Generation Intel® Core™ Processors) and Cherry Trail T4 (Intel® Atom™ Z8000 Processor Series) platforms with 8/10 layer Type 4 PCB.

Supported platform topologies are:

1. Vision Processor D4 with USB Host Interface
2. Vision Processor D4 with MIPI Host Interface
3. Vision Processor D4 on Board for USB Integrated Peripheral

Figure 8-1. Vision Processor D4 with USB Host Interface

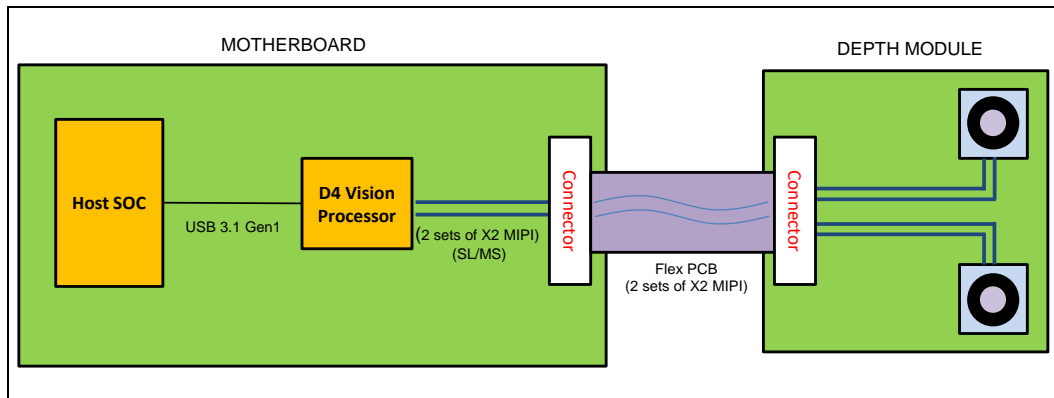

Figure 8-2. Vision Processor D4 with MIPI Host Interface

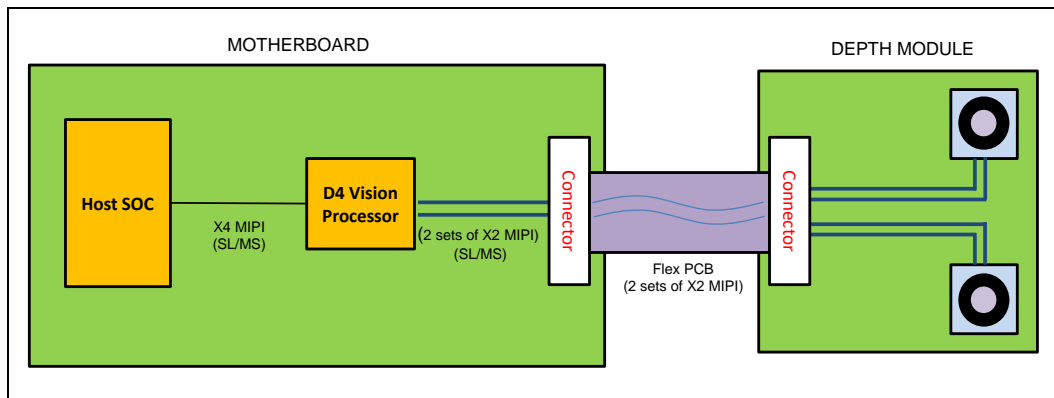
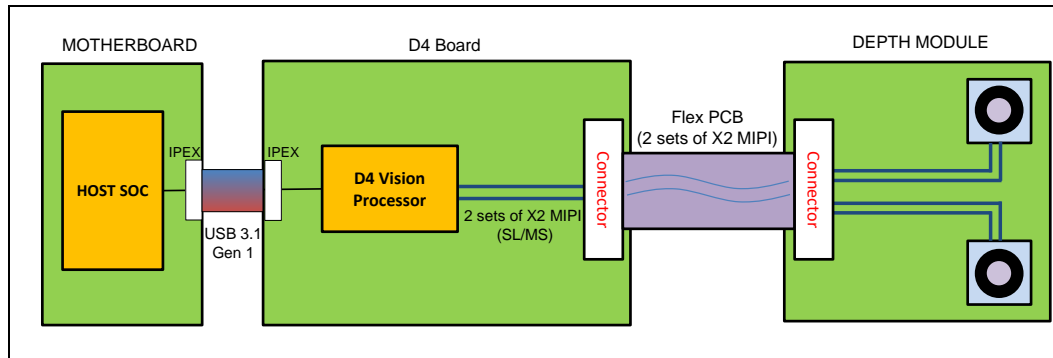

Figure 8-3. Vision Processor D4 on Board for USB Integrated Peripheral



8.2 Kaby Lake U and Kaby Lake Y platforms

8.2.1 Kaby Lake Platform Introduction

The Kaby Lake U platform consists of a Kaby Lake U processor plus a Kaby Lake Platform Controller Hub (PCH) in the same Multi Chip Package (MCP). Similarly the Kaby Lake Y platform consists of a Kaby Lake Y processor plus a Kaby Lake PCH in the same Multi Chip Package (MCP).

Note: For Kaby Lake U/Y platform design guidelines, refer Kaby Lake U and Y Platform Design Guide. (Doc# 561280)

8.2.2 Supported PCB Stack-Up and Routing Geometries

Refer to Kaby Lake U/Y Platform Design Guide for type 4 PCB stack up, Breakout/Breakin geometries, Main Route stripline/microstrip geometries and Via recommendations. It is strongly recommended to follow the given impedance criteria in the design guide for the given interface.

8.2.3 Vision Processor D4 on Motherboard with USB Host Interface

8.2.3.1 USB 3.1 Gen 1 Motherboard Routing

Figure 8-4. Host Processor - Vision Processor D4

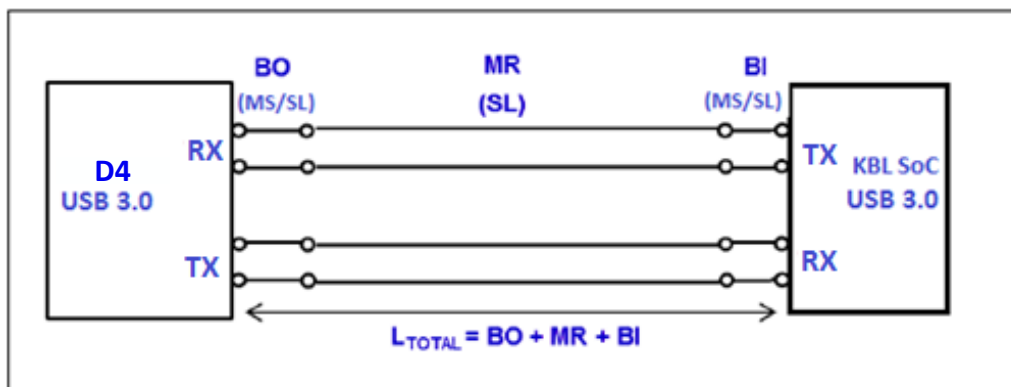

Table 8-1. Host Transmit – Vision Processor D4 Receive Routing Guidelines

| Parameter | Breakout (BO) | Main Route (MR) | Breakin (BI) | Total Allowed Length (L_BO + L_MR + L_BI) |
|---|---------------|-----------------|--------------|---|
| Maximum Segment Length (Inches) | 0.25 | 15-BO-BI | 0.25 | 15 |
| Maximum Allowed Channel Insertion loss (dB) | | | | <=15 dB @2.5MHz |

Table 8-2. Vision Processor D4 Transmit - Host Receive Routing Guidelines

| Parameter | Breakout (BO) | Main Route (MR) | Breakin (BI) | Total Allowed Length (L_BO + L_MR + L_BI) |
|---|---------------|-----------------|--------------|---|
| Maximum Segment Length (Inches) | 0.25 | 15-BO-BI | 0.25 | 15 |
| Maximum Allowed Channel Insertion loss (dB) | | | | <=15 dB @2.5MHz |

NOTES:

- Simulation results shows that overall 15 inch channel routing is good for USB 3.1 Gen 1 Vision Processor D4 to Host connection motherboard. This connection does not include any connector or cable.
- All routing is recommended to be 85 ohm impedance.

- Breakout/Breakin should be maximum length of 250 mil for 85 ohm routing, if there is any impedance variation due to narrow escape BGA breakout, the maximum routing length should be 150mil.
- Maximum number of via count:4 (including package microvia)
- It is strongly recommended that overall channel loss is within -15dB for satisfactory performance.

8.2.4 Vision Processor D4 on Motherboard with MIPI Host Interface

8.2.4.1 MIPI Motherboard Routing

Figure 8-5. Vision Processor D4 Transmit - Host Receive

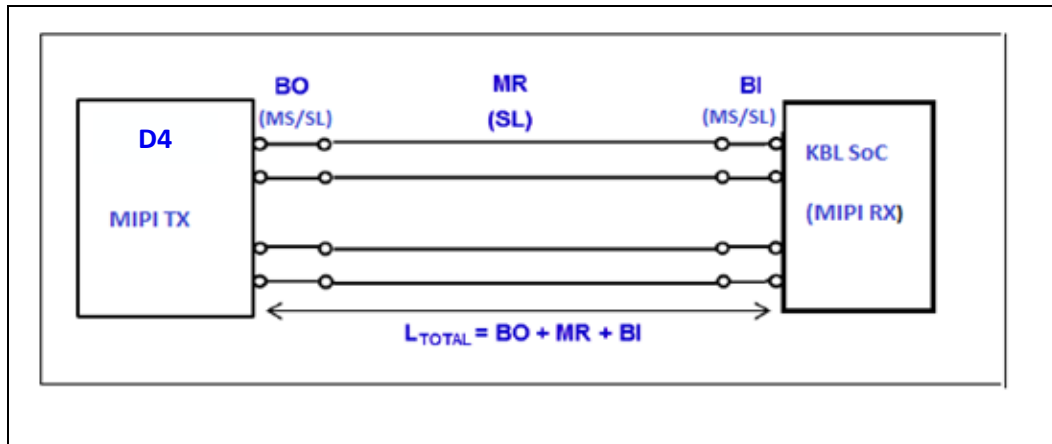

Table 8-3. Vision Processor D4 Transmit – Host Receive Routing Guidelines

| Parameter | Breakout (BO) | Main Route (MR) | Breakin (BI) | Total Allowed Length (L_BO + L_MR + L_BI) |
|---|---------------|-----------------|--------------|---|
| Maximum Segment Length (Inches) | 0.25 | 15-BO-BI | 0.25 | 15 |
| Maximum Allowed Channel Insertion loss (dB) | | | | <=5.5 dB @750MHz |

NOTES:

- Maximum via count = 4 vias including the first micro-via from package ball.
- Minimum stripline breakout pair-to-pair spacing of 2.36 mils is allowed near package ball out region with maximum length of 250 mils.
- Main route and Break-in nominal impedance is required to be consistent. Example: 85 ohm main route and 85 ohm break-in. Mixture of nominal impedance is not recommended.
- Length matching within a differential pair is +/- 5 mils maximum.

- The maximum allowed channel insertion loss budget dictates the total allowed length. The total insertion loss allowed for interconnect from the D4 package die bump to Kaby Lake SoC package die bump is about 5.5dB at 750 MHz. It should be noted that though only the insertion loss value at the fundamental frequency (750 MHz) is specified, the insertion loss curve up to about 1.5 GHz should be well behaved with no strong resonance or ripple.

8.2.4.2 MIPI Motherboard Routing (Stereo Depth Module Transmit to Vision Processor D4 Receive)

Figure 8-6. Stereo Depth Transmit - Vision Processor D4 Receive

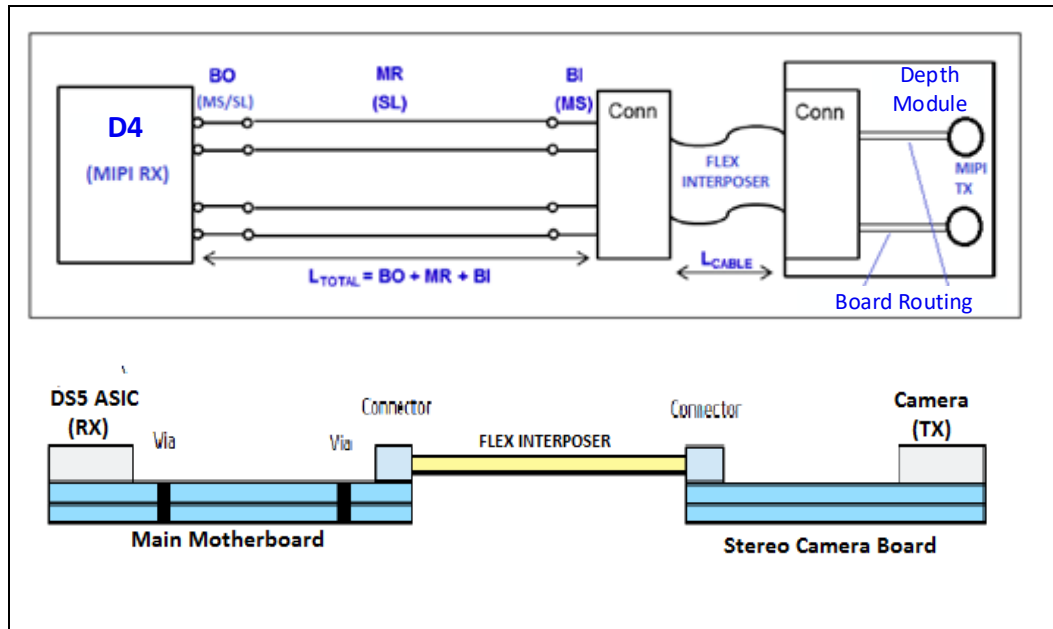

Table 8-4. Stereo Depth Module Transmit - Vision Processor D4 Receive Routing Guidelines

| Parameter | Breakout (BO) | Main Route (MR) | Breakin (BI) | Flex Interposer Length (L_Cable) | Camera Board Length (L_Camera) | Total Allowed Length (L_MB + L_Cable + L_Camera) |
|---|---------------|-----------------------------------|--------------|----------------------------------|--------------------------------|--|
| Maximum Segment Length (Inches) | 0.25 | 15 - L_Cable - L_Camera - BO - BI | 0.25 | 15-L_MB-L_camera | L_Camera (max ~2 inches) | 15 |
| Maximum Allowed Channel Insertion loss (dB) | | | | | | <=5.5 dB @750MHz |

NOTES:

- Stereo depth module MIPI routing length are assumed to be 2 inches (max)
- Maximum via count = 3 vias including the first micro-via from package ball.

- Minimum stripline breakout pair-to-pair spacing of 2.36 mils is allowed near package ball out region with maximum length of 250 mils.
- Main route and Break-in nominal impedance is required to be consistent. Example: 85 ohm main route and 85 ohm break-in. Mixture of nominal impedance is not recommended.
- Length matching within a differential pair is +/- 5 mils maximum.
- No length match requirements for signals routed to different camera modules.
- The maximum allowed channel insertion loss budget dictates the total allowed length. The total insertion loss allowed for interconnect from the package die bump to the connector on the camera module is about 5.5dB at 750 MHz as shown in the table. This recommendation allows the use of any cable type as long as the maximum allowed insertion loss is met. It should be noted that though only the insertion loss value at the fundamental frequency (750 MHz) is specified, the insertion loss curve up to about 1.5 GHz should be well behaved with no strong resonance or ripple.
- Flex Interposer recommendation: 85-100ohm impedance with maximum length of 4-6 inches. The recommended interposer should be Flex PCB based design.

Figure 8-7. Flex Interposer PCB Stack-Up

| | | | |
|---------|------------|--------|-----------|
| TOP | CONDUCTOR | COPPER | 0.984252 |
| | DIELECTRIC | FR-4 | 2.578740 |
| 02_SIG1 | CONDUCTOR | COPPER | 0.708661 |
| | DIELECTRIC | FR-4 | 1.968500 |
| 03_PWR1 | CONDUCTOR | COPPER | 0.708661 |
| | DIELECTRIC | FR-4 | 31.771700 |
| 04_GND1 | CONDUCTOR | COPPER | 0.708661 |
| | DIELECTRIC | FR-4 | 1.968500 |
| 05_SIG2 | CONDUCTOR | COPPER | 0.708661 |
| | DIELECTRIC | FR-4 | 2.578740 |
| BOTTOM | CONDUCTOR | COPPER | 0.984252 |

8.2.5 Vision Processor D4 Board for Integrated Peripheral (USB 3.1 Gen 1 Host to Vision Processor D4 Routing)

Figure 8-8. USB 3.1 Gen 1 Host to Vision Processor D4 Topology

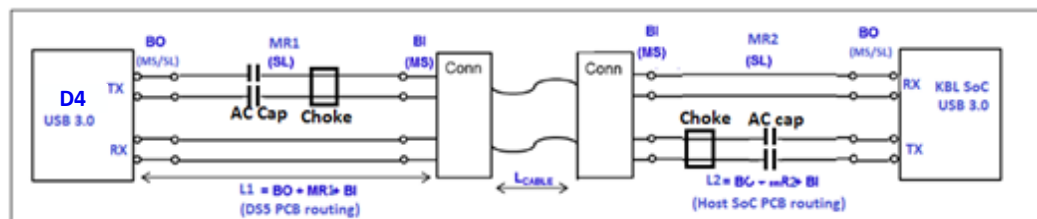

Table 8-5. USB 3.1 Gen 1 Host to Vision Processor D4 Routing Guidelines

| Parameter | Vision Processor D4 Board | | | USB 3.1 Gen 1 Cable | Host Motherboard | | |
|---|---|-----------------|--------------|------------------------|------------------|-----------------|--------------|
| | Breakout (BO) | Main Route (MR) | Breakin (BI) | Cable Length (L_Cable) | Breakout (BO) | Main Route (MR) | Breakin (BI) |
| Maximum Segment Length (Inches) | 0.25 | 2 | 0.25 | 15 (max) | 0.25 | 5 | 0.25 |
| Maximum Allowed Channel Insertion loss (dB) | <= 15 dB @ 2.5GHz Max recommended USB 3.1 Gen 1 cable loss <= 7.5 dB @2.5GHz | | | | | | |

NOTES:

- The maximum allowable motherboard routing of USB 3.1 Gen 1 signals on Host PCB should be 5-6inch and routing on Vision Processor D4 Board should be 2-3inch.
- It is recommended that an 85 ohm common mode choke (CMC) be designed in line with both the USB 3.1 Gen 1 signals. The CMC should be placed as close to the connector as possible.
- It is required that a 0.1µF AC coupling capacitor is designed in series with both the USB 3.1 Gen 1 signals.
- The USB 3.1 Gen 1 cable assembly should have a differential impedance of 85 Ohms with a tolerance of ± 10%.
- The max cable length should not exceed 15 inch with target loss of 7.5dB@2.5GHz
- Overall channel loss including cable should not exceed 15dB @2.5GHz

8.2.6 USB2.0 Design Guidelines (USB2 Host to Vision Processor D4 Routing)

Figure 8-9. USB2.0 Host to Vision Processor D4

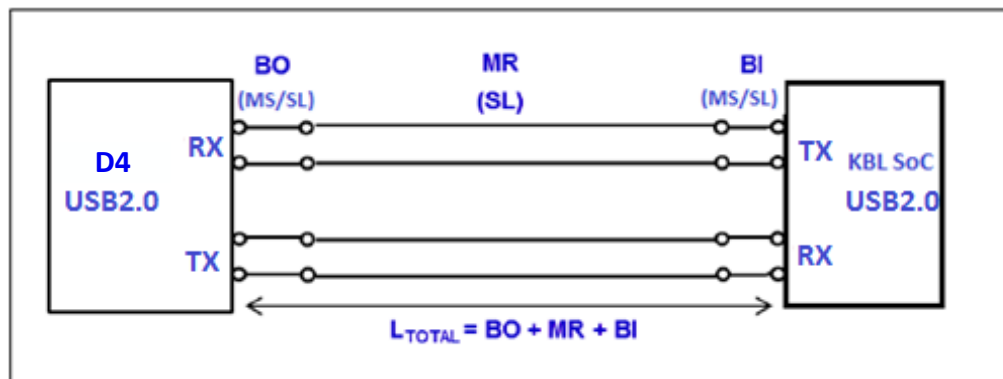

| Parameter | Breakout (BO) | Main Route (MR) | Breakin (BI) | Total Allowed Length (L_BO + L_MR + L_BI) |
|---|---------------|-----------------|--------------|---|
| Maximum Segment Length (Inches) | 0.25 | 15-BO-BI | 0.25 | 15 |
| Maximum Allowed Channel Insertion loss (dB) | | | | |

NOTES:

- Simulation results shows that overall 15 inch channel routing is good for USB2.0 D4 to Host topology on motherboard. This topology does not include any connector or cable.
- All routing is recommended to be 85 ohm
- Breakout/breakin should be max of 250mil for 85ohm routing, if there is any impedance variation due to narrow escape BGA breakout, the max routing should be 150mil.
- Maximum number of via count:4 (including package microvia)
- It is strongly recommended that overall channel loss to be within -15dB for satisfactory performance

8.3 Cherry Trail T4 Platform

8.3.1 Cherry Trail T4 Platform Introduction

The Cherry Trail T4 is the Intel Architecture (IA) SoC that integrates the Intel® processor core, Graphics, Memory Controller, and I/O interfaces into a single system-on-chip solution.

Note: For Cherry Trail T4 platform design guidelines, refer Cherry Trail T4 Platform Design Guide. (Doc# 537901)

Note: Cherry Trail platform supports 2 SoC skus, T3 and T4. The Vision Processor D4 platform design guidelines discussed in this chapter are only applicable to T4 based Cherry Trail platform. For information on Cherry Trail T4 SoC, refer to Intel® Atom™ Z8000 Processor Series - External Design Specification (EDS) (Doc# 539071)

8.3.2 Vision Processor D4 Platform Design Guidelines

The Vision Processor D4 platform design guidelines on Cherry Trail T4 platform would follow the same guidelines specified for Kaby Lake U and Y platforms.

8.3.2.1 Supported PCB Stack-Up and Routing Geometries

Refer to Cherry Trail T4 Platform Design Guide for Type 4 PCB stack up, Breakout/Breakin routing geometry, Main Route stripline/microstrip geometry and Via recommendations. It is strongly recommend to follow the given impedance criteria in the design guide for the given interface.



9 Regulatory Compliance

9.1 System Laser Compliance

The Intel® RealSense™ D400 series certification is transferable to the system and no system recertification is required. However, the following statements and labels must be included in the user manual of the end product

9.1.1 Certification Statement

This product is classified as a Class 1 Laser Product under the EN/IEC 60825-1, Edition 3 (2014) internationally and IEC60825-1, Edition 2 (2007) in the US.

This product complies with US FDA performance standards under 21 CFR 1040.10 for laser products except for deviations pursuant to Laser Notice No. 50 dated June 24, 2007.

9.1.2 Explanatory Label

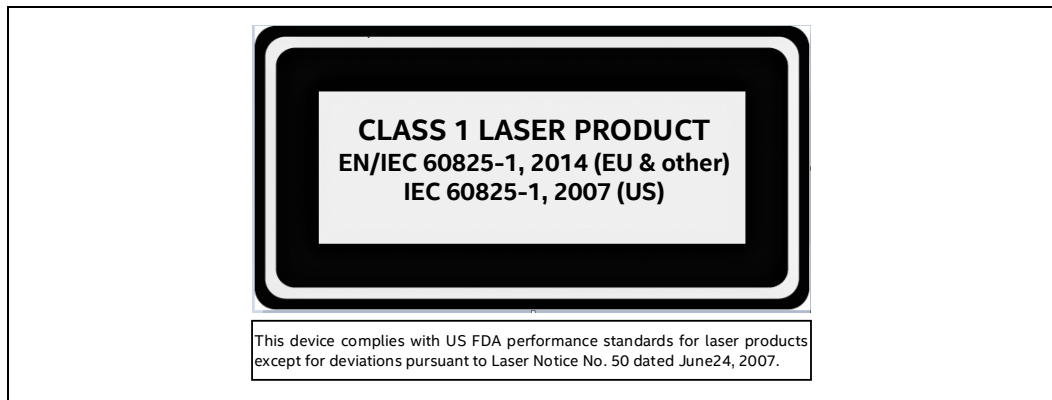

9.1.3 Cautionary Statements

 System integrators should refer to their respective regulatory and compliance owner to finalize regulatory requirements for a specific geography.

 **Caution** - Use of controls or adjustments or performance of procedures other than those specified herein may result in hazardous radiation exposure.



Do not power on the product if any external damage was observed. There are no service/maintenance, modification, or disassembly procedures for the stereo module and infrared projector. The system integrator must either notify Intel or return modules before any failure analysis is performed.

Do not attempt to open any portion of this laser product. Invisible laser radiation when opened. Avoid direct exposure to beam. There are no user serviceable parts with this laser product.

Modification or service of the stereo module, specifically the infrared projector, may cause the emissions to exceed Class 1.

No magnifying optical elements, such as eye loupes and magnifiers, are allowed.

Do not try to update camera firmware that is not officially released for specific camera module SKU and revision.

9.1.4 Manufacturer’s Information

Manufactured by Intel Corporation
 2200 Mission College Blvd., Santa Clara, CA 95054 USA

9.1.5 US FDA Accession Number

Table 9-1. U.S. FDA Accession Number

| Component | U.S. FDA accession numbers |
|--|----------------------------|
| Intel® RealSense™ Depth Module D410/D415 | 1420260-006 |
| Intel® RealSense™ Depth Module D430 | 1420260-007 |

This accession number should be entered into Box B.1 of the Food and Drug Administration (FDA) 2877 Declaration for Imported Electronic Products Subject to Radiation Control Standards.

9.1.6 NRTL Statement

For the US and Canada market, this product has been tested and certified by UL and Nemko, and found to be compliant with all applicable requirements of the specifications below.

UL 60950-1 2nd Edition, CAN/CSA C22.2 No. 60950-1-07, Information Technology Equipment – Safety – Part 1: General Requirements

Both UL and Nemko are Nationally Recognized Testing Laboratories (NRTLs), recognized by US Occupational Safety and Health Administration (OSHA) as qualified to perform safety testing and certifications covered within its scope of recognition.

Figure 9-1. NRTL Certifications

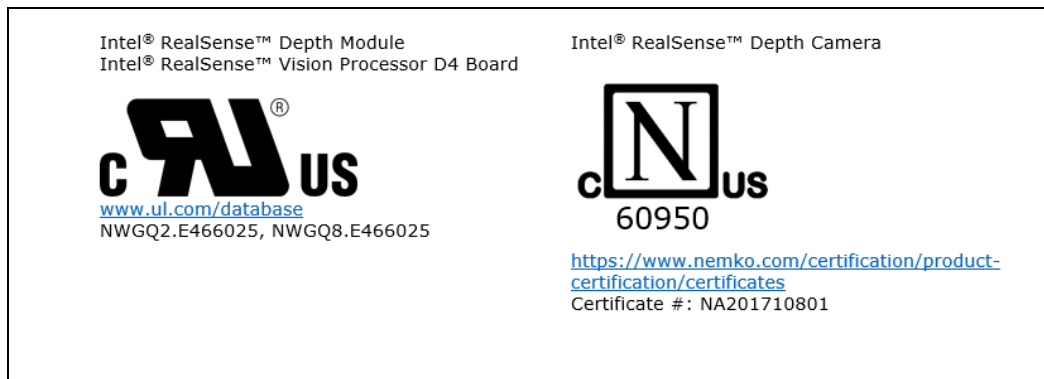

9.2 Ecology Compliance

9.2.1 China RoHS Declaration

China RoHS Declaration

产品中有毒有害物质的名称及含量

Hazardous Substances Table

| 部件名称 Component Name | 有毒有害物质或元素 Hazardous Substance | | | | | |
|-------------------------------------|-------------------------------|---------|---------|----------------|-------------|---------------|
| | 铅 Pb | 汞 Hg | 镉 Cd | 六价铬 Cr (VI) | 多溴联苯 PBB | 多溴二苯醚 PBDE |
| 相机 Camera | X | ○ | ○ | ○ | ○ | ○ |
| 印刷电路板组件 Printed Board Assemblies | X | ○ | ○ | ○ | ○ | ○ |

○：表示该有毒有害物质在该部件所有均质材料中的含量均在GB/T 26572标准规定的限量要求以下。
 ○：Indicates that this hazardous substance contained in all homogeneous materials of such component is within the limits specified in GB/T 26572.
 ×：表示该有毒有害物质至少在该部件的某一均质材料中的含量超出GB/T 26572标准规定的限量要求。

×: Indicates that the content of such hazardous substance in at least a homogeneous material of such component exceeds the limits specified in GB/T 26572.

对销售之日的所售产品,本表显示我公司供应链的电子产品信息产品可能包含这些物质。注意:在所售产品中可能会也可能不会含有所有所列的部件。

This table shows where these substances may be found in the supply chain of our electronic information products, as of the date of sale of the enclosed product. Note that some of the component types listed above may or may not be a part of the enclosed product.

除非另外特别的标注,此标志为针对所涉及产品的环保使用期限标志。某些可更换的零部件可能会有一个不同的环保使用期限(例如,电池单元模块)。

此环保使用期限只适用于产品在产品手册中所规定的条件下工作。



The Environment-Friendly Use Period (EFUP) for all enclosed products and their parts are per the symbol shown here, unless otherwise marked. Certain field-replaceable parts may have a different EFUP (for example, battery modules) number. The Environment-Friendly Use Period is valid only when the product is operated under the conditions defined in the product manual.

9.2.2 Waste Electrical and Electronic Equipment (WEEE)



"In the EU, this symbol means that this product must not be disposed of with household waste. It is your responsibility to bring it to a designated collection point for the recycling of waste electrical and electronic equipment. For more information, contact the local waste collection center or your point of purchase of this product."



10 Mechanical Drawings

Figure 10-1. Intel® RealSense™ Depth Module D400

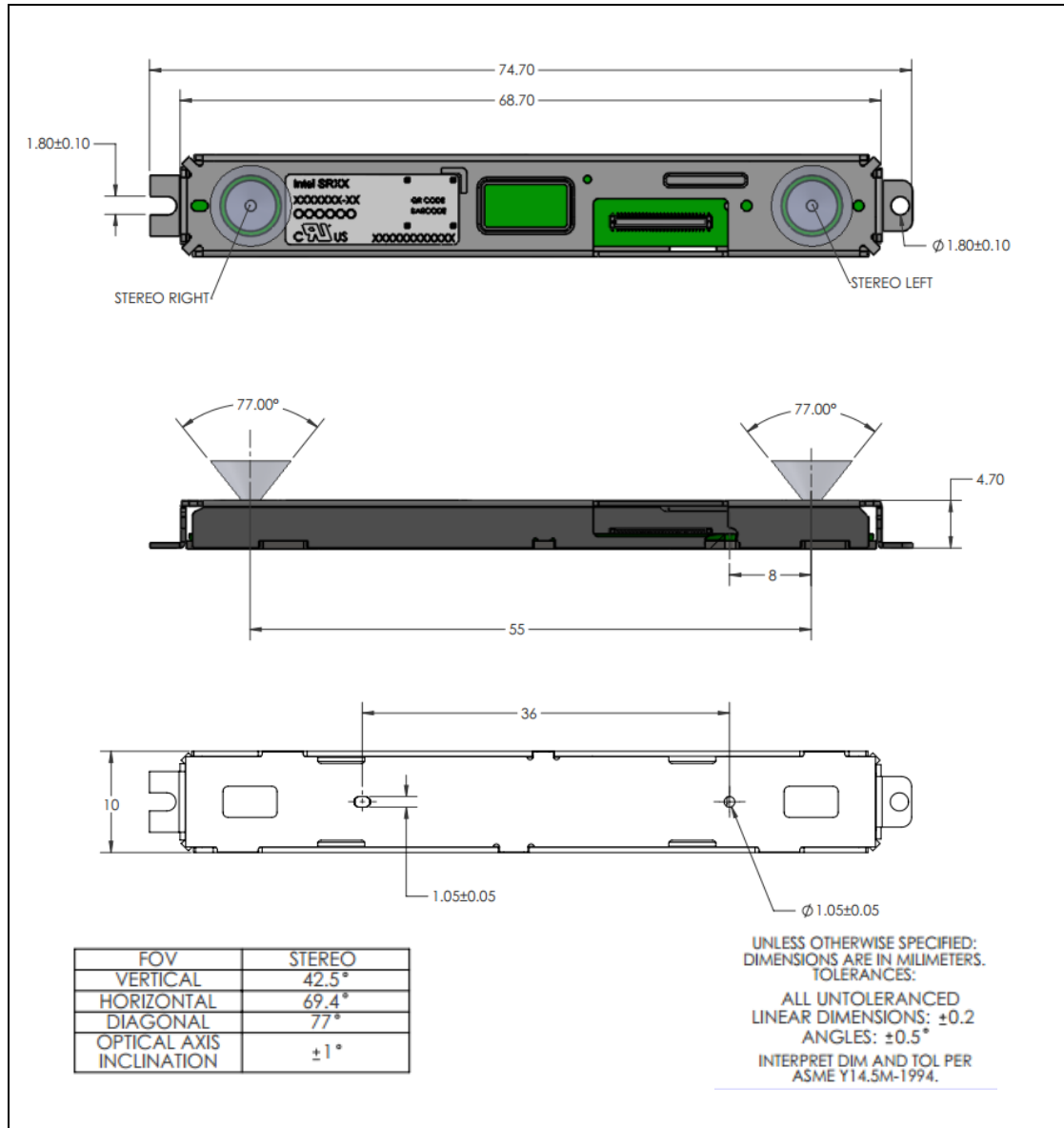

Figure 10-2. Intel® RealSense™ Depth Module D410

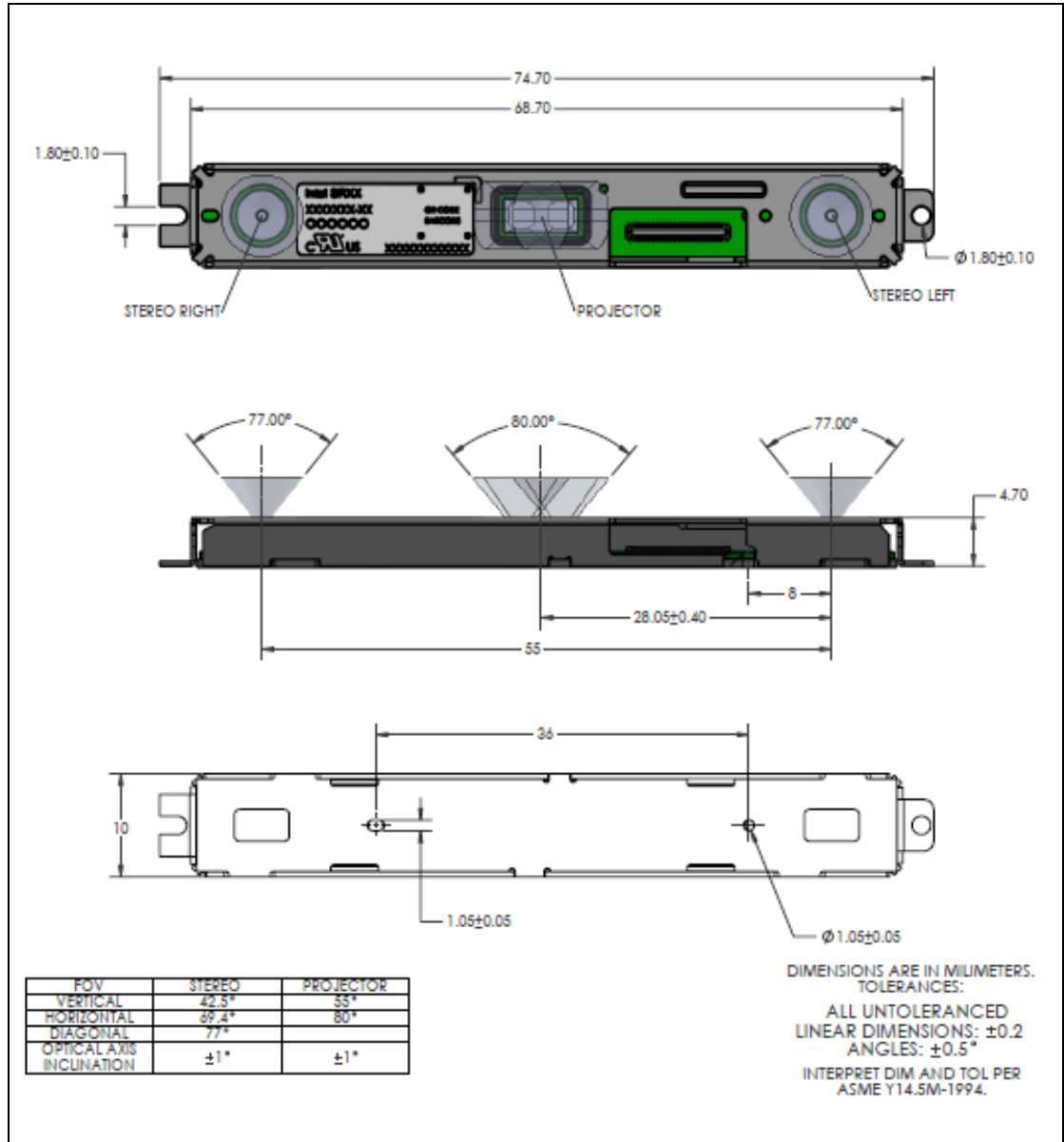

Figure 10-3. Intel® RealSense™ Depth Module D415

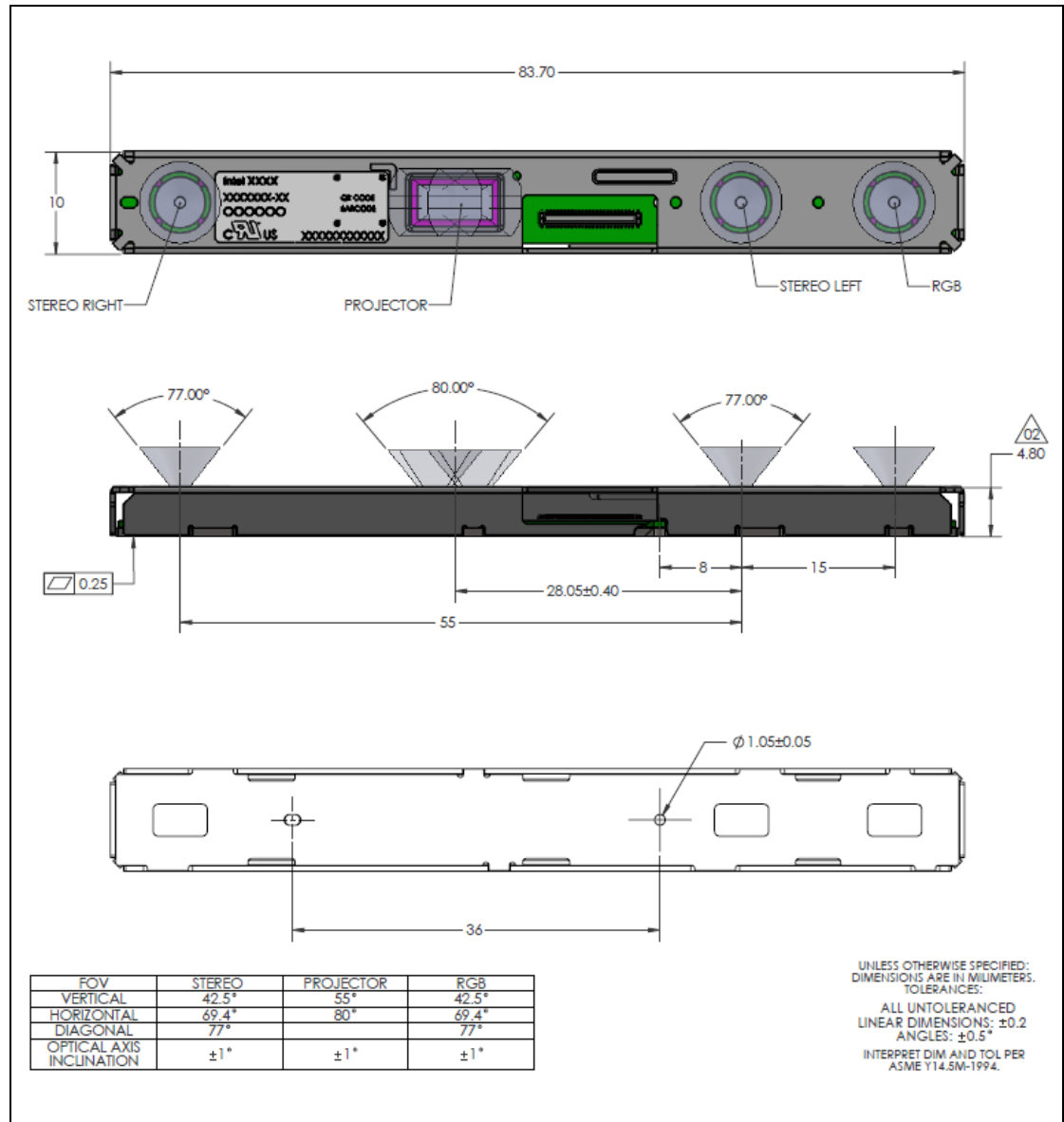

Figure 10-4. Intel® RealSense™ Depth Module D420

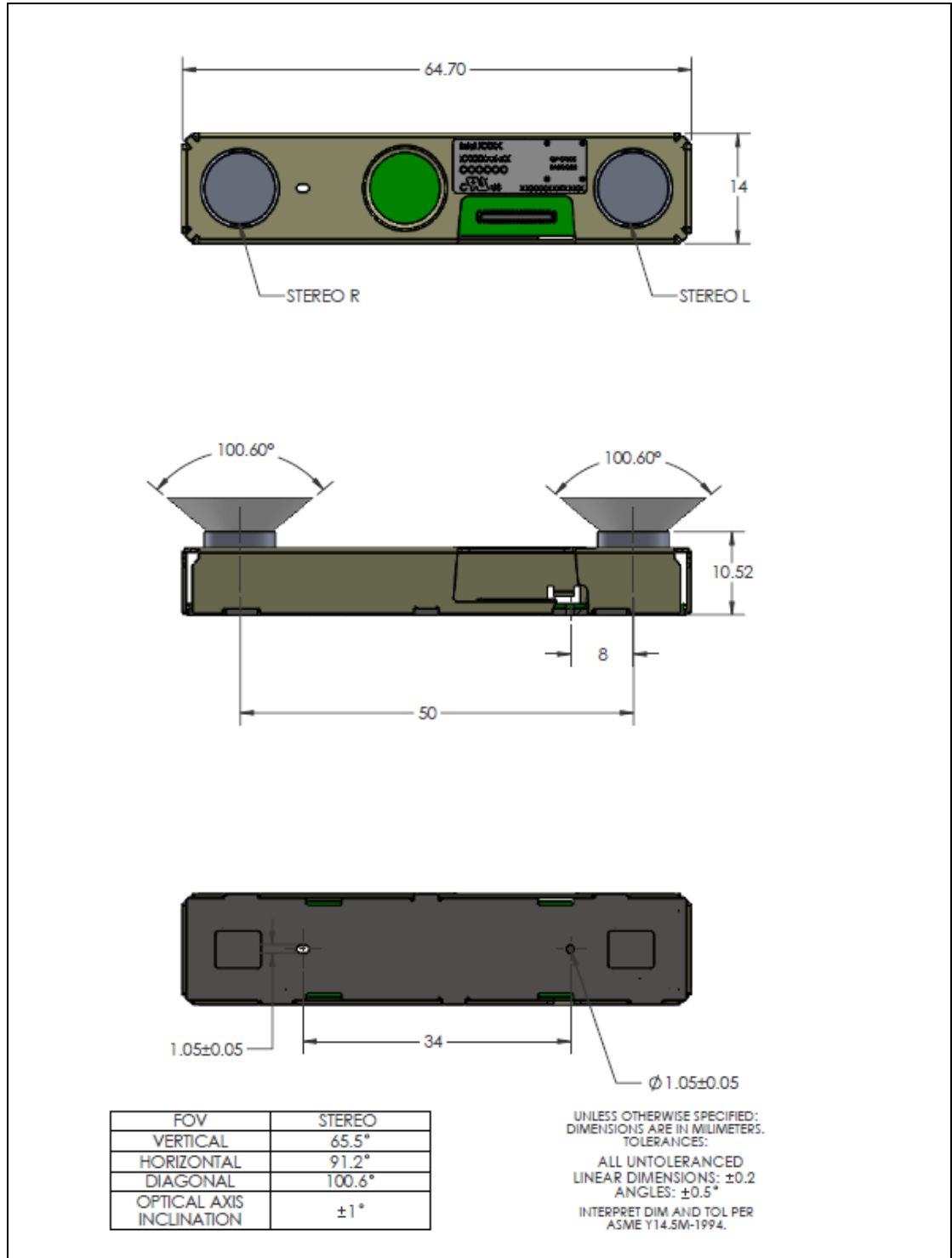

Figure 10-5. Intel® RealSense™ Depth Module D430

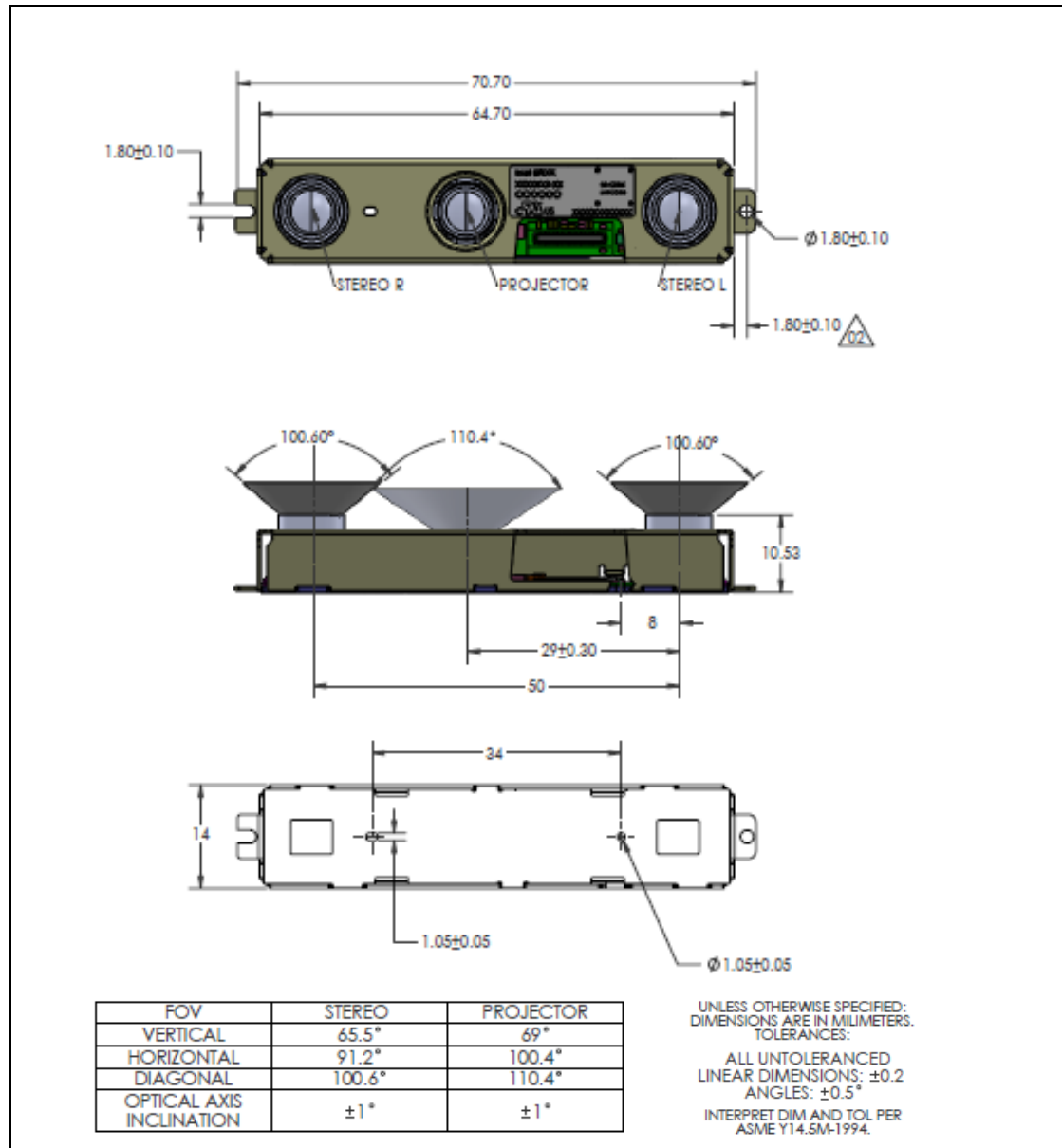

Figure 10-6. Vision Processor D4 Board USB Type-C (Intel® RealSense™ Vision Processor D4 Board)

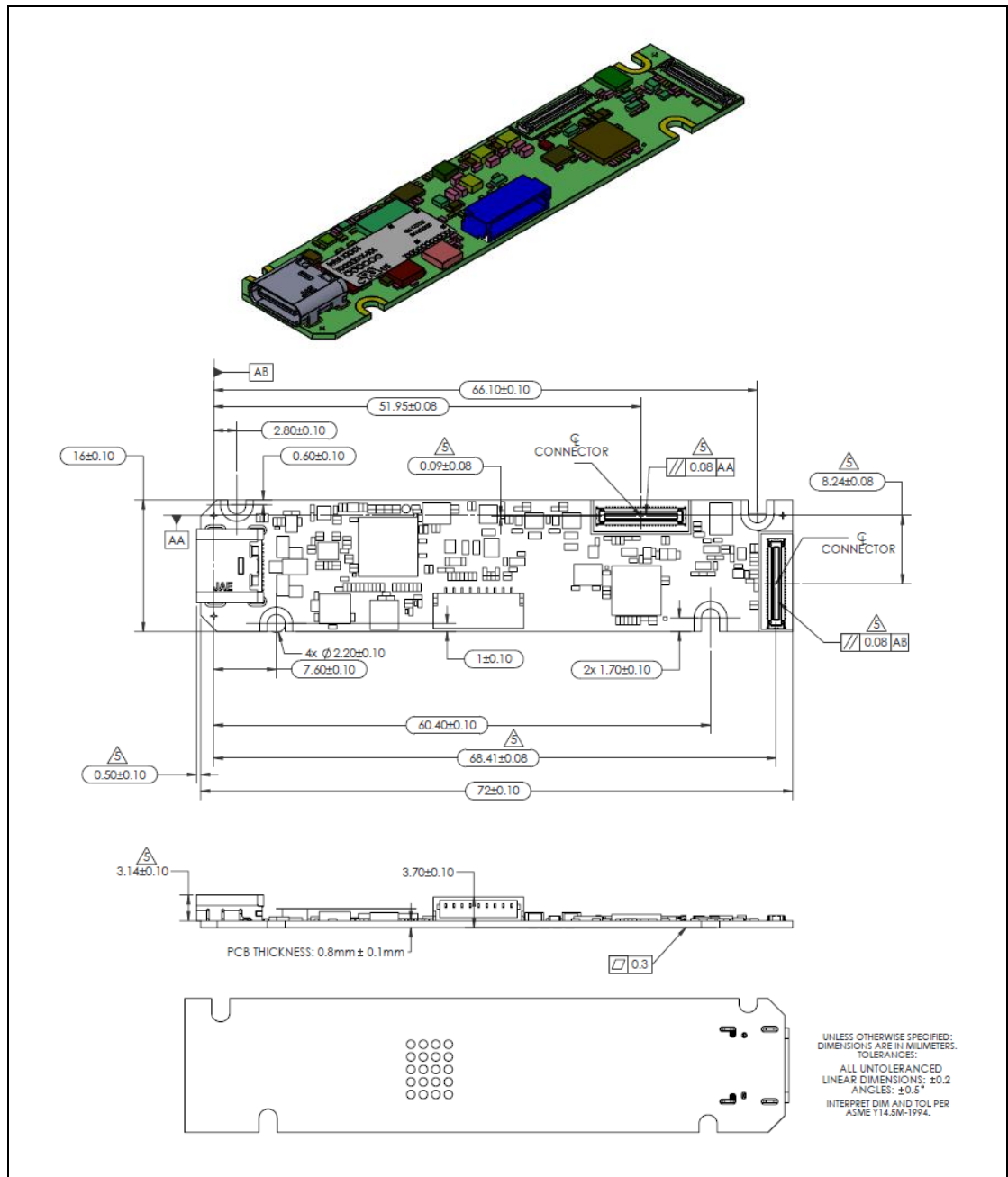
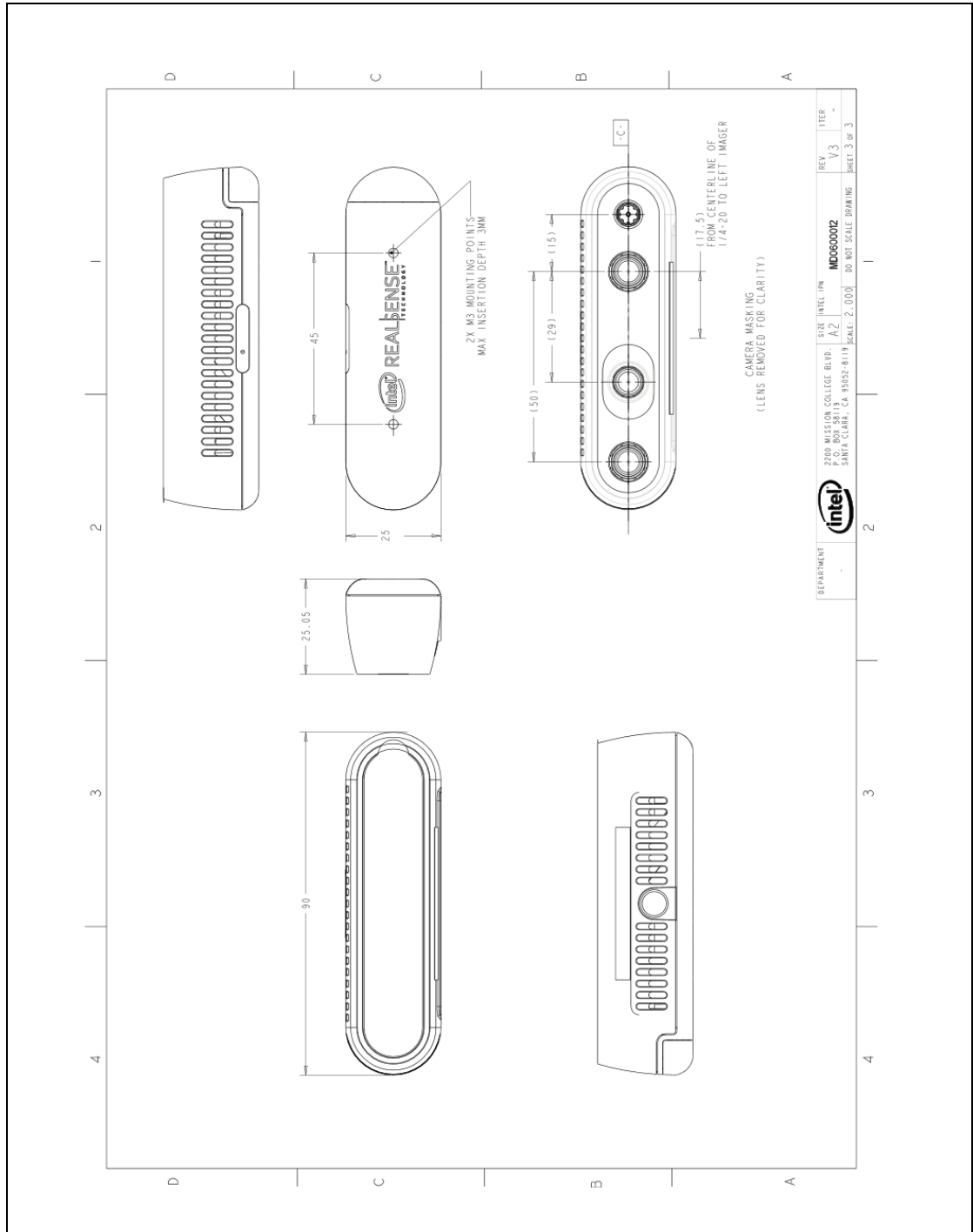

Figure 10-8. Intel® RealSense™ Depth Camera D435/D435i



11 Connector Drawings

Figure 11-1. Receptacle Mechanical Drawing (50 Pin Depth Module Receptacle)

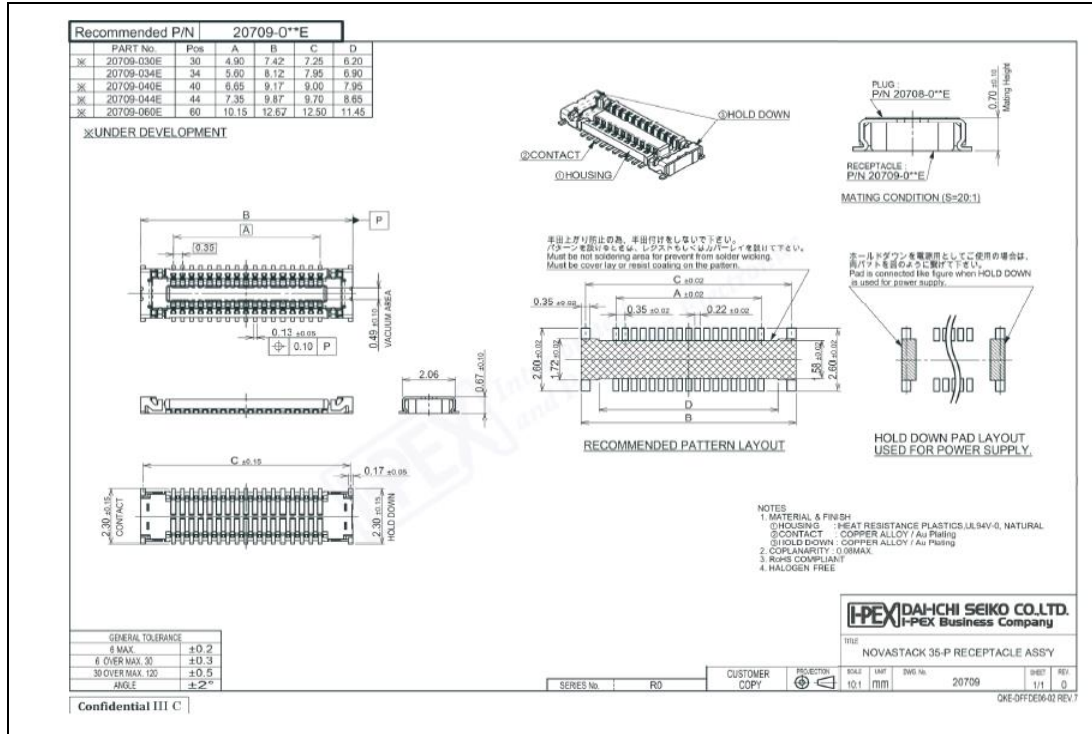
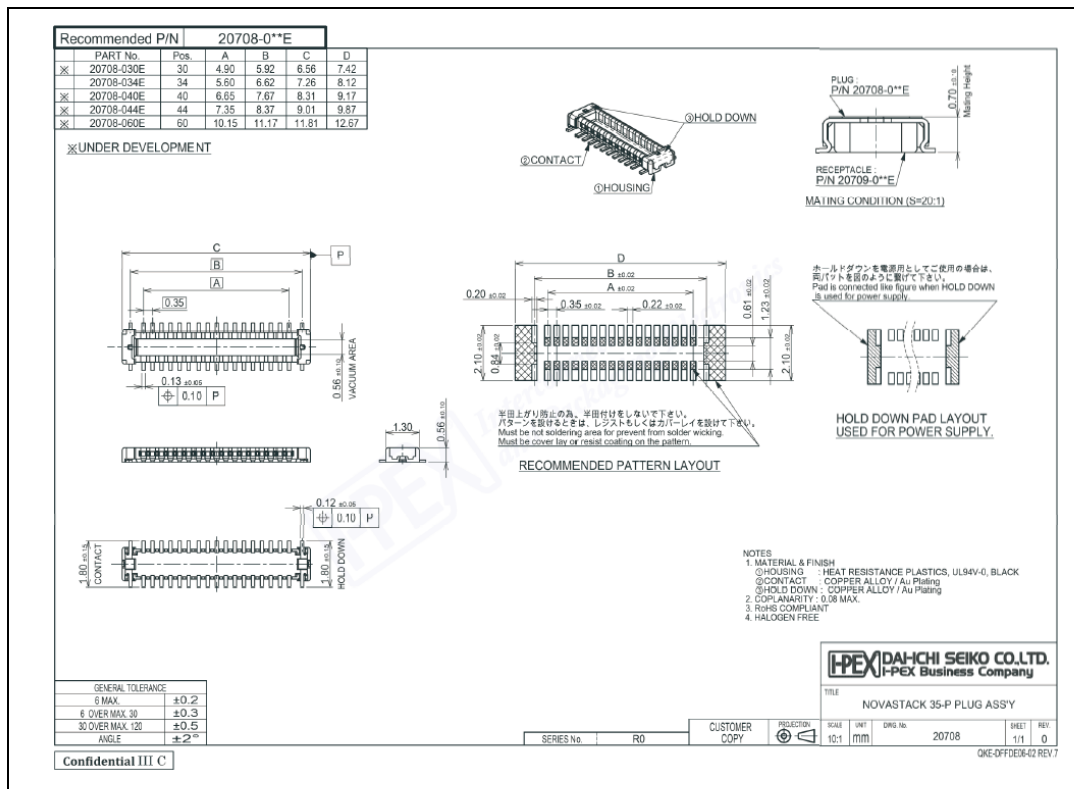

Figure 11-2. Plug Mechanical Drawing (50 pin Depth Module Plug)



§ §

12 Appendix A – Vision Processor D4 on Motherboard Schematic Checklist

The following checklist should be compared to the D4 on motherboard design.

Table 12-1. Vision Processor D4 on Motherboard Schematic Checklist

Note: Vision Processor D4 Ball Out and Signal Listing lists additional interfaces and signal pins that are not supported in current D4 camera system. These pins are called out as **RESERVED**

Stuff - Component is populated

No Stuff – Component is not populated

| Signal Name | Pad | Connection | ✓ |
|---|-----|---|---|
| HOST MIPI | | | |
| H_DATAP0 | B04 | No Connect | |
| H_DATAN0 | A05 | No Connect | |
| H_DATAP1 | B05 | No Connect | |
| H_DATAN1 | A06 | No Connect | |
| H_DATAP2 | B07 | No Connect | |
| H_DATAN2 | A08 | No Connect | |
| H_DATAP3 | B08 | No Connect | |
| H_DATAN3 | A09 | No Connect | |
| H_CLKP | B06 | No Connect | |
| H_CLKN | A07 | No Connect | |
| H_SDA | B03 | No Connect | |
| H_SCL | A04 | No Connect | |
| H_REXT | C05 | 6.04K 1% resistor pull down to GND. (This resistor should be placed as close to ASIC as possible) | |
| IMAGER A MIPI (Stereo Depth Left Imager Interface) | | | |
| A_DATAP0 | P03 | Routed to Stereo Depth Receptacle Pin 16 | |
| A_DATAN0 | R02 | Routed to Stereo Depth Receptacle Pin 18 | |
| A_DATAP1 | P05 | Routed to Stereo Depth Receptacle Pin 28 | |

| Signal Name | Pad | Connection | ✓ |
|--|-----|---|---|
| A_DATAN1 | R04 | Routed to Stereo Depth Receptacle Pin 30 | |
| A_CLKP | P04 | Routed to Stereo Depth Receptacle Pin 22 | |
| A_CKLN | R03 | Routed to Stereo Depth Receptacle Pin 24 | |
| A_SDA | N01 | Routed to Stereo Depth Receptacle Pin 41 with 2.2K pull up to 1.8V | |
| A_SCL | N02 | Routed to Stereo Depth Receptacle Pin 39 with 2.2K pull up to 1.8V | |
| A_RCLK | P02 | Routed to Stereo Depth Receptacle Pin 27 | |
| A_PDOWN | N03 | No Connect | |
| A_VSYNC | M01 | Routed to Stereo Depth Receptacle Pin 23 | |
| A_RESETN | P01 | Routed to Stereo Depth Receptacle Pin 31 | |
| A_REXT | N04 | 6.04K 1% resistor pull down to GND. (This resistor should be placed as close to ASIC as possible) | |
| IMAGER B MIPI (Reserved) | | | |
| B_DATAP0 | B11 | No Connect | |
| B_DATAN0 | A12 | No Connect | |
| B_DATAP1 | B09 | No Connect | |
| B_DATAN1 | A10 | No Connect | |
| B_CLKP | B10 | No Connect | |
| B_CKLN | A11 | No Connect | |
| B_SDA | C12 | No Connect | |
| B_SCL | B12 | No Connect | |
| B_RCLK | C07 | No Connect | |
| B_PDOWN | C09 | No Connect | |
| B_VSYNC | C08 | No Connect | |
| B_RESETN | C10 | No Connect | |
| B_REXT | C11 | 6.04K 1% resistor pull down to GND. (This resistor should be placed as close to ASIC as possible) | |
| IMAGER M MIPI (Stereo Depth Right Imager) | | | |
| M_DATAP0 | P08 | Routed to Stereo Depth Receptacle Pin 34 | |

| Signal Name | Pad | Connection | ✓ |
|----------------------------------|-----|---|---|
| M_DATAN0 | R07 | Routed to Stereo Depth Receptacle Pin 36 | |
| M_DATAP1 | P10 | Routed to Stereo Depth Receptacle Pin 46 | |
| M_DATAN1 | R09 | Routed to Stereo Depth Connector Pin 48 | |
| M_CLKP | P09 | Routed to Stereo Depth Receptacle Pin 40 | |
| M_CKLN | R08 | Routed to Stereo Depth Receptacle Pin 42 | |
| M_SDA | P06 | Routed to External Sensor Sync Connector Pin 6 through 2.2K pull up to 1.8V | |
| M_SCL | R05 | Routed to External Sensor Sync Connector Pin 7 through 2.2K pull up to 1.8V | |
| M_RCLK | R06 | Routed to Stereo Depth Receptacle Pin 37 | |
| M_PDOWN | P07 | No Connect | |
| M_VSYNC | N06 | No Connect | |
| M_RESETN | N07 | No Connect | |
| M_REXT | M06 | 6.04K 1% resistor pull down to GND. (This resistor should be placed as close to ASIC as possible) | |
| IMAGER Y MIPI (Color ISP) | | | |
| Y_DATAP0 | C14 | Routed to Color ISP (Intel®Vision Processor D4 Board) or No Connect | |
| Y_DATAN0 | B15 | Routed to Color ISP (Intel®Vision Processor D4 Board) or No Connect | |
| Y_DATAP1 | B13 | Routed to Color ISP (Intel®Vision Processor D4 Board) or No Connect | |
| Y_DATAN1 | A13 | Routed to Color ISP (Intel®Vision Processor D4 Board) or No Connect | |
| Y_CLKP | B14 | Routed to Color ISP (Intel®Vision Processor D4 Board) or No Connect | |
| Y_CKLN | A14 | Routed to Color ISP (Intel®Vision Processor D4 Board) or No Connect | |
| Y_SDA | E14 | Routed to Color ISP (Intel®Vision Processor D4 Board) or No Connect | |
| Y_SCL | D15 | Routed to Color ISP (Intel®Vision Processor D4 Board) or No Connect | |
| Y_RCLK | D14 | Routed to Color ISP (Intel®Vision Processor D4 Board) or No Connect | |
| Y_PDOWN | E13 | No Connect | |

| Signal Name | Pad | Connection | ✓ |
|----------------------------------|-----|---|---|
| Y_VSYNC | F13 | Routed as RGB_FSYNC to Stereo Depth Receptacle Pin 7 through 0 ohm stuff resistor. Alternately also as routed as RGB_STROBE to Stereo Depth Receptacle Pin 9 through 0 ohm no stuff resistor. | |
| Y_RESETN | F14 | Routed to Color ISP (Intel®Vision Processor D4 Board) or No Connect | |
| Y_REXT | C15 | 6.04K 1% resistor pull down to GND. (This resistor should be placed as close to ASIC as possible) | |
| IMAGER Z MIPI (Reserved) | | | |
| Z_DATAPO | P13 | No Connect | |
| Z_DATAN0 | R12 | No Connect | |
| Z_DATAP1 | P11 | No Connect | |
| Z_DATAN1 | R10 | No Connect | |
| Z_CLKP | P12 | No Connect | |
| Z_CKLN | R11 | No Connect | |
| Z_SDA | N13 | No Connect | |
| Z_SCL | N12 | No Connect | |
| Z_RCLK | R13 | No Connect | |
| Z_PDOWN | N11 | No Connect | |
| Z_VSYNC | R14 | Depth VSYNC - Routed to External Sensor Sync Connector Pin 5 | |
| Z_RESETN | P14 | No Connect | |
| Z_REXT | N10 | 6.04K 1% resistor pull down to GND. (This resistor should be placed as close to ASIC as possible) | |
| SPI (SERIAL FLASH MEMORY) | | | |
| SPI_DI | N14 | Routed to 16Mbit SERIAL FLASH MEMORY (IS25WP016 pin 5 or equivalent) | |
| SPI_DO | N15 | Routed to 16Mbit SERIAL FLASH MEMORY (IS25WP016 pin 2 or equivalent) | |
| SPI_CLK | M14 | Routed to 16Mbit SERIAL FLASH MEMORY (IS25WP016 pin 6 or equivalent) | |
| SPI_CS | M13 | Routed to 16Mbit SERIAL FLASH MEMORY (IS25WP016 pin 1 or equivalent) | |
| SPI_WP | M15 | Routed to 16Mbit SERIAL FLASH MEMORY (IS25WP016 pin 3 or equivalent) | |
| GPIO | | | |

| Signal Name | Pad | Connection | ✓ |
|-------------|-----|---|---|
| GPIO[0] | E15 | No Connect if not used. | |
| GPIO[1] | F15 | No Connect if not used. | |
| GPIO[2] | G14 | LASER_PWM - Routed to Stereo Depth Receptacle pin 43 with 0 ohm no stuff resistor. Refer to LASER_PWM platform implementation schematic in Figure 10-1. Laser PWM0 is routed to Stereo Depth Receptacle Pin 43 through 0 ohm stuff resistor. Laser PWM1 is routed to Stereo Depth Receptacle Pin 47 | |
| GPIO[3] | H14 | GVSYNCO - Routed to External Sensor Sync Connector Pin 1 | |
| GPIO[4] | G13 | GVSYNCO1 - Routed to External Sensor Sync Connector pin 2 through 0 ohm stuff resistor with optional LASER_PWRDN through 0 ohm no stuff resistor or No Connect if not used. | |
| GPIO[5] | G15 | GVSYNCO2 - Routed to External Sensor Sync Connector pin 3 through 0 ohm stuff resistor with optional FLAGB through 0 ohm no stuff resistor or No Connect if not used. | |
| GPIO[6] | H15 | GVSYNCO3 - Routed to External Sensor Sync Connector pin 4 through 0 ohm stuff resistor with optional LASER_PWM through 0 ohm no stuff resistor or No Connect if not used. | |
| GPIO[7] | H13 | Routed to Stereo Depth Receptacle Pin 21 or No Connect if not used. | |
| EGPIO[0] | L01 | FLAGB - Routed to Stereo Depth Connector Receptacle Pin 49 with pull up option to 1.8V with 0 ohm no stuff resistor | |
| EGPIO[1] | E03 | Pull up option to 1.8V with 0 ohm no stuff resistor | |
| EGPIO[2] | K01 | Pull up option to 1.8V with 0 ohm no stuff resistor | |
| EGPIO[3] | L02 | LASER_PWRDN - Routed to Stereo Depth Connector Receptacle Pin 45 with pull up option to 1.8V with 0 ohm no stuff resistor | |
| EGPIO[4] | M02 | Pull up to 1.8V with 4.99K resistor | |
| EGPIO[5] | J02 | Pull down option to GND with 0 Ohms no stuff resistor | |
| EGPIO[6] | D01 | Pull up option to 1.8V with 0 ohm no stuff resistor | |
| EGPIO[7] | E01 | Pull down to GND with 4.99K resistor | |
| EGPIO[8] | F01 | ISP_FCS – Color ISP EEPROM Chip Select. Also pulled up to 1.8V with 4.99K resistor | |
| EGPIO[9] | E02 | Pull up option to 1.8V with 0 ohm no stuff resistor | |

| Signal Name | Pad | Connection | ✓ |
|----------------------|-----|--|---|
| EGPIO[10] | J01 | Pull up option to 1.8V with 4.99K no stuff resistor | |
| EGPIO[11] | F03 | Pull up option to 1.8V with 4.99K no stuff resistor | |
| EGPIO[12] | K02 | Pull up option to 1.8V with 4.99K no stuff resistor | |
| EGPIO[13] | F02 | Pull up option to 1.8V with 0 ohm no stuff resistor | |
| USB | | | |
| USB_RXP | B02 | Intel®Vision Processor D4 Board supports USB Type-C connection to Host USB. Route as appropriate connection to Host USB | |
| USB_RXN | A03 | Intel®Vision Processor D4 Board supports USB Type-C connection to Host USB. Route as appropriate connection to Host USB. | |
| USB_TXP | B01 | Intel®Vision Processor D4 Board supports USB Type-C connection to Host USB. Route as appropriate connection to Host USB. | |
| USB_TXN | A02 | Intel®Vision Processor D4 Board supports USB Type-C connection to Host USB. Route as appropriate connection to Host USB. | |
| USB_DP | D03 | Intel®Vision Processor D4 Board supports USB Type-C connection to Host USB. Route as appropriate connection to Host USB. | |
| USB_DN | D02 | Intel®Vision Processor D4 Board supports USB Type-C connection to Host USB. Route as appropriate connection to Host USB. | |
| USB_ID | E05 | Intel®Vision Processor D4 Board supports USB Type-C connection to Host USB. Route as appropriate connection to Host USB. | |
| USB_RESREF | E04 | 200 ohm pull down to GND. (This resistor should be placed as close to ASIC as possible) | |
| MISCELLANIOUS | | | |
| LD_ON_OUT_XX | K13 | (RESERVED) No Connect | |
| MODSTROB | J15 | (RESERVED) No Connect | |
| MODSIGN | J14 | (RESERVED) No Connect | |
| LD_ERR | J13 | Connected to FF_RSTn (schematic) | |
| CLKXI | G1 | 24MHz XTAL. Refer to platform implementation schematic in Figure 10-2. | |
| CLKXO | H1 | 24MHz XTAL. Refer to platform implementation schematic in Figure 10-2. | |
| PRSTN | C3 | Platform implementation specific | |
| CW_CSR_PRSTN | P15 | No Connect | |
| PMU_PWR_EN | K3 | Enables VDD_PG voltage rail. | |

| Signal Name | Pad | Connection | ✓ |
|-------------------------|-----|---|---|
| DFU | C2 | Platform implementation specific | |
| ISP_SCL | M10 | (RESERVED) No Connect | |
| ISP_SDA | N9 | (RESERVED) No Connect | |
| VQPSQ | L3 | (RESERVED) No Connect | |
| VQPSM | M3 | (RESERVED) No Connect | |
| REFPADCLKP | D6 | (RESERVED) No Connect | |
| REFPADCLKM | E6 | (RESERVED) No Connect | |
| JTAG | | | |
| TDI | L13 | Routed to Test Point or pulldown resistor of 4.7-10KOhm if JTAG is not used. | |
| TDO | L14 | Routed to Test Point | |
| TCLK | K14 | Routed to Test Point or pulldown resistor of 4.7-10KOhm if JTAG is not used. | |
| TMS | K15 | Routed to Test Point or pulldown resistor of 4.7-10KOhm if JTAG is not used. | |
| TRSTN | L15 | Routed to Test Point | |
| POWER AND GROUND | | | |
| VDD | | 0.9V | |
| VDD_PG | | 0.9V | |
| USB_DVDD | | 0.9V | |
| VPTX0 | | 0.9V | |
| VP | | 0.9V | |
| *_AVDD | | 1.8V | |
| VDDPLL | | 0.9V | |
| VDDTS | | 1.8V | |
| VDDPST18 | | 1.8V | |
| USB_VDD330 | | 3.3V | |
| VBUS0 | | VBUS Power Monitor Signal. VBUS0 signal level is at $VBUS * (200k / (200k + 30k))$ using external voltage divider | |
| VSS | | Ground | |
| *_AGND | | Ground | |

Figure 12-1. Vision Processor D4 Laser PWM Reference Platform Schematic

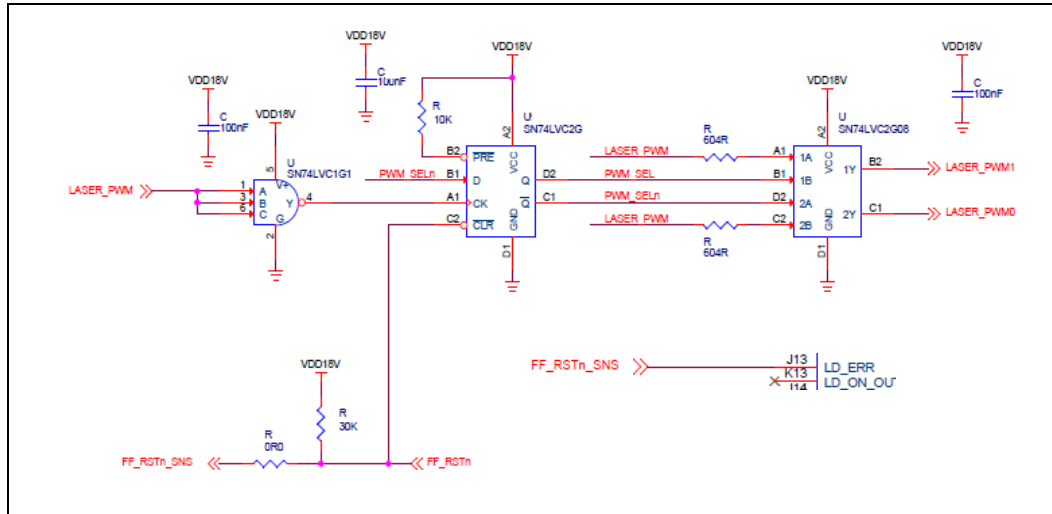
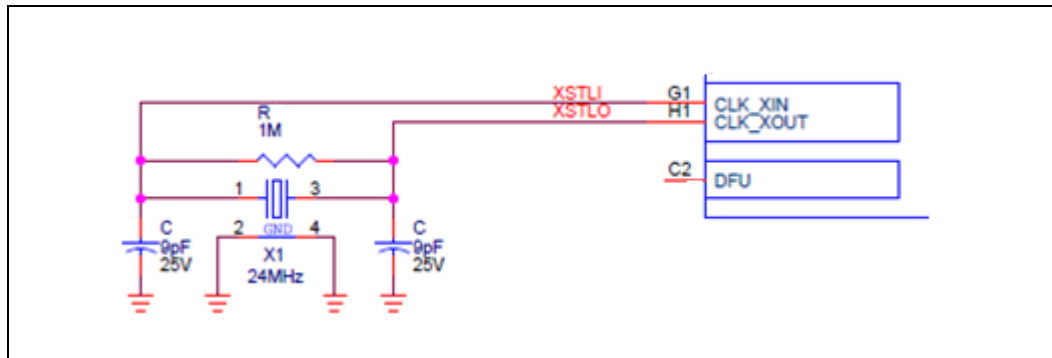

Figure 12-2. Vision Processor D4 24MHz Crystal Clock Reference Platform Schematic



12.1 Power Delivery

The DC-DC power circuitry discussed in this section must be followed for Vision Processor D4 on Motherboard designs. TPS62085R DC-DC converter (www.ti.com) generates 0.9V and SC21150 (www.semtech.com) generates 1.8V and 3.3V voltage rails from 5V to power Vision Processor D4, Stereo Depth Module.

Figure 12-3. DC-DC Reference Platform Schematic (3.3V, 1.8V, 0.9V)

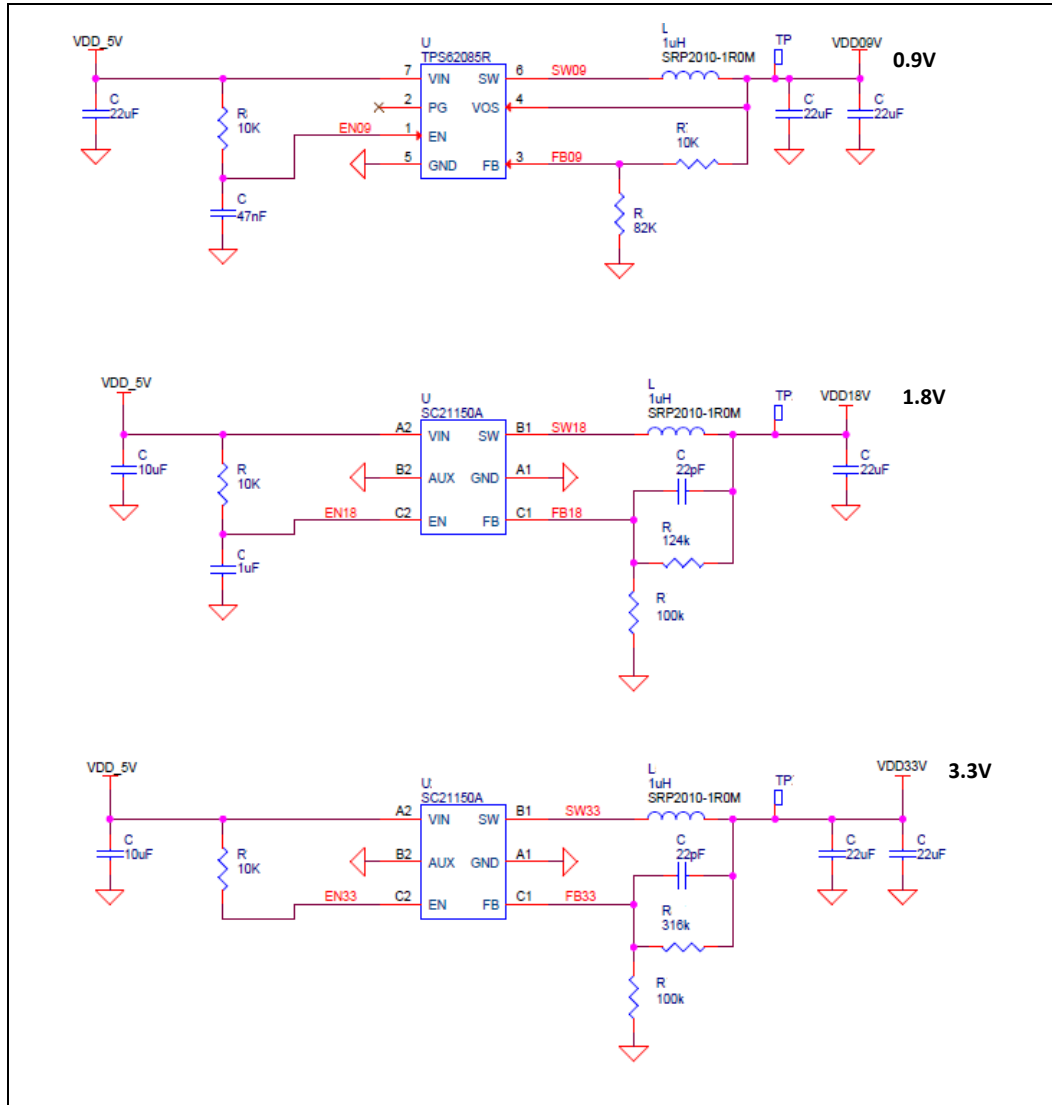

Figure 12-4. Vision Processor D4 VDD_PG and AVDD Reference Platform Schematic

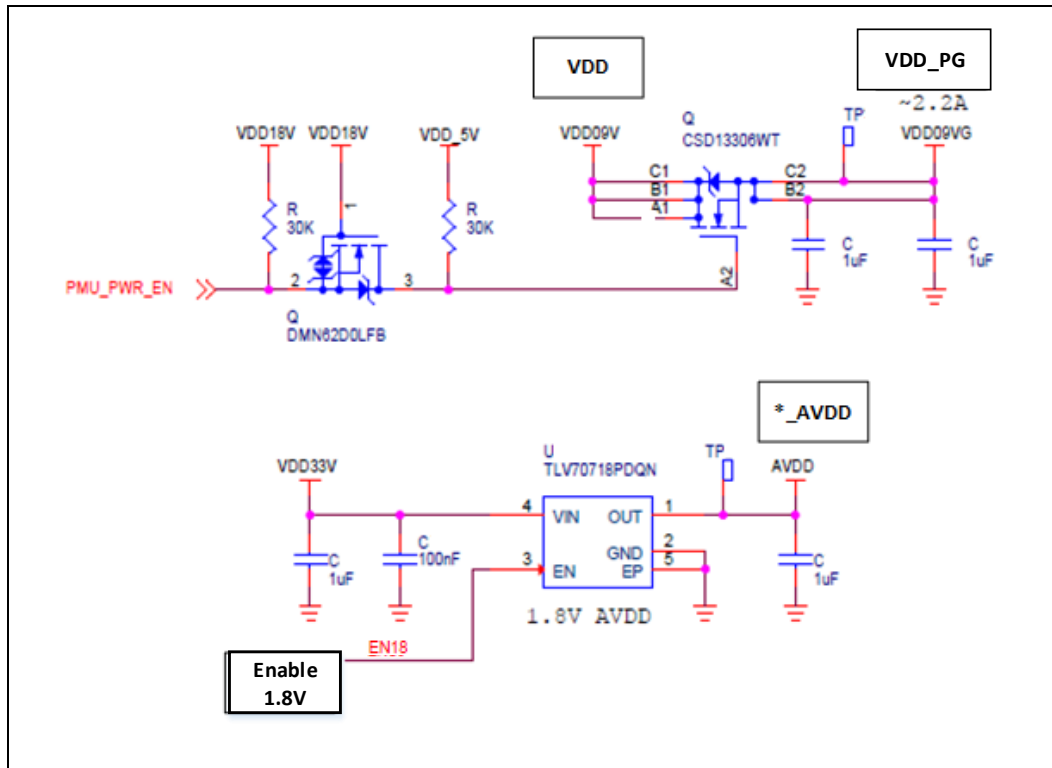

Table 12-2. Vision Processor D4 Decoupling and Filter Requirements

| Voltage Ball Name | Decoupling | Filter | Notes |
|------------------------------|------------|--|-------|
| VDD | 4X 100nF | | |
| VDD_PG | 8X 100nF | | |
| USB_DVDD | 2X 100nF | 1X 100nF 1X FERRITE BEAD 120 OHM | |
| VPTX0 | | | |
| VP | | | |
| *AVDD | 1X 100nF | | |
| VDDPLL | 1X 100nF | 1X 100nF 1X FERRITE BEAD 120 OHM | |
| VDDTS | 1X 100nF | | |
| VDDPST18 (Left and Right) | 1X 100nF | | |
| USB_VDD330 | 1X 100nF | | |
| VBUS0 | | | |

13 Appendix B- Cover Material

Cover materials placed over the camera sensor must be carefully selected to avoid impacting software performance. The following parameters are an example of a suitable cover material. Other solutions are also acceptable but careful design and validation work should be done to verify a solution will perform adequately.

Table 13-1. Example: Cover Material Parameters

| Specification | Recommendation | Notes |
|-------------------------------|---|---------------------------------|
| Hardness | 6H | Prevent Scratches |
| Flatness | 0.005mm | Minimize Distortion |
| Distance From Lens to Cover | Less than 8mm (D410/D415) Less than 2mm (D430) | Cover Material thickness of 1mm |
| Thickness of Cover | 0.55mm ± 0.03mm | |
| Coatings | AR inside and outside | Avoid Reflections |
| Transmission Wavelength Range | 400 to 865 (Visible and Infrared) @ 98% transmission rate or higher at all viewing and transmitting angles | |
| Cover Tilt Tolerance | ± 1.0° | |

§§