

**TYPES
B, D, & E**

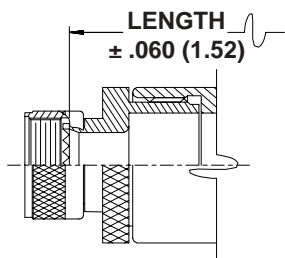

STYLE 2

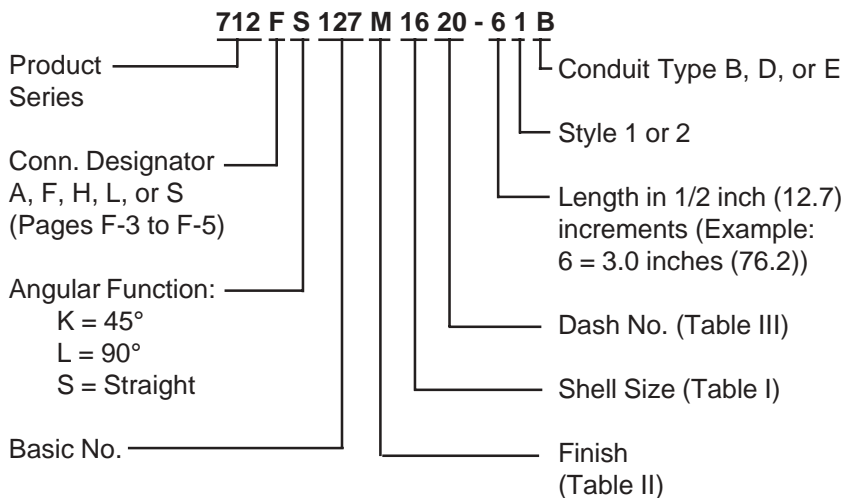
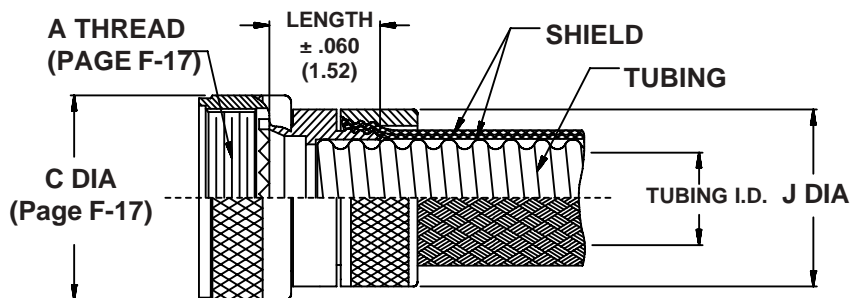

STRAIGHT

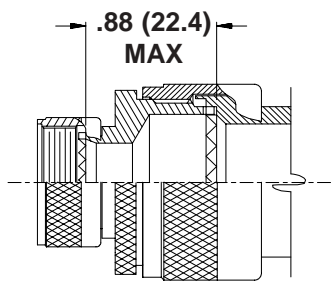

**STYLE 2
(45° & 90°)**

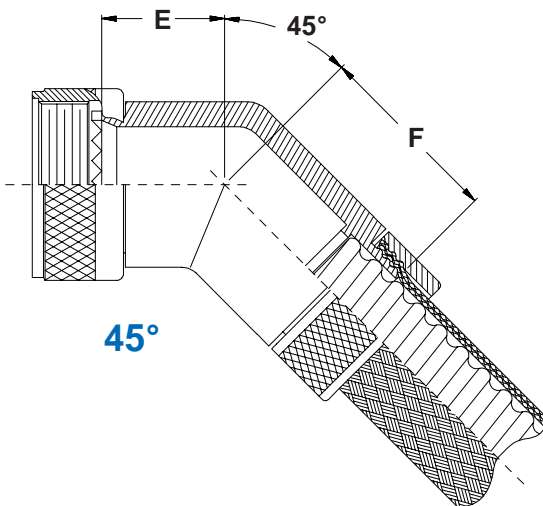

45°

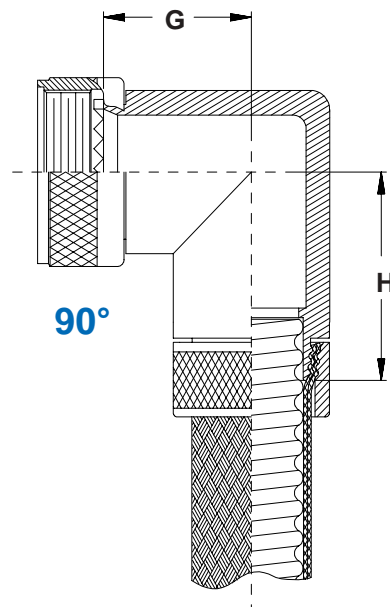

90°

712-127 - Types B, D & E
Straight, 45° & 90° Non-Environmental User-Installable
Connector Fitting for Series 74 Helical Convoluted Tubing



SHELL SIZE		E	F	G	H
A,F,L,S	H	MAX	MAX	MAX	MAX
08	09	.639 (16.2)	.950 (24.1)	.750 (19.1)	1.060 (26.9)
10	11	.664 (16.9)	.980 (24.9)	.810 (20.6)	1.120 (28.4)
12	13	.688 (17.5)	1.000 (25.4)	.870 (22.1)	1.180 (30.0)
14	15	.705 (17.9)	1.030 (26.2)	.920 (23.4)	1.250 (31.8)
16	17	.732 (18.6)	1.050 (26.7)	.980 (24.9)	1.310 (33.3)
18	19	.748 (19.0)	1.060 (26.9)	1.020 (25.9)	1.330 (33.8)
20	21	.773 (19.6)	1.080 (27.4)	1.080 (27.4)	1.390 (35.3)
22	23	.800 (20.3)	1.120 (28.4)	1.140 (29.0)	1.470 (37.3)
24	25	.823 (20.9)	1.150 (29.2)	1.200 (30.5)	1.540 (39.1)
28	--	1.041 (26.4)	1.320 (33.5)	1.480 (37.6)	1.780 (45.2)
32	--	1.092 (27.7)	1.360 (34.5)	1.610 (40.9)	1.870 (47.5)
36	--	1.138 (28.9)	1.410 (35.8)	1.720 (43.7)	1.980 (50.3)

SYMBOL	FINISH
B	Olive Drab over Cadmium Plate
J	Gold Iridite over Cadmium Plate over Nickel
M	Electroless Nickel
N	Olive Drab over Cadmium Plate over Nickel
NC	Zinc-Cobalt, Olive Drab
NF	Olive Drab over Cadmium Plate over Electroless Nickel (500 Hour Salt Spray)
T	Bright Dip Cadmium Plate over Nickel

DASH NO.	TUBING I.D.		J MAX
	MIN	MAX	
06	.181 (4.6)	.188 (4.8)	.910 (23.1)
09	.273 (6.9)	.281 (7.1)	1.000 (25.4)
10	.306 (7.8)	.312 (7.9)	1.032 (26.2)
12	.364 (9.2)	.375 (9.5)	1.095 (27.8)
14	.427 (10.8)	.437 (11.1)	1.167 (29.6)
16	.485 (12.3)	.500 (12.7)	1.220 (31.0)
20	.608 (15.4)	.625 (15.9)	1.345 (34.2)
24	.730 (18.5)	.750 (19.1)	1.470 (37.3)
28	.860 (21.8)	.875 (22.2)	1.595 (40.5)
32	.975 (24.8)	1.000 (25.4)	1.720 (43.7)
40	1.210 (30.7)	1.250 (31.8)	1.970 (50.0)
48	1.437 (36.5)	1.500 (38.1)	2.220 (56.4)
56	1.688 (42.9)	1.750 (44.5)	2.470 (62.7)
64	1.937 (49.2)	2.000 (50.8)	2.720 (69.1)

NOTES:

1. Metric dimensions (mm) are in parentheses.
2. Tubing shown for reference only.
3. When tubing I.D. max exceeds inside diameter of connector shell, style 2 may be supplied. Refer to pages F-15 and F-16.