

PRODUCT DATA DRAWING

REVISION HISTORY			
REV	DESCRIPTION	DATE	APPROVED
-	DCN 39326	08/12	STW
A	REV. DCN 49080	06/05/19	STW

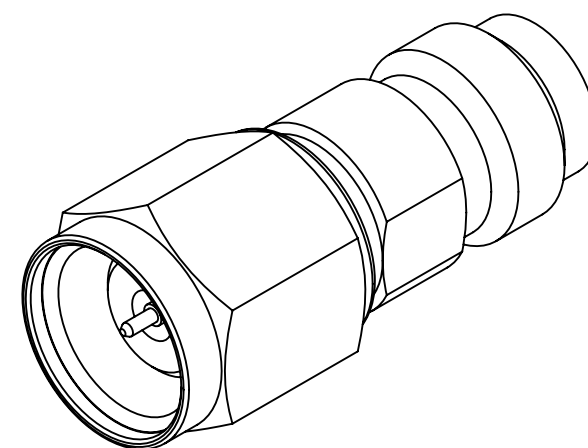
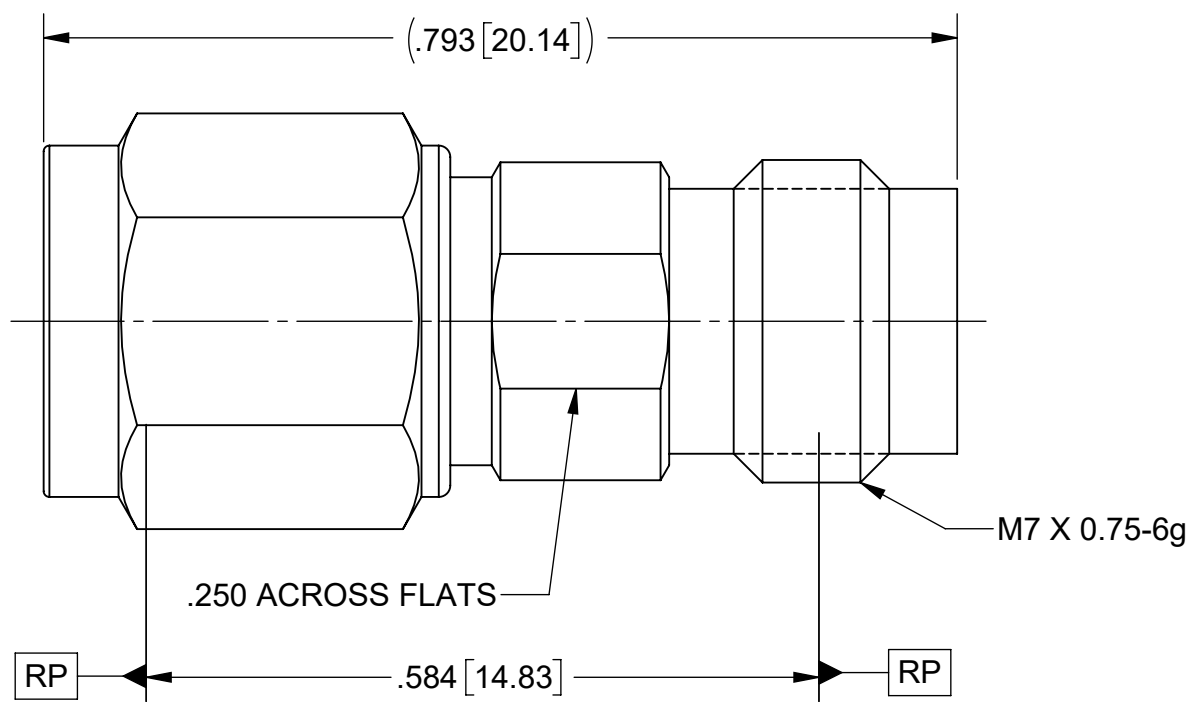
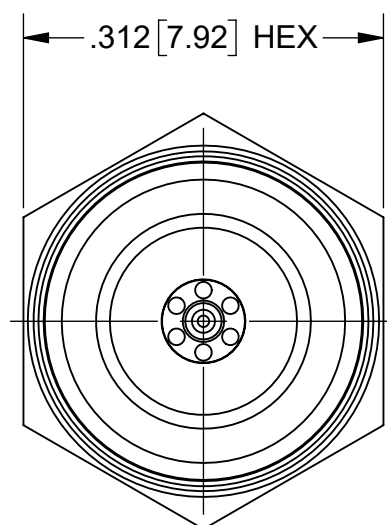

MATERIAL:
BODY, INSERTS & COUPLING NUT: STAINLESS STEEL PER AMS 5640, ALLOY UNS S30300, TYPE 1 OOR ASTM A582, TYPE 303, CONDITION A.
LOCK RING: BERYLLIUM COPPER PER ASTM B194, B196 OR B197 ALLOY No. UNS C17300.
CONTACT: BERYLLIUM COPPER PER ASTM B196, ALLOY No. UNS C17300, TD04.
DIELECTRIC BEADS: PEI (ULTEM 1000) PER ASTM D5205.

FINISH:
BODY, INSERTS & COUPLING NUT: PASSIVATED PER AMS 2700.
CONTACT: GOLD PER ASTM B488, TYPE II, CODE C, CLASS 1.27 OVER NICKEL PER AMS-QQ-N-290, CLASS 1, .00005" MIN.

PERFORMANCE:
FREQ. RANGE: DC TO 65 GHz

MATERIAL: SEE NOTES	DIMENSIONS ARE IN INCHES TOLERANCES: FRACTIONAL: ±1/64 ANGULAR: X° ±1'0" X'X' ±15'	UNLESS OTHERWISE SPECIFIED 1) ALL DIMENSIONS ARE IN INCHES (MILLIMETERS) 2) ALL DIMENSIONS ARE AFTER PLATING. 3) BREAK CORNERS & EDGES .005 R. MAX. 4) CHAM. 1ST & LAST THREADS. 5) SURFACE ROUGHNESS 63-MIL-STD-10. 6) DIA.'S ON COMMON CENTERS TO BE CONCENTRIC WITHIN .005 T.I.R. 7) REMOVE ALL BURRS	SV Microwave, Inc. 2400 Centrepark West Drive, Suite 100 West Palm Beach, FL 33409 TITLE: ADAPTER 1.85mm MALE TO 1.85mm FEMALE
FINISH: SEE NOTES	DECIMAL: X ±.030 .XX ±.010 .XXX ±.005		
SURFACE AREA: N/A	INTERPRET DIMENSIONS AND TOLERANCES PER ASME Y14.5M - 1994	DRAWN: FSG 08/28/12	SIZE: B CAGE CODE: 95077 DWG. NO.: SF1133-6010
PROPRIETARY THE INFORMATION CONTAINED IN THIS DRAWING IS THE SOLE PROPERTY OF SV MICROWAVE, INC. ANY REPRODUCTION IN PART OR AS A WHOLE WITHOUT THE WRITTEN PERMISSION OF SV MICROWAVE, INC IS PROHIBITED.	THIRD ANGLE PROJECTION 	CHECKED: STW 08/28/12	SCALE: 6:1
		APPROVED: STW 08/28/12	SHEET 1 OF 1