

Integrated LED Driver with Average-Mode Current Control

Features

- ▶ 3% accurate LED current
- ▶ Integrated 60V, 0.8Ω MOSFET
- ▶ Low sensitivity to external component variation
- ▶ Single resistor LED current setting
- ▶ Fixed off-time control
- ▶ PWM dimming input
- ▶ Output short circuit protection with skip mode
- ▶ Over-temperature protection
- ▶ Available in compact 8-Lead MSOP and 8-Lead DFN packages

Applications

- ▶ DC/DC or AC/DC LED drivers
- ▶ RGB backlighting drivers for flat panel displays
- ▶ General purpose constant current source
- ▶ Signage and decorative LED lighting
- ▶ Chargers

General Description

The HV9967B is an average-mode current control LED driver IC operating in a constant off-time mode.

The IC features an integrated 60V, 0.8Ω MOSFET that can be used as a stand-alone buck converter switch, or connected as a source driver for driving an external high-voltage depletion-mode MOSFET. The HV9967B is powered through its switching output when the integrated switch is off. Hence, the same external MOSFET can be used as a high-voltage linear regulator for powering the IC.

The LED current is programmed with one external resistor. The average-mode current control method does not produce a peak-to-average error, and therefore greatly improves current accuracy and line and load regulation of the LED current without any need for loop compensation or direct sensing of the LED current at a high-voltage potential. The auto-zero circuit cancels the effects of the input offset voltage and of the propagation delay of the current sense comparator.

Typical Application Circuit

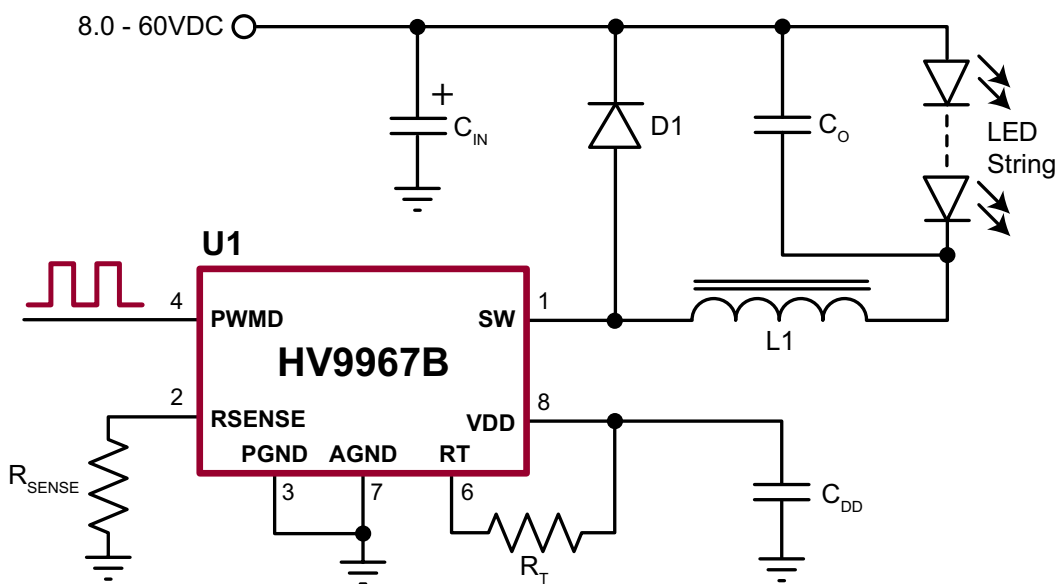

Ordering Information

Part Number	Package Options	Packing
HV9967BK7-G	8-Lead DFN (3x3mm)	3000/Reel
HV9967BMG-G	8-Lead MSOP	2500/Reel

-G indicates package is RoHS compliant ("Green")



Absolute Maximum Ratings*

Parameter	Value
SW to GND	-0.5V to +65V
VDD to GND	-0.3V to 6.0V
Other I/O to GND	-0.3V to (V _{DD} + 0.3V)
R _{TP} I _{SET}	2.0mA
Continuous power dissipation (T _A = +25°C)	
8-Lead DFN (K7)	1.6W
8-Lead MSOP (MG)	350mW
Junction temperature	-40°C to +150°C
Storage temperature range	-65°C to +150°C

Stresses beyond those listed under "Absolute Maximum Ratings" may cause permanent damage to the device. These are stress ratings only, and functional operation of the device at these or any other conditions beyond those indicated in the operational sections of the specifications is not implied. Exposure to absolute maximum rating conditions for extended periods may affect device reliability.

Typical Thermal Resistance

Package	θ_{ja}
8-Lead DFN	37°C/W
8-Lead MSOP	216°C/W

Electrical Characteristics

(The * denotes specifications which apply over the full operating ambient temperature range of -40°C < T_A < 125°C. Otherwise specifications are at T_A = 25°C. V_{SW} = 10V/10mA, V_{DD} = 5.0V unless otherwise noted)

Sym	Description	Min	Typ	Max	Units	Conditions
Input						
V _{SWDC}	Input DC supply voltage range	*	8.0	-	60	V DC input voltage
I _{INSD}	Shut-down mode supply current	-	-	0.5	1.0	mA Pin PWMD to GND

Notes:

Not production tested; guaranteed by design or characterization.

* Specifications apply over the full operating ambient temperature range of -40°C < T_A < +125°C.

Pin Configurations

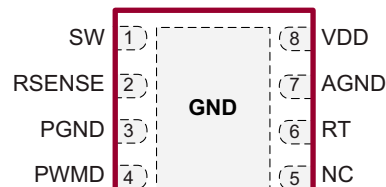

8-Lead DFN (K7)
(top view)

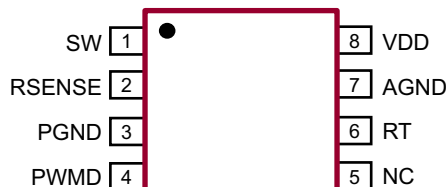

8-Lead MSOP (MG)
(top view)

Product Marking



Y = Last Digit of Year Sealed
W = Code for Week Sealed
L = Lot Number
— = "Green" Packaging

Package may or may not include the following marks: Si or

8-Lead DFN (K7)

Top Marking



L = Lot Number
YY = Year Sealed
WW = Week Sealed
— = "Green" Packaging

Bottom Marking



Package may or may not include the following marks: Si or

8-Lead MSOP (MG)

Electrical Characteristics (cont.)

(The * denotes specifications which apply over the full operating ambient temperature range of $-40^{\circ}\text{C} < T_A < 125^{\circ}\text{C}$. Otherwise specifications are at $T_A = 25^{\circ}\text{C}$. $V_{SW} = 10\text{V}/10\text{mA}$, $V_{DD} = 5.0\text{V}$ unless otherwise noted)

Sym	Description	Min	Typ	Max	Units	Conditions
-----	-------------	-----	-----	-----	-------	------------

Internal Regulator

VDD	Internally regulated voltage	-	4.70	5.00	5.20	V	PWMD = V_{DD} ; $R_T = 100\text{k}\Omega$
UVLO	V_{DD} undervoltage lockout threshold	*	4.10	-	4.70	V	V_{DD} rising, as needed to ensure $I_{C(MIN)}$
ΔUVLO	V_{DD} undervoltage lockout hysteresis	-	-	150	-	mV	V_{DD} falling

PWM Dimming

$V_{EN(LO)}$	PWMD input low voltage	*	-	-	0.8	V	---
$V_{EN(HI)}$	PWMD input high voltage	*	2.0	-	-	V	---
R_{EN}	Internal pull down resistance at PWMD	-	50	100	150	k Ω	$V_{PWMD} = 5.0\text{V}$

Current Control

$V_{CS(TH)}$	R_{SENSE} current threshold	-	243	-	257	mV	---
dV_{CS}/dt°	Temperature regulation	-	-	0.1	-	mV/ $^{\circ}\text{C}$	
T_{BLANK}	Current sense blanking interval	*	140	-	290	ns	---
$T_{ON(MIN)}$	Minimum ON-time	*	-	-	950	ns	$V_{RSENSE} = V_{CS(TH)} + 50\text{mV}$
D_{MAX}	Maximum steady-state duty cycle	*	80	-	-	%	Reduction in output LED current occurs beyond this duty cycle due to saturation of T2 timers.

Short Circuit Protection

$V_{CS(SHORT)}$	Hiccup threshold voltage at R_{SENSE}	*	355	-	440	mV	---
T_{DELAY}	Current limit delay R_{SENSE} to SW-OFF	-	-	-	150	ns	$V_{RSENSE} = V_{CS(SHORT)} + 50\text{mV}$
T_{HICCUP}	Hiccup time	-	-	800	-	μs	---
$T_{ON(MIN)}$	Minimum ON-time (short circuit)	-	-	-	400	ns	$V_{RSENSE} = V_{CS(SHORT)} + 50\text{mV}$

T_{OFF} Timer

T_{OFF}	OFF time	*	28	40	48	μs	$R_T = 400\text{k}\Omega$
			7.0	10	12		$R_T = 100\text{k}\Omega$
			0.7	1.0	1.2		$R_T = 10\text{k}\Omega$

SW Output

R_{ON}	ON resistance	-	-	0.8	-	Ω	$V_{DD} = 5.0\text{V}$
I_C	Continuous current	*	0.75	-	-	A	$V_{DD} = 4.75\text{V}$, $V_{RSENSE} = 370\text{mV}$, $V_{SW} = 10\text{V}$

Over-temperature Protection

T_{SD}	Shut-down temperature	#	125	-	-	$^{\circ}\text{C}$	---
ΔT_{SD}	Hysteresis	#	-	20	-	$^{\circ}\text{C}$	---

Notes:

Not production tested; guaranteed by design or characterization.

* Specifications apply over the full operating ambient temperature range of $-40^{\circ}\text{C} < T_A < +125^{\circ}\text{C}$.

Functional Block Diagram

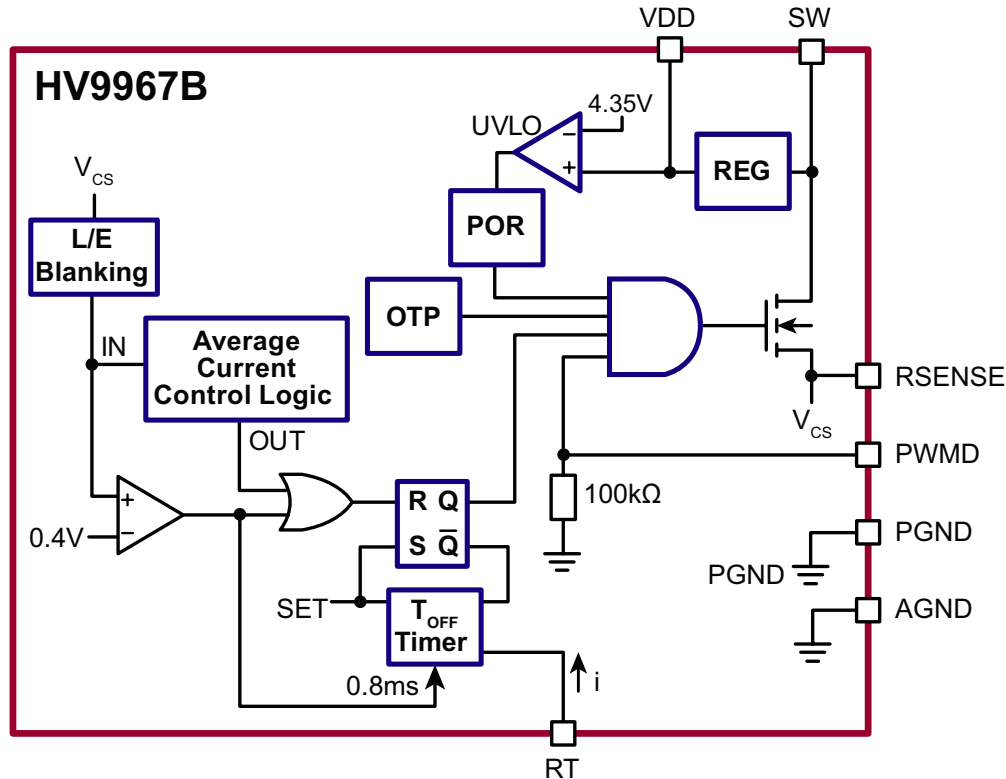

Application Information

General description

The HV9967B employs Supertex' proprietary control scheme, achieving fast and very accurate control of average current in the buck inductor through sensing the switch current only. No compensation of the current control loop is required. The LED current response to PWM input is similar to that of the peak-current control ICs, such as HV9910B. The inductor current ripple amplitude does not affect this control scheme significantly, and therefore, the LED current is independent of the variation in inductance, switching frequency or output voltage. Constant off-time control of the buck converter is used for stability and to reduce input voltage regulation of the LED current.

OFF Timer

The timing resistor connected to RT determines the off-time of the gate driver, and it must be wired to VDD. The equation governing the off-time of the GATE output is given by:

$$T_{OFF} = R_T \cdot 100pF \quad (1)$$

within the range of $10k\Omega \leq R_T \leq 400k\Omega$.

Average Current Control Feedback and Output Short Circuit Protection

The constant-current control feedback derives the average current signal from the source current of the switching MOSFET. This current is detected using a sense resistor at the RSENSE pin. The feedback operates in a fast open-loop mode. No compensation is required. Output current is programmed simply as:

$$I_{LED} = \frac{0.25V}{R_{CS}} \quad (2)$$

The above equation is only valid for continuous conduction of the output inductor. It is a good practice to design the inductor such that the switching ripple current in it is 30~40% of its average full load DC current peak-to-peak. Hence, the recommended inductance can be calculated as:

$$L_O = \frac{V_{O(MAX)} \cdot T_{OFF}}{0.4 \cdot I_O} \quad (3)$$

The duty-cycle range of the current control feedback is limited to $D \leq 0.8$. A reduction in the LED current may occur when the LED string voltage V_O is greater than 80% of the input voltage V_{IN} of the HV9967B LED driver.

Reducing the output LED voltage V_O below $V_{O(MIN)} = V_{IN} \cdot D_{MIN}$, where $D_{MIN} = 0.8\mu s / (T_{OFF} + 0.8\mu s)$, may also result in the loss of regulation of the LED current. This condition, however, causes increase in the LED current and can potentially trip the short-circuit protection comparator threshold.

The short circuit protection comparator trips when the voltage at RSENSE exceeds $0.4V$. When this occurs, the SW off-time $T_{HICCUP} = 800\mu s$ is generated to prevent stair-casing of the inductor current and potentially its saturation due to insufficient output voltage. The typical short-circuit current is shown in the waveform of Fig. 1.

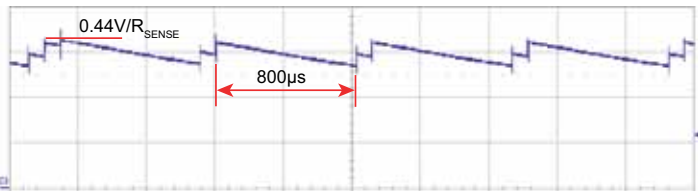

Fig.1. Short-circuit inductor current.

A leading-edge blanking delay is provided at RSENSE to prevent false triggering of the current feedback and the short circuit protection.

SW Input and Linear Regulator

HV9967B includes an integrated 60V, 0.8Ω switching MOSFET at the SW input. The power for the IC is supplied from a linear 5.0V regulator that is also derived from the SW input.

PWM Dimming

The HV9967B features a TTL compatible dimming input PWM. Applying a square-wave voltage to PWMD will modulate the duty ratio of the LED current accordingly. The rising and falling edges are limited by the current slew rate in the inductor. The first switching cycle is terminated upon reaching the 250mV level at RSENSE. The circuit will reach the steady state within 3~4 switching cycles regardless of the switching frequency.

Over-Temperature Protection

The HV9967B includes over-temperature protection. Typically, when the junction temperature exceeds 145°C, switching of the SW input is disabled. The switching resumes when the temperature falls by approximately 20°C from the trip point.

Pin Description

Pin #	Function	Description
1	SW	Drain of 60V 0.8Ω NDMOS switch and input of H/V regulator.
2	RSENSE	Source of NDMOS switch and current sense input. Connect a resistor to GND to program the output current and short circuit thresholds.
3	PGND	Power ground. Must be wired to AGND on PCB.
4	PWMD	PWM dimming input. This TTL input enables switching of SW when in high state.
5	NC	No connection.
6	RT	Resistor connected between RT and VDD programs the off-time of SW.
7	AGND	Analog ground (0V).
8	VDD	Power supply for all internal circuits. Bypass with a low ESR capacitor to PGND (>0.5µF). Connect GATE of external depletion-mode NFET for high-voltage operation.

8-Lead DFN Package Outline (K7)

3.00x3.00mm body, 0.80mm height (max), 0.65mm pitch

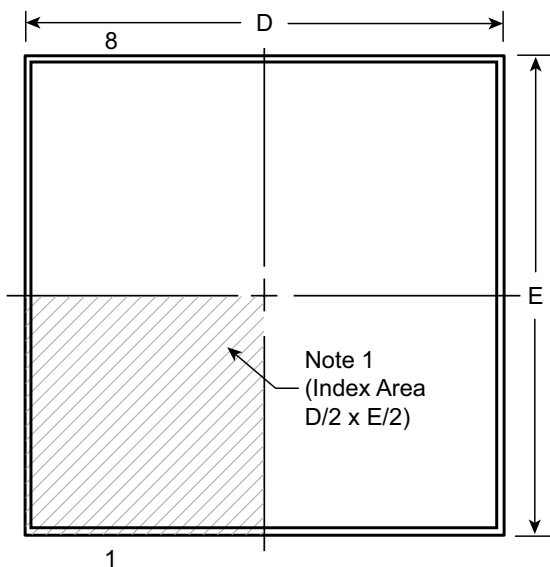

Top View

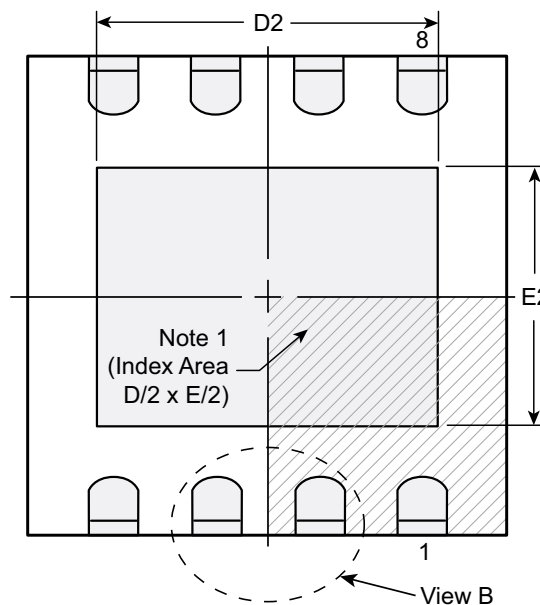

Bottom View

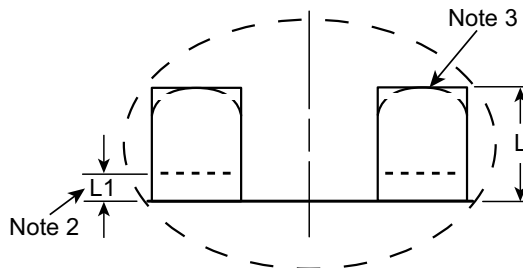
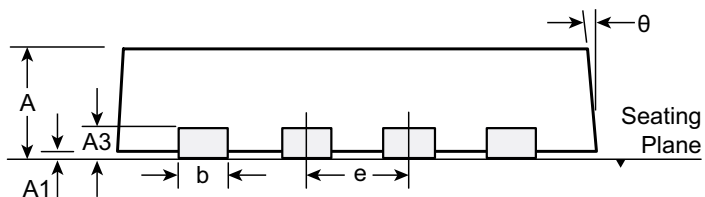

Notes:

1. A Pin 1 identifier must be located in the index area indicated. The Pin 1 identifier can be: a molded mark/identifier; an embedded metal marker; or a printed indicator.
2. Depending on the method of manufacturing, a maximum of 0.15mm pullback (L1) may be present.
3. The inner tip of the lead may be either rounded or square.

Symbol		A	A1	A3	b	D	D2	E	E2	e	L	L1	θ
Dimension (mm)	MIN	0.70	0.00	0.20 REF	0.25	2.85*	1.60	2.85*	1.35	0.65 BSC	0.30	0.00*	0°
	NOM	0.75	0.02		0.30	3.00	-	3.00	-		0.40	-	-
	MAX	0.80	0.05		0.35	3.15*	2.50	3.15*	1.75		0.50	0.15	14°

JEDEC Registration MO-229, Variation WEEC-2, Issue C, Aug. 2003.

* This dimension is not specified in the JEDEC drawing.

Drawings not to scale.

Supertex Doc. #: DSPD-8DFNK73X3P065, Version C081109.

8-Lead MSOP Package Outline (MG)

3.00x3.00mm body, 1.10mm height (max), 0.65mm pitch

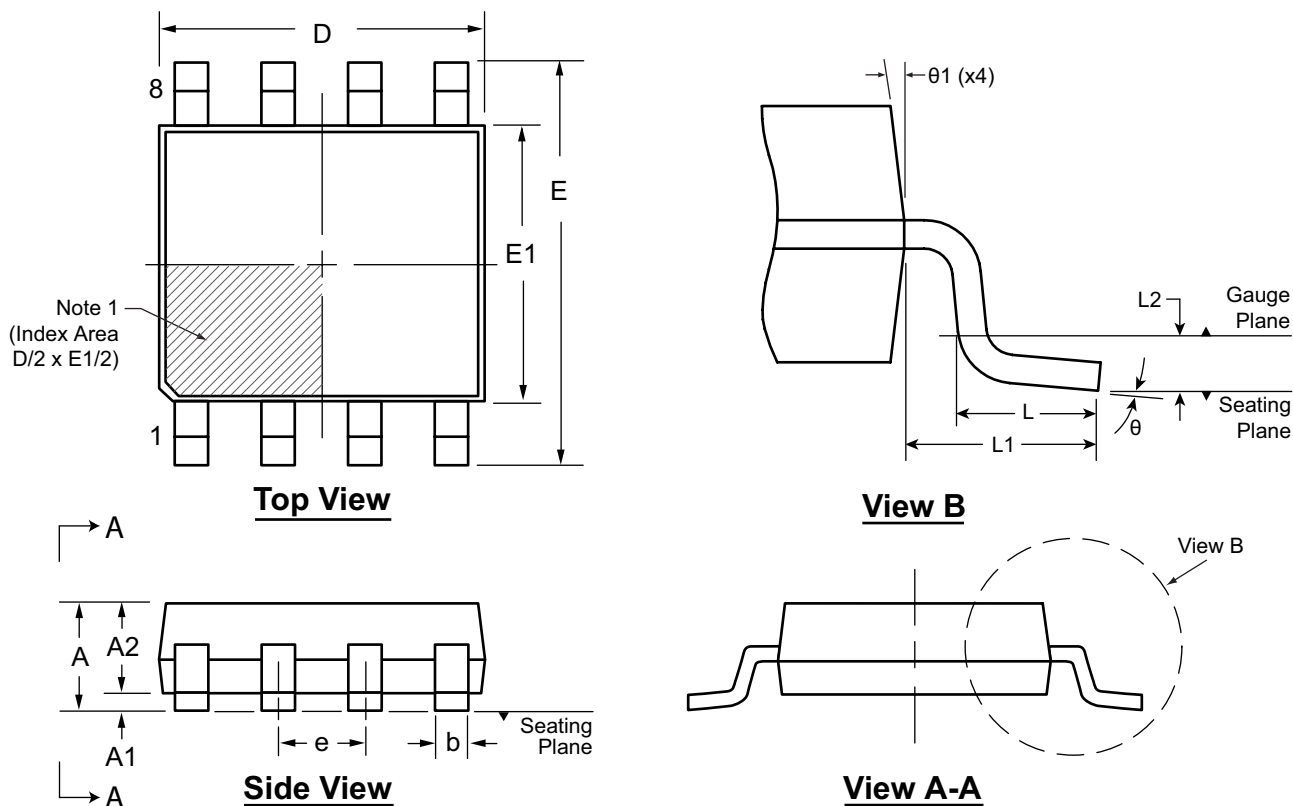

Note:
 1. A Pin 1 identifier must be located in the index area indicated. The Pin 1 identifier can be: a molded mark/identifier; an embedded metal marker; or a printed indicator.

Symbol		A	A1	A2	b	D	E	E1	e	L	L1	L2	θ	θ1
Dimension (mm)	MIN	0.75*	0.00	0.75	0.22	2.80*	4.65*	2.80*	0.65 BSC	0.40	0.95 REF	0.25 BSC	0°	5°
	NOM	-	-	0.85	-	3.00	4.90	3.00		0.60			-	-
	MAX	1.10	0.15	0.95	0.38	3.20*	5.15*	3.20*		0.80			8°	15°

JEDEC Registration MO-187, Variation AA, Issue E, Dec. 2004.

* This dimension is not specified in the JEDEC drawing.

Drawings are not to scale.

Supertex Doc. #: DSPD-8MSOPMG, Version H041309.

(The package drawing(s) in this data sheet may not reflect the most current specifications. For the latest package outline information go to <http://www.supertex.com/packaging.html>.)

Supertex inc. does not recommend the use of its products in life support applications, and will not knowingly sell them for use in such applications unless it receives an adequate "product liability indemnification insurance agreement." **Supertex inc.** does not assume responsibility for use of devices described, and limits its liability to the replacement of the devices determined defective due to workmanship. No responsibility is assumed for possible omissions and inaccuracies. Circuitry and specifications are subject to change without notice. For the latest product specifications refer to the **Supertex inc.** (website: <http://www.supertex.com>)