



## SY89295U

### 2.5V/3.3V 1.5GHz Precision LVPECL Programmable Delay

## General Description

The SY89295U is a programmable delay line that delays the input signal using a digital control signal. The delay can vary from 3.2ns to 14.8ns in 10ps increments. In addition, the input signal is LVPECL, uses either a 2.5V  $\pm 5\%$  or 3.3V  $\pm 10\%$  power supply, and is guaranteed over the full industrial temperature range ( $-40^{\circ}\text{C}$  to  $+85^{\circ}\text{C}$ ).

The delay varies in discrete steps based on a control word. The control word is 10-bits long and controls the delay in 10ps increments. The eleventh bit is D[10] and is used to simultaneously cascade the SY89295U which allows for a larger delay range. In addition, the input pins IN and /IN default to an equivalent low state when left floating. Further, for maximum flexibility, the control register interface accepts CMOS or TTL level signals.

For applications that require an analog delay input, see the SY89296L which is a programmable delay chip with fine tune control. The SY89295U and SY89296U are part of Micrel's high-speed, Precision Edge<sup>®</sup> product line.

Data sheets and support documentation can be found on Micrel's web site at: [www.micrel.com](http://www.micrel.com).



Precision Edge<sup>®</sup>

## Features

- Precision LVPECL programmable delay line
- Guaranteed AC performance over temperature and voltage:
  - $>1.5\text{GHz } f_{\text{MAX}}$
  - $<160\text{ps}$  rise/fall times
- Low-jitter design:
  - $<10\text{ps}_{\text{PP}}$  total jitter
  - $<2\text{ps}_{\text{RMS}}$  cycle-to-cycle jitter
  - $<1\text{ps}_{\text{RMS}}$  random jitter
- Programmable delay range: 3.2ns to 14.8ns in 10ps increments
- Increased monotonicity over the MIC100EP195
- $\pm 10\text{ps}$  INL
- $V_{\text{BB}}$  output reference voltage
- Parallel inputs accepts LVPECL or CMOS/LVTTL
- Low voltage operation: 2.5V  $\pm 5\%$  and 3.3V  $\pm 10\%$
- Industrial  $-40^{\circ}\text{C}$  to  $+85^{\circ}\text{C}$  temperature range
- Available in 32-pin (5mm  $\times$  5mm) MLF<sup>®</sup> and 32-pin TQFP packages

## Applications

- Clock de-skewing
- Timing adjustments
- Aperture centering

Precision Edge is a registered trademark of Micrel, Inc  
MicroLeadFrame and MLF are registered trademarks of Amkor, Inc.

Micrel Inc. • 2180 Fortune Drive • San Jose, CA 95131 • USA • tel +1 (408) 944-0800 • fax + 1 (408) 474-1000 • <http://www.micrel.com>

March 2011

M9999-032511  
[hbwhelp@micrel.com](mailto:hbwhelp@micrel.com) or (408) 955-1690

## Ordering Information<sup>(1)</sup>

Part Number	Package Type	Operating Range	Package Marking	Lead Finish
SY89295UMI	MLF-32	Industrial	SY89295U	Sn-Pb
SY89295UMI TR <sup>(2)</sup>	MLF-32	Industrial	SY89295U	Sn-Pb
SY89295UTI	T32-1	Industrial	SY89295U	Sn-Pb
SY89295UTITR <sup>(2)</sup>	T32-1	Industrial	SY89295U	Sn-Pb
SY89295UMG <sup>(3)</sup>	MLF-32	Industrial	SY89295U with Pb-Free bar-line indicator	Pb-Free NiPd Au
SY89295UMGTR <sup>(2, 3)</sup>	MLF-32	Industrial	SY89295U with Pb-Free bar-line indicator	Pb-Free NiPd Au
SY89295UTG <sup>(3)</sup>	T32-1	Industrial	SY89295U with Pb-Free bar-line indicator	Pb-Free NiPd Au
SY89295UTGTR <sup>(2, 3)</sup>	T32-1	Industrial	SY89295U with Pb-Free bar-line indicator	Pb-Free NiPd Au

**Notes:**

1. Contact factory for die availability. Dice are guaranteed at T<sub>A</sub> = 25°C, DC electricals only.
2. Tape and Reel.
3. Pb-Free package is recommended for new designs.

## Pin Configuration

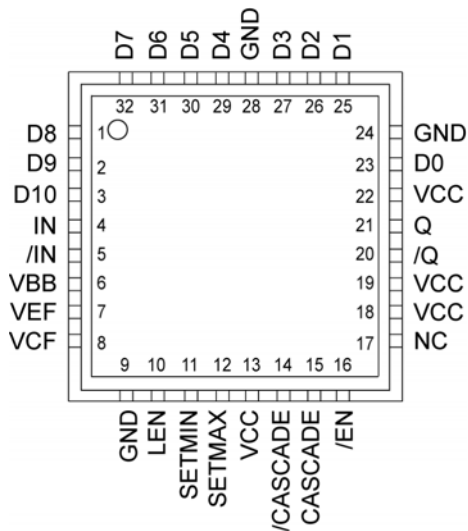

**32-Pin MLF® (MLF-32)**

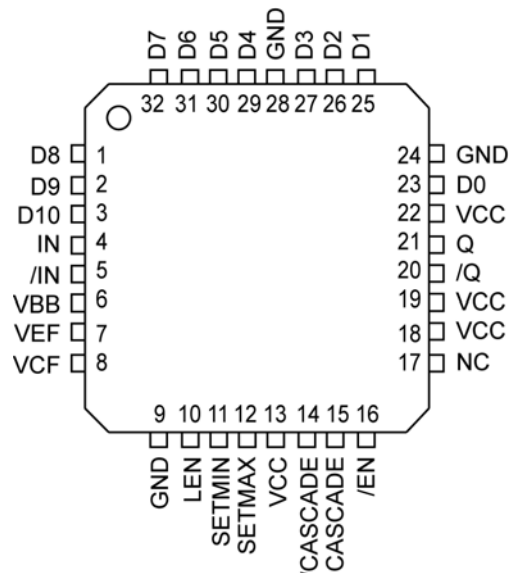

**32-Pin TQFP (T32-1)**

## Truth Tables

### Input/Output

Inputs		Outputs	
IN	/IN	OUT	/OUT
0	1	0	1
1	0	1	0

### Digital Control Latch

LEN	Latch Action
0	Pass Through D[10:0]
1	Latched

### Input Enable

/EN	Q, /Q
0	IN, /IN Delayed
1	Latched D[10:0]

### Functional Block Diagram

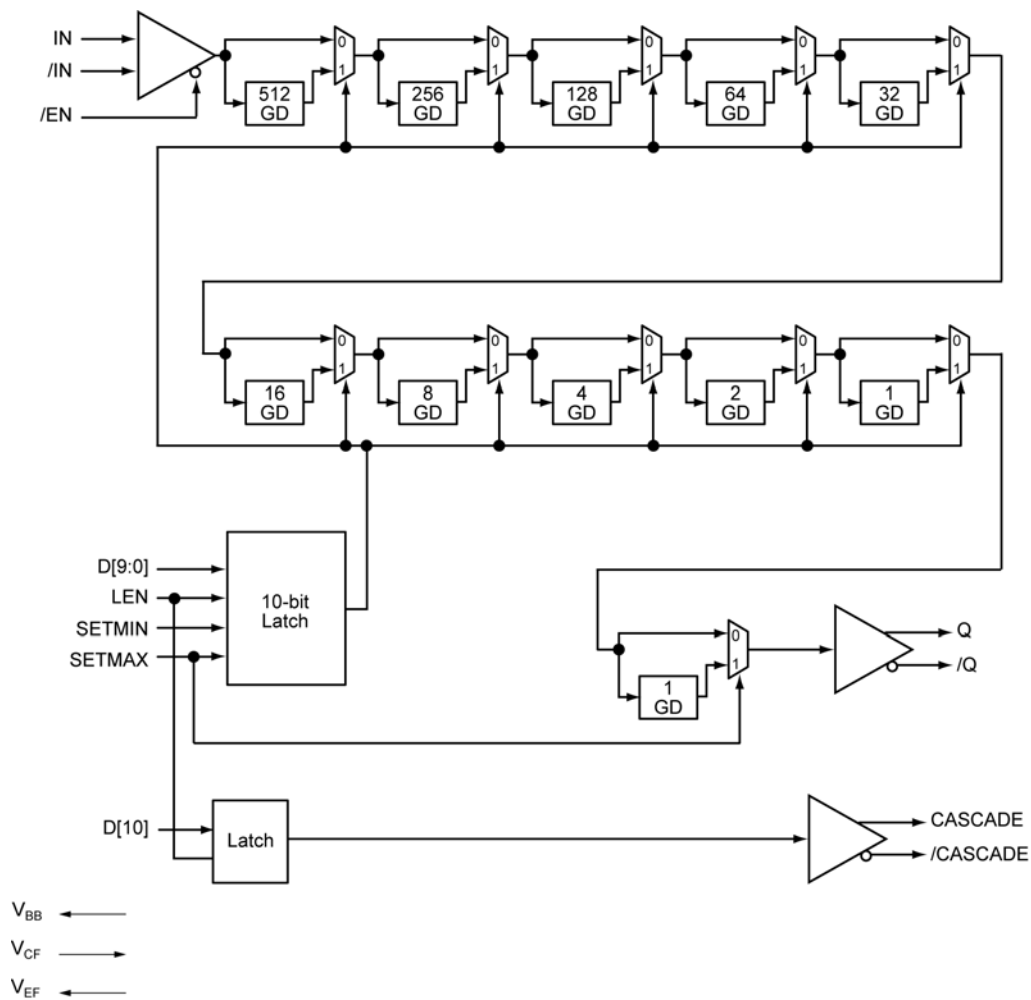

SY89295U Block Diagram

## Pin Description

Pin Number	Pin Name	Pin Function	
23, 25, 26, 27, 29, 30, 31, 32, 1, 2	D[9:0]	CMOS, ECL, or TTL Control Bits: These control signals adjust the delay from IN to Q. See “AC Electrical Characteristics” for delay values. In addition, see “Interface Applications” section which illustrates the proper interfacing techniques for different logic standards. D[9:0] contains pull-downs and defaults LOW when left floating. D0 (LSB), and D9 (MSB). See “Typical Operating Characteristics” for delay information.	
3	D10	CMOS, ECL, or TTL Control Bit: This bit is used to cascade devices for an extended delay range. In addition, it drives CASCADE, and /CASCADE. Further, D[10] contains a pull-down and defaults LOW when left floating.	
4, 5	IN, /IN	LVPECL/ECL Signal Input: Input signal to be delayed. IN contains a 75k $\Omega$ pull-down and will default to a logic LOW if left floating.	
6	VBB <sup>(1)</sup>	Reference Voltage Output: When using a single-ended input signal source to IN or /IN, connect the unused input of the differential pair to this pin. This pin can also be used to re-bias AC-coupled inputs to IN and /IN. When used, de-couple to V <sub>CC</sub> using a 0.01 $\mu$ F capacitor, otherwise leave floating if not used. Maximum sink/source is $\pm 0.5$ mA.	
7	VEF	Reference Voltage Output: Connect this pin to V <sub>CF</sub> when D[9:0], and D[10] is ECL..	
		<b>Logic Standard</b>	<b>V<sub>CF</sub> Connects to:</b>
		LVPECL	V <sub>EF</sub> , <sup>(1)</sup>
		CMOS	No Connect
		TTL	1.5V Source
8	VCF	Reference Voltage Input: The voltage driven on V <sub>CF</sub> sets the logic transition threshold for D[9:0], and D[10].	
9, 24, 28	GND, Exposed Pad <sup>(2)</sup>	Negative Supply: For MLF <sup>®</sup> package, exposed pad must be connected to a ground plane that is the same potential as the ground pin.	
10	LEN	ECL Control Input: When HIGH latches the D[9:0] and D[10] bits. When LOW, the D[9:0] and D[10] latches are transparent.	
11	SETMIN	ECL Control Input: When HIGH, D[9:0] registers are reset. When LOW, the delay is set by SETMAX or D[9:0] and D[10]. SETMIN contains a pull-down and defaults LOW when left floating.	
12	SETMAX	ECL Control Input: When SETMAX is set HIGH and SETMIN is set LOW, D[9:0] = 11111111. When SETMAX is LOW, the delay is set by SETMIN or D[9:0] and D[10]. SETMAX contains a pull-down and defaults LOW when left floating.	
13, 18, 19, 22	VCC	Positive Power Supply: Bypass with 0.1 $\mu$ F and 0.01 $\mu$ F low ESR capacitors.	
14, 15	/Cascade, Cascade	LVPECL Differential Output: The outputs are used when cascading two or more SY89295U to extend the delay range.	
16	/EN	LVPECL Single-Ended Control Input: When LOW, Q is delayed from IN. When HIGH, Q is a differential LOW. /EN contains a pull-down and defaults LOW when left floating.	
20, 21	/Q, Q	LVPECL Differential Output: Q is a delayed version of IN. Always terminate the output with 50 $\Omega$ to V <sub>CC</sub> – 2V. See “Output Interface Applications” section.	
17	NC	No Connect.	

### Notes:

1. Single-ended operation is only functional at 3.3V.
2. MLF<sup>®</sup> package only.

### Absolute Maximum Ratings<sup>(1)</sup>

Supply Voltage ( $V_{CC}$ )	-0.5V to +4.0V
Input Voltage ( $V_{IN}$ )	-0.5V to $V_{CC}$
LVPECL Output Current ( $I_{OUT}$ )	
Continuous	50mA
Surge	100mA
Lead Temperature (soldering, 20 sec.)	+260°C
Storage Temperature Range ( $T_S$ )	-65°C to +150°C

### Operating Ratings<sup>(2)</sup>

Supply Voltage ( $V_{CC}$ )	+2.375V to +3.6V
Ambient Temperature ( $T_A$ )	-40°C to +85°C
Package Thermal Resistance <sup>(3)</sup>	
MLF <sup>®</sup> ( $\theta_{JA}$ )	
Still-Air	35°C/W
MLF <sup>®</sup> ( $\psi_{JB}$ )	
Junction-to-Board	28°C/W
TQFP ( $\theta_{JA}$ )	
Still-Air	28°C/W
TQFP ( $\psi_{JB}$ )	
Junction-to-Board	20°C/W

### DC Electrical Characteristics<sup>(4)</sup>

$T_A = -40^\circ\text{C}$  to  $+85^\circ\text{C}$ , unless noted.

Symbol	Parameter	Condition	Min.	Typ.	Max.	Units
$V_{CC}$	Power Supply	$V_{CC} = 2.5\text{V}$	2.375	2.5	2.625	V
		$V_{CC} = 3.3\text{V}$	3	3.3	3.6	
$I_{EE}$	Power Supply Current	No load, max. $V_{CC}$			220	mA
$V_{IN}$	Input Voltage Swing (IN, /IN)	See Figure 1a.	150		1200	mV
$V_{DIFF\_IN}$	Differential Input Voltage Swing (IN, /IN)	See Figure 1b.	300		2400	mV
$V_{IHCMR}$	Input High Common Mode Range	IN, /IN	$V_{EE} + 1.2$		$V_{CC}$	V

$V_{CC} = 3.3\text{V}$ ,  $T_A = -40^\circ\text{C}$  to  $85^\circ\text{C}$ , unless otherwise stated.

Symbol	Parameter	Condition	Min.	Typ.	Max.	Units
$V_{IH}$	Input High Voltage (IN, /IN)		2.075		2.420	V
$V_{IL}$	Input Low High Voltage (IN, /IN)		1.355		1.675	V
$V_{BB}$	Output Voltage Reference		1.775	1.875	1.975	V
$V_{EF}$	Mode Connection		1.9	2.0	2.1	V
$V_{CF}$	Input Select Voltage		1.55	1.65	1.75	V

**Notes:**

1. Permanent device damage may occur if "Absolute Maximum Ratings" are exceeded. This is a stress rating only and functional operation is not implied at conditions other than those detailed in the operational sections of this data sheet. Exposure to "Absolute Maximum Rating" conditions for extended periods may affect device reliability.
2. The data sheet limits are not guaranteed if the device is operated beyond the operating ratings.
3. Thermal performance on MLF<sup>®</sup> packages assumes exposed pad is soldered (or equivalent) to the device most negative potential (GND).
4. The circuit is designed to meet the DC specifications shown in the table above after thermal equilibrium has been established. Input and output parameters vary 1:1 with  $V_{CC}$ , with the exception of  $V_{CF}$ .

## DC Electrical Characteristics<sup>(4)</sup> (Continued)

$V_{CC} = 2.5V$ ,  $T_A = -40^{\circ}C$  to  $85^{\circ}C$ , unless otherwise stated.

Symbol	Parameter	Condition	Min.	Typ.	Max.	Units
$V_{IH}$	Input High Voltage (IN, /IN)		1.275		1.62	V
$V_{IL}$	Input Low High Voltage (IN, /IN)		0.555		0.875	V
$V_{BB}$	Output Voltage Reference		1.175	1.075	0.975	V
$V_{EF}$	Mode Connection		1.10	1.20	1.30	V
$V_{CF}$	Input Select Voltage		1.15	1.25	1.35	V

## LVPECL Outputs DC Electrical Characteristics<sup>(4)</sup>

$V_{CC} = 3.3V$ ;  $R_{LOAD} = 50\Omega$  to  $V_{CC}-2V$ ;  $T_A = -40^{\circ}C$  to  $+85^{\circ}C$ , unless noted.

Symbol	Parameter	Condition	Min.	Typ.	Max.	Units
$V_{OH}$	Output HIGH Voltage (Q, /Q)		2.155	2.280	2.405	V
$V_{OL}$	Output LOW Voltage (Q, /Q)		1.355	1.480	1.605	V
$V_{OUT}$	Output Voltage Swing (Q, /Q)	See Figure 1a.	550	800		mV
$V_{DIFF\_OUT}$	Differential Output Voltage Swing (Q, /Q)	See Figure 1b.	1.1	1.6		V

## LVPECL Outputs DC Electrical Characteristics<sup>(5)</sup>

$V_{CC} = 2.5V$ ;  $R_{LOAD} = 50\Omega$  to  $V_{CC}-2V$ ;  $T_A = -40^{\circ}C$  to  $+85^{\circ}C$ , unless noted.

Symbol	Parameter	Condition	Min.	Typ.	Max.	Units
$V_{CC}$	Output HIGH Voltage (Q, /Q)		1.355	1.480	1.605	V
$I_{EE}$	Output LOW Voltage (Q, /Q)		0.555	0.68	0.805	V
$V_{IN}$	Output Voltage Swing (Q, /Q)	See Figure 1a.	550	800		mV
$V_{DIFF\_OUT}$	Differential Output Voltage Swing (Q, /Q)	See Figure 1b.	1.1	1.6		V

## LVTTL/CMOS DC Electrical Characteristics<sup>(6)</sup>

$V_{CC} = 2.5V \pm 5\%$  or  $3.3V \pm 10\%$ ;  $T_A = -40^{\circ}C$  to  $+85^{\circ}C$ , unless noted.

Symbol	Parameter	Condition	Min	Typ	Max	Units
$V_{IH}$	Input HIGH Voltage		2.0			V
$V_{IL}$	Input LOW Voltage				0.8	V
$I_{IH}$	Input HIGH Current				40	$\mu A$
$I_{IL}$	Input LOW Current		-300			$\mu A$

### Notes:

- The circuit is designed to meet the DC specifications shown in the table above after thermal equilibrium has been established.  $V_{OH}$  and  $V_{OL}$  parameters vary 1:1 with  $V_{CC}$ .
- The circuit is designed to meet the DC specifications shown in the table above after thermal equilibrium has been established.

## AC Electrical Characteristics<sup>(7)</sup>

T<sub>A</sub> = -40°C to +85°C, unless noted.

Symbol	Parameter	Condition	Min.	Typ.	Max.	Units
f <sub>MAX</sub>	Maximum Operating Frequency	Clock V <sub>OUT</sub> ≥ 400mV	1.5			GHz
t <sub>pd</sub>	Propagation Delay IN to Q; D[0-10]=0 IN to Q; D[0-10]=1023 /EN to Q: D[0-10]=0 D10 to CASCADE		3200 11500 3400 350		4200 14800 4400 670	ps
t <sub>RANGE</sub>	Programmable Range t <sub>pd</sub> (max.) – t <sub>pd</sub> (min)		8300			ps
t <sub>SKEW</sub>	Duty Cycle Skew t <sub>PHL</sub> – t <sub>PLH</sub>	<b>Note 8</b>			25	ps
Δt	Step Delay D0 High D1 High D2 High D3 High D4 High D5 High D6 High D7 High D8 High D9 High D0-D9 High			10 15 35 70 145 290 575 1150 2300 4610 9220		ps
INL	Integral Non-Linearity	<b>Note 9</b>		±10		ps
t <sub>S</sub>	Setup Time D to LEN D to IN /EN to IN	<b>Note 10</b> <b>Note 11</b>	200 350 300			ps
t <sub>H</sub>	Hold Time LEN to D IN to /EN	<b>Note 12</b>	200 400			ps

### Notes:

- High-frequency AC electricals are guaranteed by design and characterization.
- Duty cycle skew guaranteed only for differential operation measured from the cross point of the input to the crosspoint of the output.
- INL (Integral Non-Linearity) is defined from its corresponding point on the ideal delay versus D[9:0] curve as the deviation from its ideal delay. The maximum difference is the INL. Theoretical Ideal Linearity (TIL) = (measured maximum delay – measured minimum delay) ÷ 1024. INL = measured delay – measured minimum delay + (step number ∞ TIL).
- This setup time defines the amount of time prior to the input signal. The delay tap of the device must be set.
- This setup time defines the amount of the time that /EN must be asserted prior to the next transition of IN, /IN to prevent an output response greater than ±75mV to the IN, /IN transition.
- Hold time is the minimum time that /EN must remain asserted after a negative going IN or a positive going /IN to prevent an output response greater than ±75mV to the IN, /IN transition.



**AC Electrical Characteristics<sup>(7)</sup>**T<sub>A</sub> = -40°C to +85°C, unless noted.

Symbol	Parameter	Condition	Min.	Typ.	Max.	Units
t <sub>R</sub>	Release Time /EN to IN SETMAX to LEN SETMIN to LEN		500 500 450			ps
t <sub>JITTER</sub>	Cycle-to-Cycle Jitter Total Jitter Random Jitter	<b>Note 13</b> <b>Note 14</b> <b>Note 15</b>			2 10 1	pSRMS pSPP pSRMS
t <sub>r</sub> , t <sub>f</sub>	Output Rise/Fall Time	20% to 80% (Q) 20% to 80% (Cascade)	50 90	85	160 300	ps
	Duty Cycle		45		55	%

**Notes:**

13. Cycle-to-cycle jitter definition: The variation of periods between adjacent cycles over a random sample of adjacent cycle pairs.  
T<sub>jitter\_cc</sub> = T<sub>n</sub> - T<sub>n+1</sub>, where T is the time between rising edges of the output signal.
14. Total jitter definition: With an ideal clock input, no more than one output edge in 10<sup>12</sup> output edges will deviate by more than the specified peak-to-peak jitter value.
15. Random jitter definition: Jitter that is characterized by a Gaussian distribution, unbounded and is quantified by its standard deviation and mean. Random jitter is measured with a K28.7 comma defect pattern, measured at 1.5Gbps.

## Typical Operating Characteristics

$V_{CC} = 3.3V$ ,  $GND = 0$ ,  $D_{IN} = 100mV$ ,  $T_A = 25^\circ C$ , unless otherwise stated.

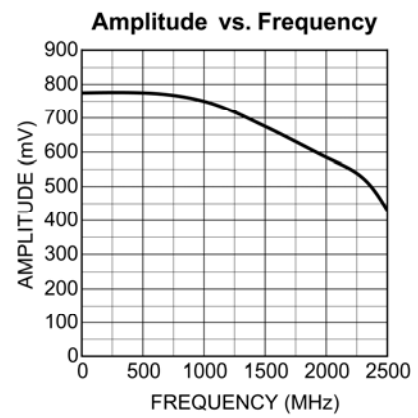
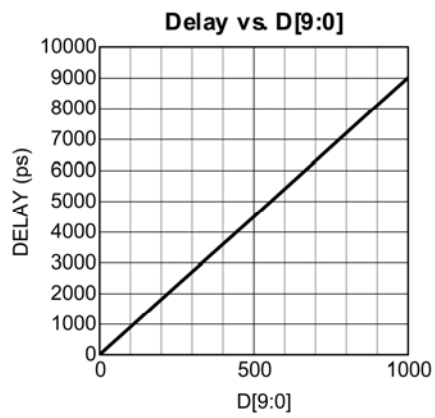

## Timing Diagrams

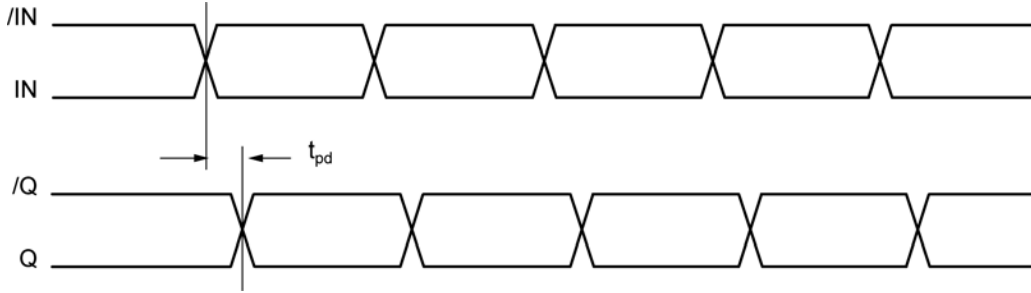

## Single-Ended and Differential Swings

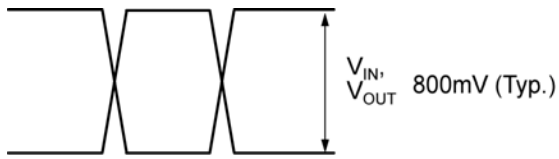

Figure 1a. Single-Ended Voltage Swing

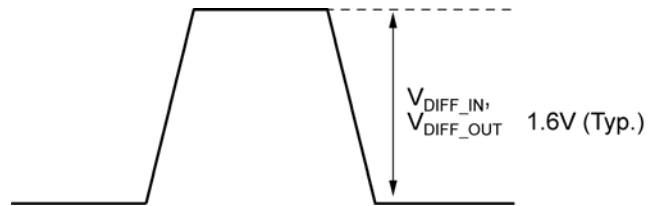

Figure 1b. Differential Voltage Swing

## Input and Output Stages

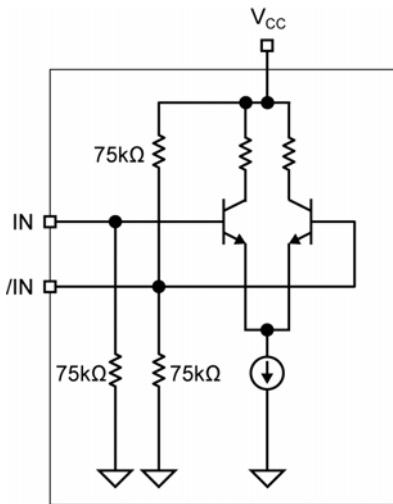

Figure 2a. Differential Input Stage

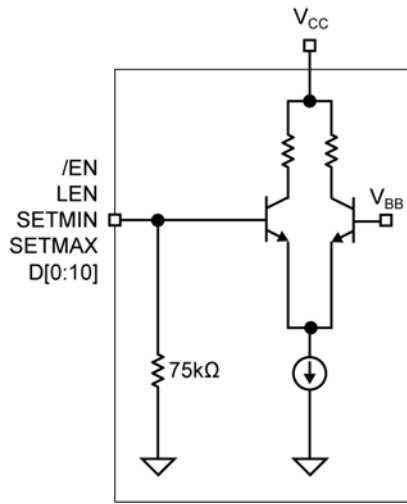

Figure 2b. Single-Ended Input Stage

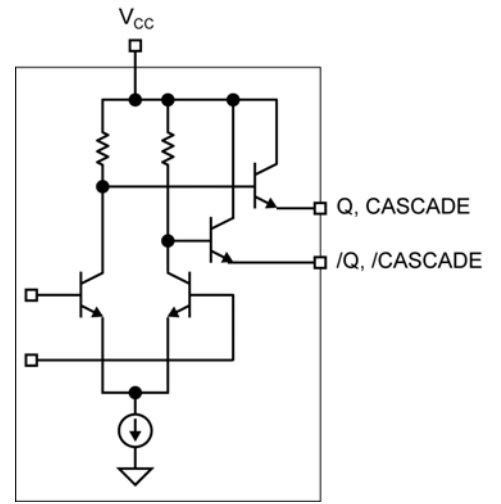

Figure 3. LVPECL Output Stage

## Output Interface Applications

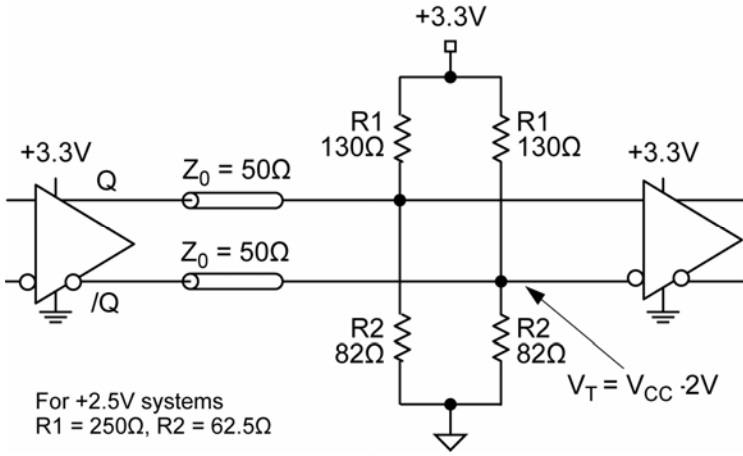

Figure 4. Parallel Termination

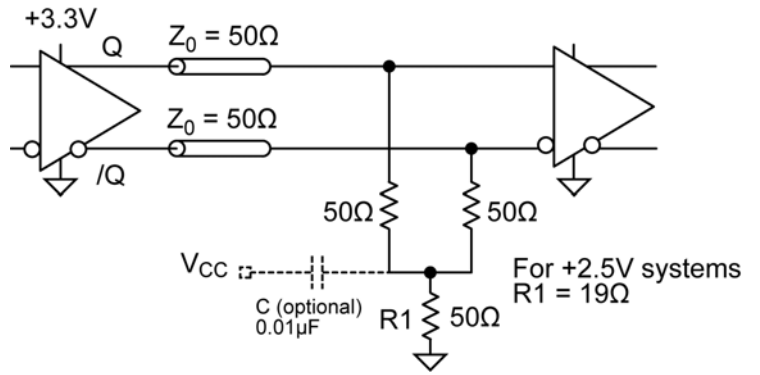

Figure 5. Y-Termination

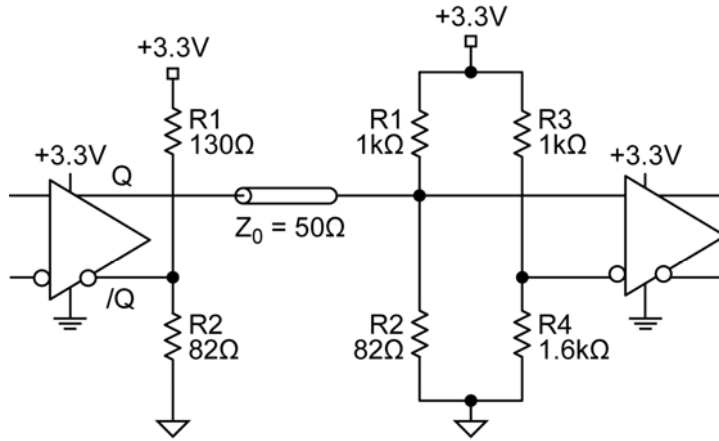

Figure 6. Terminating Unused I/O

## Applications Information

For best performance, use good high-frequency layout techniques, filter  $V_{CC}$  supplies, and keep ground connections short. Use multiple vias where possible. Also, use controlled impedance transmission lines to interface with the SY89295U data inputs and outputs.

### $V_{BB}$ Reference

The  $V_{BB}$  pin is an internally generated reference and is available for use only by the SY89295U. When unused, this pin should be left unconnected. Two common uses for  $V_{BB}$  are to handle a single-ended PECL input, and to re-bias inputs for AC-coupling applications.

If IN and /IN are driven by a single-ended output,  $V_{BB}$  is used to bias the unused input. Please refer to Figure 10. The PECL signal driving the SY89295U may optionally be inverted in this case.

When the signal is AC-coupled,  $V_{BB}$  is used, as shown in Figure 13, to re-bias IN and /IN. This ensures that SY89295U inputs are within acceptable common mode range.

In all cases,  $V_{BB}$  current sinking or sourcing must be limited to 0.5mA or less.

### Setting D Input Logic Thresholds

In all designs where the SY89295U GND supply is at zero volts, the D inputs can accommodate CMOS and TTL level signals, as well as PECL or LVPECL. Figures 11, 12 and 14 show how to connect  $V_{CF}$  and  $V_{EF}$  for all possible cases.

### Cascading

Two or more SY89295U may be cascaded in order to extend the range of delays permitted. Each additional SY89295U adds about 3.2ns to the minimum delay and adds another 10240ps to the delay range.

Internal cascade circuitry has been included in the SY89295U. Using this internal circuitry, the SY89295U may be cascaded without any external gating.

Examples of cascading 2, 3, or 4 SY89295U appear in Figures 7, 8, and 9.

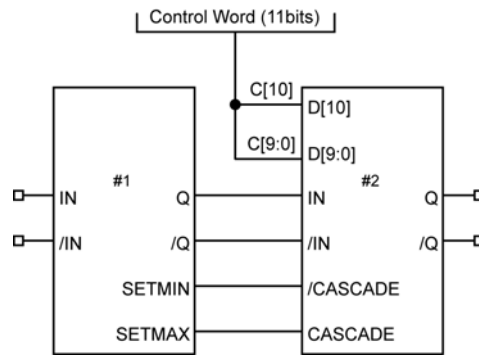

Figure 7. Cascading Two SY89295U

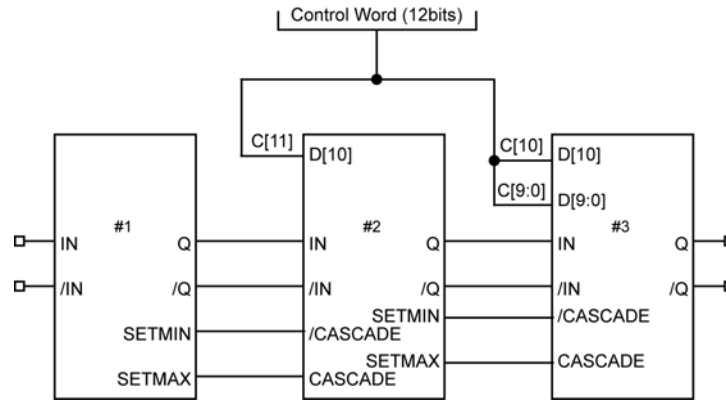

Figure 8. Cascading Three SY89295U

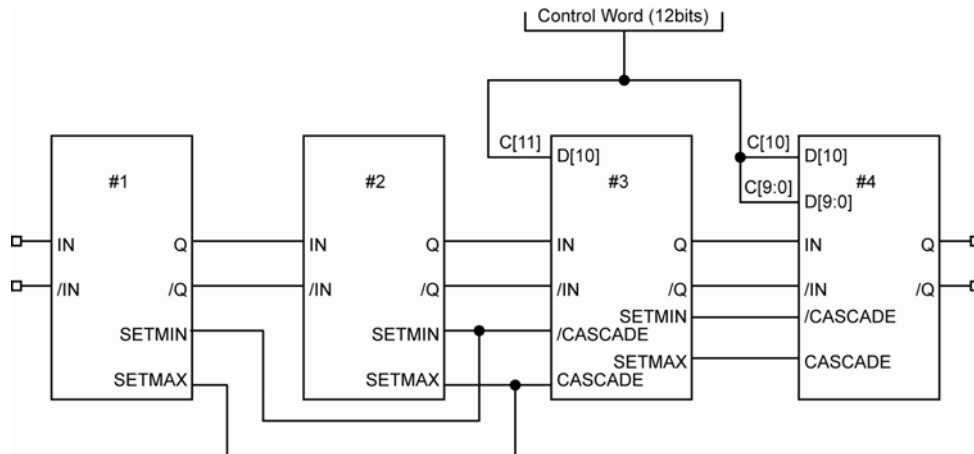
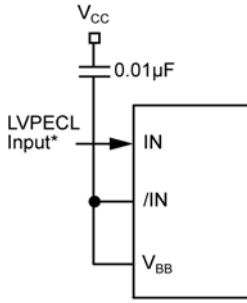

Figure 8. Cascading Four SY89295U

## Interface Applications



\* 3.3V single-ended only, 2.5V, single-ended is not functional.

**Figure 10. Interfacing to a Single-Ended LVPECL Signal**

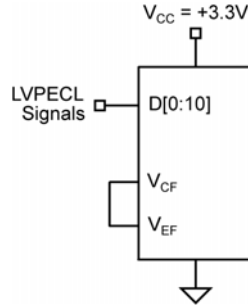

**Figure 11.  $V_{CF}/V_{EF}$  Biasing for LVPECL Control (D) Input**

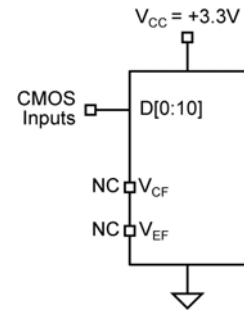

**Figure 12.  $V_{CF}/V_{EF}$  Biasing for CMOS (D) Input**

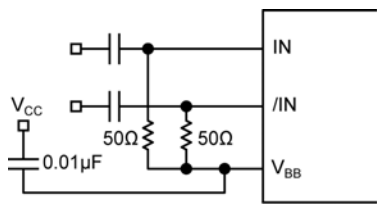

**Figure 13. Re-Biasing an AC-Coupled Signal**

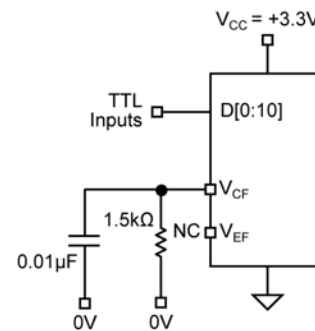
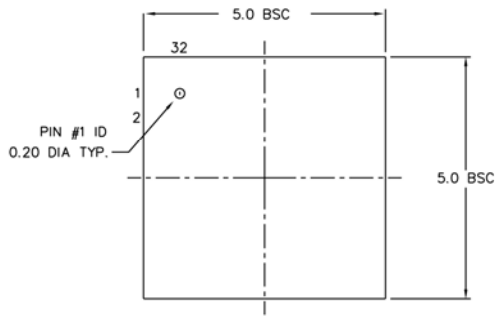

**Figure 14.  $V_{CF}/V_{EF}$  Biasing for LVTTTL Control (D) Input**

## Related Product and Support Documentation

Part Number	Function	Datasheet Link
SY89295U	2.5/3.3V 1.5GHz Precision LVPECL Programmable Delay	<a href="http://www.micrel.com/product-info/products/sy89295u.shtml">www.micrel.com/product-info/products/sy89295u.shtml</a>
SY89296U	2.5/3.3V 1.5GHz Precision LVPECL Programmable Delay with Fine Tune Control	<a href="http://www.micrel.com/product-info/products/sy89296u.shtml">www.micrel.com/product-info/products/sy89296u.shtml</a>
	16-MLF Manufacturing Guidelines Exposed Pad Application Note	<a href="http://www.amkor.com/products/notes_papers/MLF_appnote_0902.pdf">www.amkor.com/products/notes_papers/MLF_appnote_0902.pdf</a>
	HBW Solutions	<a href="http://www.micrel.com/product-info/as/solutions.shtml">http://www.micrel.com/product-info/as/solutions.shtml</a>

# Package Information



TOP VIEW

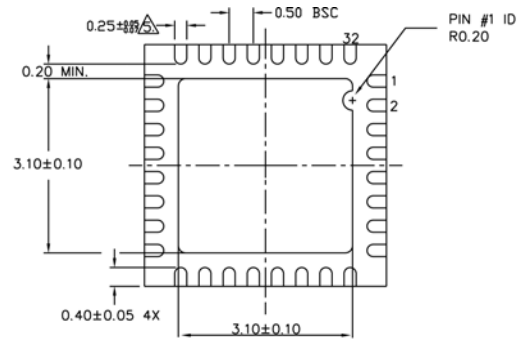

BOTTOM VIEW



SIDE VIEW

- NOTE:
1. ALL DIMENSIONS ARE IN MILLIMETERS.
  2. MAX. PACKAGE WARPAGE IS 0.05 mm.
  3. MAXIMUM ALLOWABLE BURRS IS 0.076 mm IN ALL DIRECTIONS.
  4. PIN #1 ID ON TOP WILL BE LASER/INK MARKED.
- ⚠ DIMENSION APPLIES TO METALIZED TERMINAL AND IS MEASURED BETWEEN 0.20 AND 0.25 mm FROM TERMINAL TIP.
- ⚠ APPLIED ONLY FOR TERMINALS.
- ⚠ APPLIED FOR EXPOSED PAD AND TERMINALS.

MLF55Q-32LD-PD-2-B

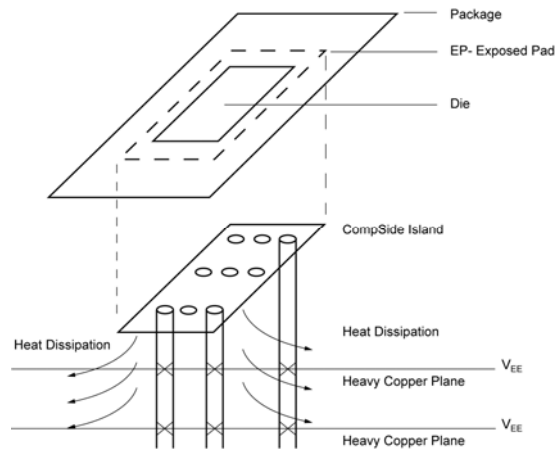

### PCB Thermal Consideration for 32-Pin MLF® Package (Always solder, or equivalent, the exposed pad to the PCB)

**Package Notes:**

1. Package meets Level 2 qualifications
2. All parts are dry-packed before shipment.
3. Exposed pads must be soldered to a ground for proper thermal management.

### 32-Pin MLF® (MLF-32)



**Package Information (Continued)**

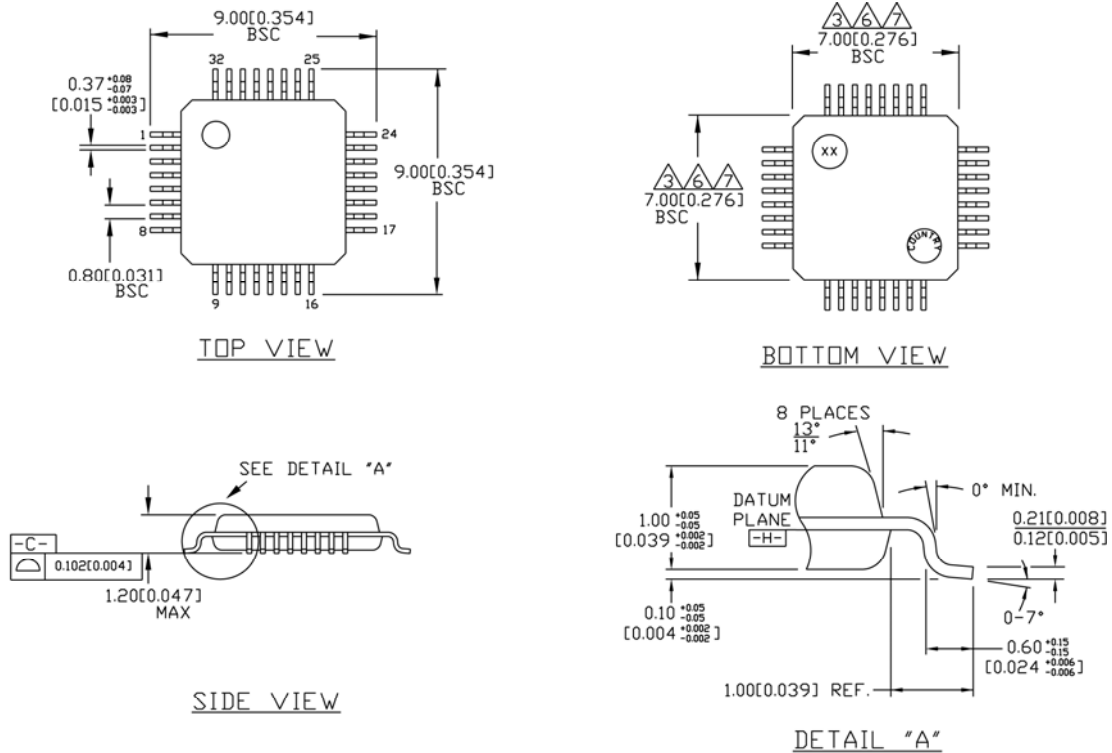

**NOTES:**

1. DIMENSIONS ARE IN MM[INCHES].
2. CONTROLLING DIMENSION: MM.
3. DIMENSION DOES NOT INCLUDE MOLD FLASH OR PROTRUSIONS, EITHER OF WHICH SHALL NOT EXCEED 0.254 [0.010].
4. LEAD DIMENSION DOES NOT INCLUDE DAMBAR PROTRUSION.
5. MAXIMUM AND MINIMUM SPECIFICATIONS ARE INDICATED AS FOLLOWS: MAX/MIN.
6. THESE DIMENSIONS TO BE DETERMINED AT DATUM PLANE [H].
7. PACKAGE TOP DIMENSIONS ARE SMALLER THAN BOTTOM DIMENSIONS AND TOP OF PACKAGE WILL NOT OVERHANG BOTTOM OF PACKAGE.

**32-Pin TQFP (T32-1)**

**MICREL, INC. 2180 FORTUNE DRIVE SAN JOSE, CA 95131 USA**  
 TEL +1 (408) 944-0800 FAX +1 (408) 474-1000 WEB <http://www.micrel.com>

Micrel makes no representations or warranties with respect to the accuracy or completeness of the information furnished in this data sheet. This information is not intended as a warranty and Micrel does not assume responsibility for its use. Micrel reserves the right to change circuitry, specifications and descriptions at any time without notice. No license, whether express, implied, arising by estoppel or otherwise, to any intellectual property rights is granted by this document. Except as provided in Micrel's terms and conditions of sale for such products, Micrel assumes no liability whatsoever, and Micrel disclaims any express or implied warranty relating to the sale and/or use of Micrel products including liability or warranties relating to fitness for a particular purpose, merchantability, or infringement of any patent, copyright or other intellectual property right.

Micrel Products are not designed or authorized for use as components in life support appliances, devices or systems where malfunction of a product can reasonably be expected to result in personal injury. Life support devices or systems are devices or systems that (a) are intended for surgical implant into the body or (b) support or sustain life, and whose failure to perform can be reasonably expected to result in a significant injury to the user. A Purchaser's use or sale of Micrel Products for use in life support appliances, devices or systems is a Purchaser's own risk and Purchaser agrees to fully indemnify Micrel for any damages resulting from such use or sale.

© 2006 Micrel, Incorporated.