

THIS DRAWING IS UNPUBLISHED. RELEASED FOR PUBLICATION  
 © COPYRIGHT BY TYCO ELECTRONICS CORPORATION. ALL INTERNATIONAL RIGHTS RESERVED.

LOC	DIST	REVISIONS					
		P	LTR	DESCRIPTION	DATE	DWN	APVD
AJ	00		A	REVISED	12/08/93	-	APD
			B	REVISED PER ECO-08-030676	02-26-09	AEG	JKO

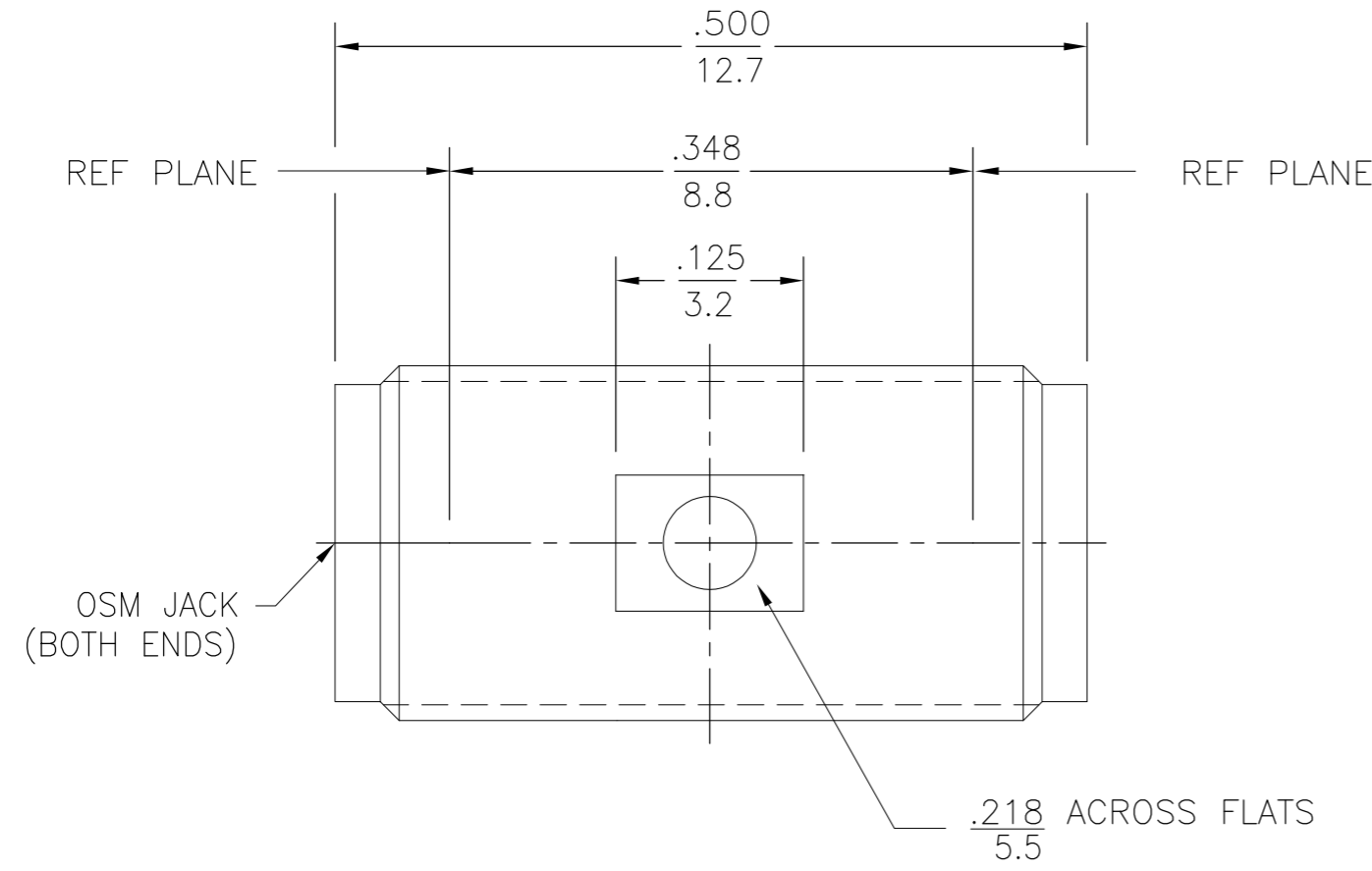

- ① BRASS
- ② STAINLESS STEEL
- ③ BERYLLIUM COPPER
- ④ PTFE
- ⑤ GOLD PLATE
- ⑥ PASSIVATED
- ⑦ SILICONE RUBBER
- ⑧ NICKEL PLATE

ELECTRICAL	MECHANICAL	ENVIRONMENTAL
Nominal Impedance (Ohms) <u>50</u>	Interface Dimensions MIL-STD-348A, Fig. 310.2	TEMPERATURE RATING <u>-65°C TO 165°C</u>
Frequency Range (GHz) DC to 18	Recommended Mating Torque <u>7 - 10 in-lbs</u>	Vibration MIL-STD-202, Method 204, Condition D
Volt Rating (VRMS MAX) @ Sea Level <u>335</u>	Mating Characteristics: Insertion (MAX Lbs) <u>3.0</u>	Shock MIL-STD-202, Method 213, Condition I
VSWR <u>1.05 + .005 f(GHz)</u>	Withdrawal (MIN Oz) <u>1.0</u>	Thermal Shock MIL-STD-202, Method 107, Condition C,
Insertion Loss (dB MAX) <u>.06 √f(GHz)</u>	Force to Engage and Disengage (In/Lbs MAX) <u>2.0</u>	Moisture Resistance MIL-STD-202, Method 106, Except Vibration
RF Leakage (dB MIN) <u>-[60-f(GHz)]</u>	Center Contact Captivation Axial (Lbs) <u>6.0</u>	Shall Be Omitted
Dielectric Withstanding Voltage (VRMS MIN) @ Sea Level <u>1500</u>	Radial (In/Oz) <u>N/A</u>	Corrosion - MIL-STD-202, Method 101, Condition B, 5% salt spray
Contact Resistance (Milliohms MAX) Center Contact <u>4.0</u>	Cable Retention Axial Force (Lbs) <u>N/A</u>	
Outer Contact <u>2.0</u>	Torque (In/Oz) <u>N/A</u>	
Cable to Housing <u>N/A</u>	Weight (Grams) <u>2.0</u>	
RF High Potential @ Sea Level (VRMS MIN @ 5 MHz) <u>670</u>		
I.R.(Megohms MIN) <u>5,000</u>		

.XXX = in  
 XX.X = mm

THIS DRAWING IS A CONTROLLED DOCUMENT.

DIMENSIONS: INCHES	TOLERANCES UNLESS OTHERWISE SPECIFIED:
	0 PLC ± -
	1 PLC ± -
	2 PLC ± -
	3 PLC ± .005
	4 PLC ± - ± 1'
MATERIAL	FINISH
-	-

DWN	BWC	12/27/67
CHK	-	12/21/67
APVD	D.NANIA	12/21/67
PRODUCT SPEC	-	-
APPLICATION SPEC	-	-
WEIGHT	-	-
CUSTOMER DRAWING		

③⑤	④	①⑧	1053489-2
③⑤	④	②⑥	1053489-1
CONTACT	DIELECTRIC	HOUSING	TE PN
Tyco Electronics Corporation Harrisburg, PA 17105-3608			
NAME: OSM JACK TO JACK ADAPTER			
SIZE	CAGE CODE	DRAWING NO	RESTRICTED TO
A3	00779	C-1053489	-
SCALE 8:1		SHEET 1 OF 1	REV B